

**COJINETES, BUJES Y
ARANDELAS PARA MOTOR**



**CATÁLOGO DE APLICACIONES Y
REFERENCIAS TÉCNICAS 2008-2009**

CONTENIDO

	PAG.
DESCRIPCIÓN DE COJINETE	2
AUDI	6
CHRYSLER - DODGE - JEEP - PLYMOUTH	8
FORD - LINCOLN - MERCURY	42
GM CHEVROLET - BUICK - OLDSMOBILE - PONTIAC	84
HONDA	132
HYUNDAI	136
ISUZU	138
MAZDA	142
MITSUBISHI	148
NISSAN	156
RENAULT	174
SUZUKI	182
TOYOTA	184
VAM (RAMBLER)	192
VOLKSWAGEN	198
NÚMERO BIELA	211
NÚMERO BANCADA	233
NÚMERO BUJE DE ÁRBOL	257
NÚMERO ARANDELAS	269
INTERCAMBIOS CLEMEX A MORESA	273
INTERCAMBIOS FEDERAL MOGUL A MORESA	276
INTERCAMBIOS DURABOND A MORESA	279
DAÑOS EN COJINETES	281

COJINETE

MORESA!

EL COJINETE

Es un elemento conformado por dos o más materiales (capas de material antifricción), el cual soporta cargas y velocidades; protege y permite el giro libre y silencioso del cigüeñal ó árbol de levas, además es una pieza reemplazable que compensa el rectificado en estos componentes.

COJINETES PARA BIELA Y BANCADA

Moresa ofrece una línea completa de Cojinetes de Biela y Bancada (Metales), bajo requerimientos de Equipo Original, utilizando las últimas tecnologías metalúrgicas para la formulación de sus aleaciones de aluminio (Según SAE J460).

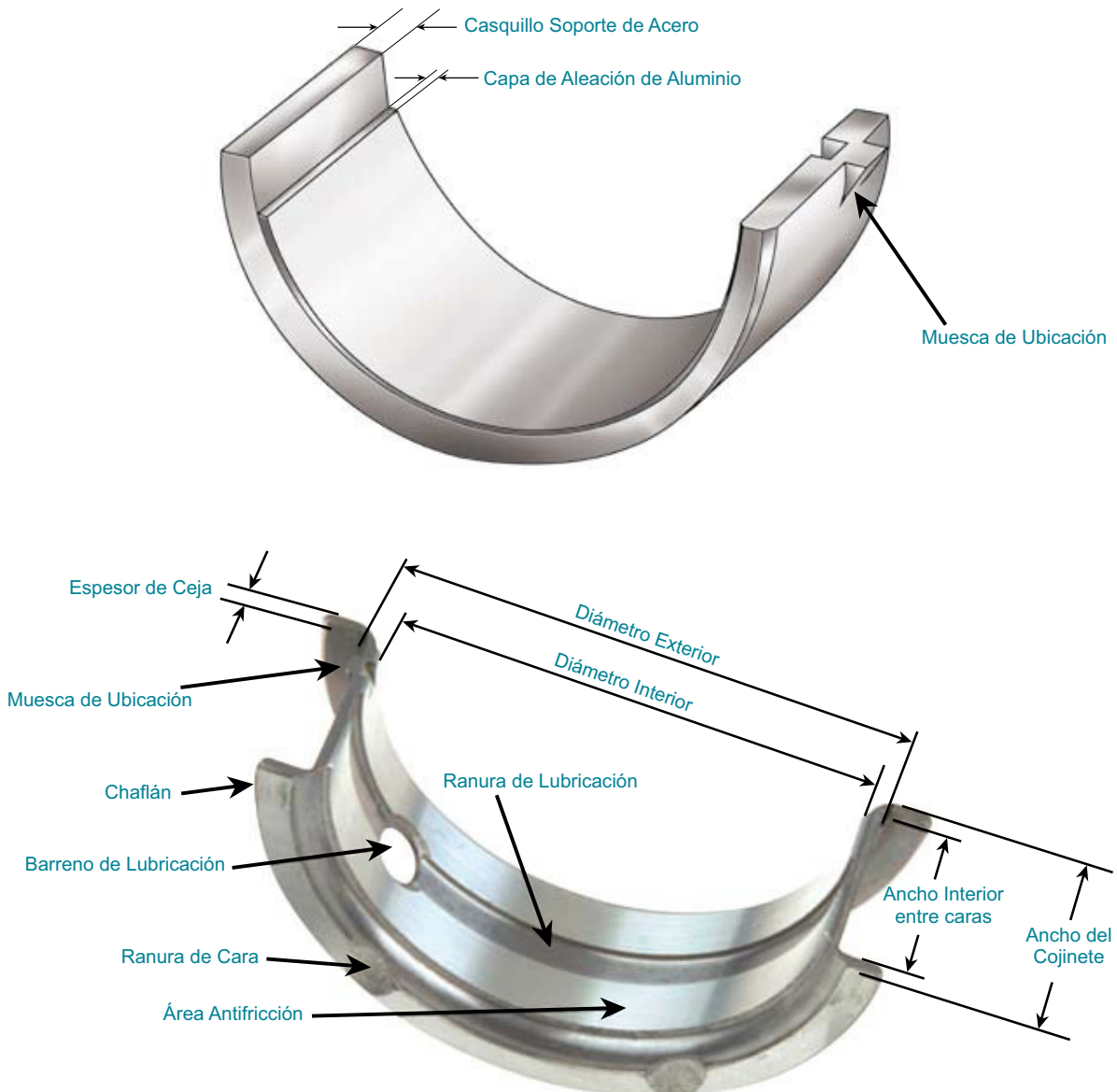

Los cojinetes por diseño cuentan con un diseño de tipo excéntrico lo que significa, que el espesor va disminuyendo desde el centro hacia sus extremos, esto ayudará al efecto de fijación de la pieza, y permitirá que la capa de aceite se forme bajo el área de carga.

Cuando realice las mediciones del cojinete, se deberá de hacer en el centro de la pieza, ya que al realizar la medición en alguna otra parte del cojinete se incurrirá en un error.

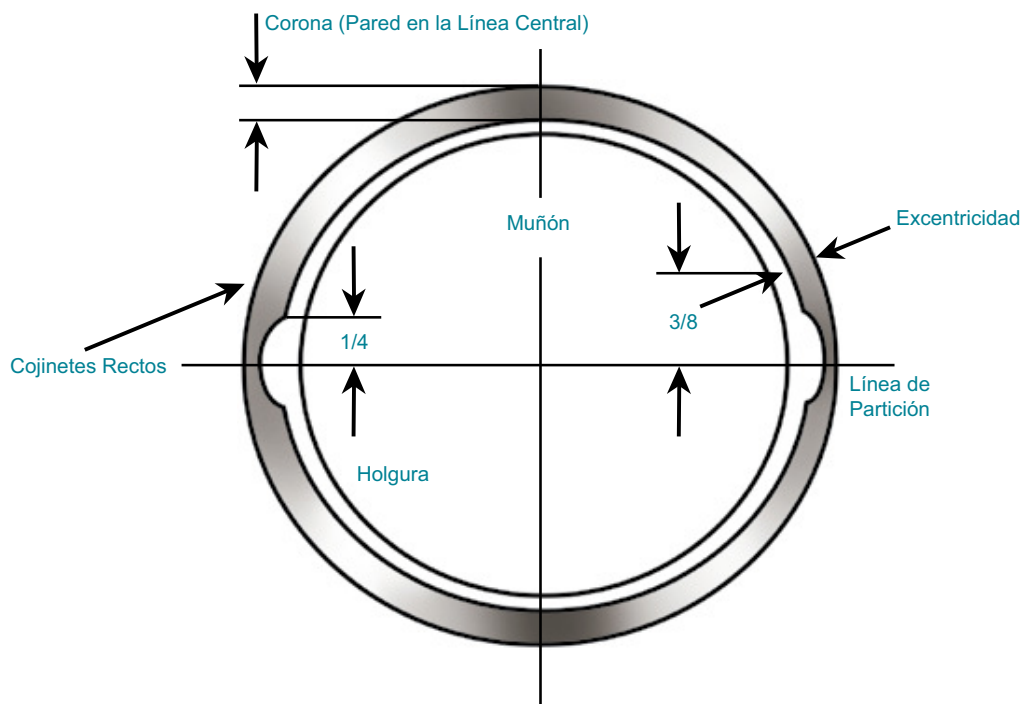

BUJES

Los Bujes Moresa ofrecen un perfecto ajuste al ser instalados en su alojamiento, brindan mayor capacidad de amoldamiento en su área de trabajo y protegen los muñones del árbol de levas ya que están especialmente diseñados para el mercado de repuesto, por las características de sus materiales y su fabricación de una sola pieza, brindan los siguientes beneficios:

- Ajuste suave y preciso
- Seguridad y rapidez en su instalación
- Evita pérdidas de presión de aceite
- No se abre ni deforma, haciendo más sencilla su instalación

COJINETE

MORESA!

Producidos bajo las más estrictas normas que requiere el mercado automotriz de equipo original, los bujes Moresa son rectificados en su diámetro exterior e interior por medio de un maquinado concéntrico, lo que le brinda una superficie perfectamente uniforme a lo largo de su circunferencia, ofreciendo una mayor área de contacto, tanto en el alojamiento como en la superficie de trabajo.

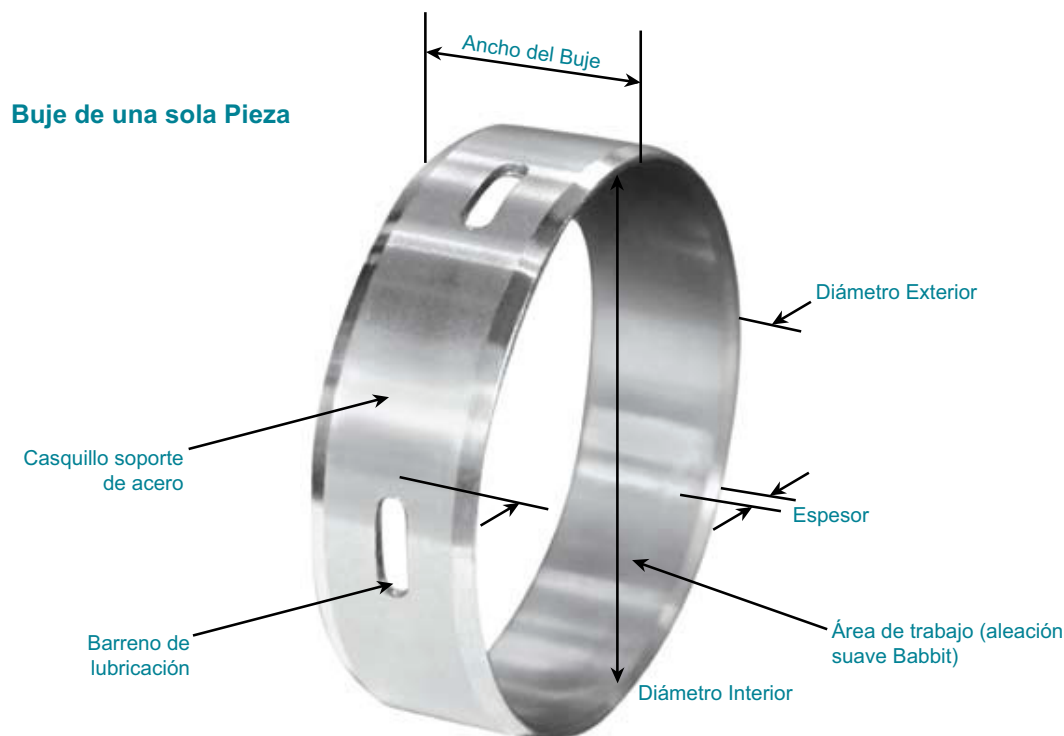

IMPORTANCIA DE UN TORQUE (APRIETE) ADECUADO

Para obtener el claro de lubricación adecuado, necesitamos aplicar el torque indicado por el fabricante.

Actualmente diversas especificaciones contienen fracciones de giro ó ángulo en grados, que se debe aplicar al apriete final.



Torquímetro



Angulómetro

CLARO DE LUBRICACION

Verifique el claro de lubricación con "Platigage".

El plastigage es una fibra compresible calibrada la cual nos indica el claro de lubricación y la uniformidad de asentamiento del muñón sobre el cojinete.

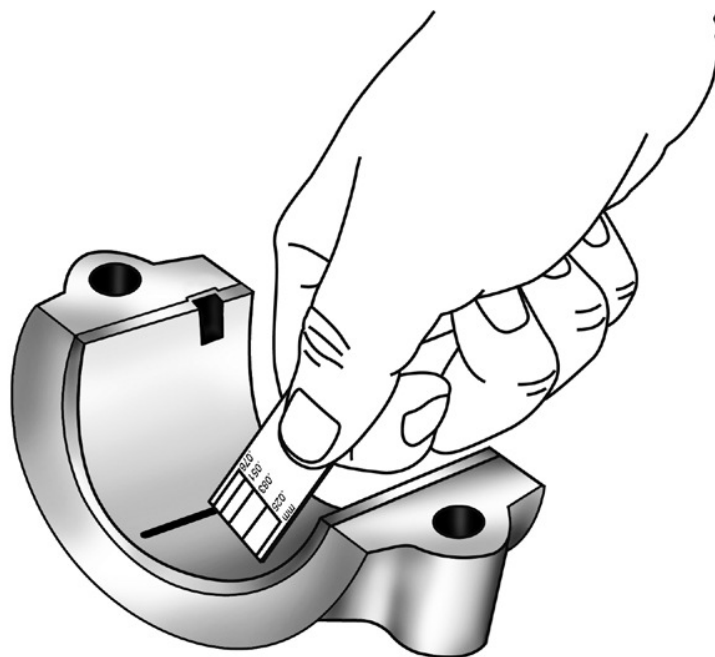
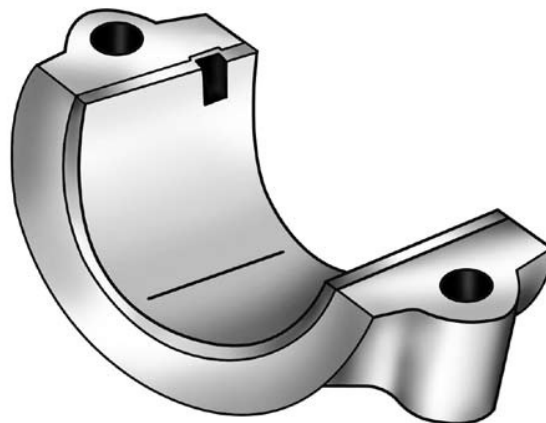



AUDI

MORESA

4 CILINDROS / 4 CYLINDER

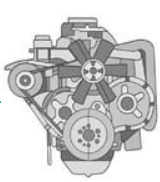
MOTOR / ENGINE	AÑO / YEAR	LINEA / LINE
1500 (1.5L)	1972-	1
1588 cc (1.6L)	1972-	1
1600 (1.6L) ABB,ABM,ADA,ADP- AEH,DT,JU,PP,RN	1985 -	1

CIL.	AÑO	MOTOR / APLICACIÓN		Diámetro del Cilindro Nominal Bore		Carrera Stroke	COJINETE, BUJE O ARANDELA	No. de Parte	Ubicación Location
				mm Pulgadas	mm Pulgadas				
CYL.	YEAR	ENGINE / APPLICATION					BEARING, BUSHING OR THURST WASHER	Part Number	
L4	1972-	1500 (1.5L) (1470 cc) Audi 80		76.50 3.012	80.00 3.149	COJINETE DE BIELA	4B1017 STD 010 020 030 040 050 060	1 2 3 4 5	TODOS
	1972-	1588 cc (1.6L) (1600) Audi 80/100		79.50 3.130	80.00 3.150				
	1985 -	1600 (1.6L) ABB,ABM,ADA,ADP- AEH,DT,JU,PP,RN (1595 cc) Audi 80, A3, A4, A4 Avant		81.00 3.189	77.40 3.047	COJINETE DE BANCADA	5C1157 STD 010 020 030	1-2-4-5 (A, B) 3 (C, D)	
						BUJE DE ARBOL	MO1726M STD		1 2
L4	1982-	1800 (1.8L) ADR/AEB/AGN/ AGU- DR/DS/DZ - JN/JV/JW/ - NE/NP/PH/PM/PV - RS/RU/SH/4B (1781 cc) A4,A4 Quattro/Avant/Cabrio Turb, Audi 80/100, A3/A3 Turbo		81.00 3.189	86.40 3.402	COJINETE DE BIELA	4B1426 STD 010 020 030 040	TODOS	
	1986-	2000 (2.0L) AAD,AAE,ABK,ABT- ADW,3A,6A (1984 cc) Audi 80/80E Quattro, Audi Avant/Cabrio, A6 Quattro		82.50 3.248	92.80 3.654	COJINETE DE BANCADA	5C1157 STD 010 020 030	1-2-4-5 (A, B) 3 (C, D)	

Línea Line

1

2

6

4 CILINDROS / 4 CYLINDER

MOTOR / ENGINE	AÑO / YEAR	LINEA / LINE
1800 (1.8L) ADR/AEB/AGN/AGU- DR/DS/DZ -	1982-	2
JN/JV/JW/ - NE/NP/PH/PM/PV - RS/RU/SH/4B		
2000 (1.8L) AAD,AAE,ABK,ABT- ADW,3A,6A	1986-	2

Diámetro Estándar del Muñón Standard Shaft Diameter	Diámetro Total del Alojamiento Housing Bore	Ancho del Cojinete Width Bearing	Espesor Máximo de Pared Max Wall Thickness	Claro de Lubricación Oil Clearance	Torque Torque	Imagen del Cojinete / Arandela Image of the Bearing and Thrust Washer
mm Pulgadas	mm Pulgadas	mm Pulgadas	mm Pulgadas	mm Pulgadas	N.m Lbs.Ft	
45.938/45.959 1.808/1.809	48.999/49.014 1.929/1.930	19.00 0.748	1.506 0.0593	0.0406/0.1016 0.0016/0.0040	45 N.m 33 Lbs.Ft	 8 Piezas
53.957/53.978 2.124/2.125	58.999/59.017 2.323/2.324	18.49 0.728	2.502 0.0985	0.0406/0.1041 0.0016/0.0041	64 a 68 N.m	 4 Piezas 4 Piezas 1 Pieza 1 Pieza
53.957/53.978 2.124/2.125	58.999/59.017 2.323/2.324	24.94 0.982	2.502 0.0985	0.0406/0.1041 0.0016/0.0041	47 a 50 Lbs.Ft	
42.959/42.972 1.691/1.692	45.999/46.025 1.811/1.812	14.99 0.590	1.499 0.0590	0.0279/0.0990 0.0011/0.0039		1 Pieza
41.958/41.974 1.652/1.653	44.999/45.024 1.772/1.773	14.99 0.590	1.499 0.0590	0.0279/0.0990 0.0011/0.0039		1 Pieza
47.757/47.777 1.880/1.881	50.599/50.620 1.992/1.993	19.00 0.748	1.405 0.0553	0.0228/0.0812 0.0009/0.0032	30 N.m + 90° 22 Lbs.Ft + 90°	 8 Piezas
53.957/53.978 2.124/2.125	58.999/59.017 2.323/2.324	18.49 0.728	2.502 0.0985	0.0406/0.1041 0.0016/0.0041	64 a 68 N.m	 4 Piezas 4 Piezas 1 Pieza 1 Pieza
53.957/53.978 2.124/2.125	58.999/59.017 2.323/2.324	24.94 0.982	2.502 0.0985	0.0406/0.1041 0.0016/0.0041	47 a 50 Lbs.Ft	

CHRYSLER DODGE JEEP PLYMOUTH

4 CILINDROS / 4 CYLINDER		
MOTOR / ENGINE	AÑO / YEAR	LINEA / LINE
G4HC (1.0L)	2000-05	1
1086cc (1.1L) SOHC 12V	2000-05	1
86 G12B (1.4L) Mits. SOHC 8 valve	1979-84	2
92 4G15 (1.4L) Mits. SOHC 8 valve, carb. 4G15	1985-90	2
92 4G15 (1.4L) Mits. SOHC 8 valve, F.I.	1987-90	2
92 4G15 (1.4L) Mits. SOHC 12 valve	1991-94	2
98 4G61 (1.6L) Mits. DOHC 16 valve	1990	3
98 4G61T (1.6L) Mits. Turbo DOHC 16 valve	1989	3
98 G32BT (1.6L) Mits. Turbo SOHC 8 valve	1971-84	3
98 G32B (1.6L) Mits. SOHC 8 valve, Type K & Z	1971-84	3
107 4G37 (1.8L) Mits. SOHC 8 valve	1989-92	3
122 4G63 (2.0L) Mits. SOHC 8 valve	1983-92	3
122 4G63 (2.0L) Mits. DOHC 16 valve	1989-94	3
122 4G63T (2.0L) Mits. Turbo DOHC 16 valve	1989-94	3
122 (2.0L) SOHC 16 valve	1995-06	4
122 (2.0L) DOHC 16 valve	1995-99	4
122 (2.0L) G52B Mits. SOHC 8 valve	1974-82	5
135 (2.2L) SOHC 8 valve	1981-94	6
135 (2.2L) DOHC 8 valve	1988-91	6
135 (2.2L) Turbo SOHC 8 valve	1984-90	6
135 (2.2L) Turbo DOHC 16 valve	1988-93	6
144 4G64 (2.4L) Mits. SOHC 8 valve	1989-94	3
144 4G64 (2.4L) Mits. SOHC 8 valve	1993-94	3
148 (2.4L) DOHC, 16 Valve	1995-04	7
148 (2.4L) Turbo DOHC 16 valve	2003-04	7
150 (2.5L) Jeep OHV	1983-02	8
151 (2.5L) Pontiac Engine OHV	1980-83	10
153 (2.5L) SOHC 8 valve	1986-95	9
153 (2.5L) Turbo SOHC 8 valve	1989-92	9
156 (2.6L) G54B Mits. SOHC 8 valve, Type F	1978-87	5
156 (2.6L) G54B Mits. SOHC 8 valve, Type W	1979-90	5
156 (2.6L) G54B Mits. Turbo SOHC 8 valve	1984-90	5

6 CILINDROS / 6 CYLINDER		
MOTOR / ENGINE	AÑO / YEAR	LINEA / LINE
153 (2.5L) 6G73 Mits. EEB SOHC 24 valve	1995-00	11
167 (2.7L) DOHC 24 valve	1998-05	12
170 (2.8L) OHV	1960-71	13
173 (2.8L) Chevrolet OHV, First Design- Small Journal Size 63.3mm	1980-85	14
181 (3.0L) 6G72 Mits. SOHC 12 valve	1987-00	15
181 (3.0L) 6G72 Mits. DOHC 24 valve	1991-96	15
181 (3.0L) 6G72 Mits. Turbo DOHC 24 valve	1991-96	15
181 (3.0L) 6G72 DOHC (Nat. Asp.)	1991-99	15
198 (3.2L) OHV	1969-76	13
201 (3.3L) OHV	1990-06	16
215 (3.5L) OHV Chrysler V6 Engine	1993-97	17

CHRYSLER DODGE JEEP PLYMOUTH





6 CILINDROS / 6 CYLINDER		
MOTOR / ENGINE	AÑO / YEAR	LINEA / LINE
225 (3.7L) Buick engine OHV	1965-71	18
225 (3.7L) H225, HA225, HB225, HC225	1960-87	19
225 (3.7L) OHV	1960-87	20
226 (3.7L) EKG SOHC 12 valve	2002-06	21
231 (3.8L) OHV	1991-06	16
232 (3.8L) AMC OHV	1965-78	22
239 (3.9L) OHV Dodge Truck V6 Engine	1987-03	23
242 (4.0L) Jeep OHV	1987-02	22
258 (4.2L) AMC OHV	1971-90	22
258 (4.2L) AMC OHV	1987-90	22
258 (4.2L) AMC OHV	1991-02	22





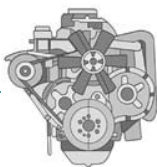

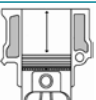
8 CILINDROS / 8 CYLINDER		
MOTOR / ENGINE	AÑO / YEAR	LINEA / LINE
273 (4.5L) OHV	1964-69	24
277 (4.6L) OHV	1956-57	24
287 (4.7L) SOHC 16 valve	1999-05	25
301 (4.9L) OHV	1957	24
303 (5.0L) OHV	1956	24
313 (5.1L) OHV	1957-58	24
318 (5.2L) OHV	1957-73	24
318 (5.2L) OHV	1974-03	24
318 (5.2L) OHV	1993-98	24
326 (5.3L) OHV	1959	24
340 (5.7L) OHV	1968-73	26
350 (5.7L) Buick OHV	1968-71	27
350 (5.7L) OHV	1958	28
361 (5.9L) OHV	1958-77	28
361.1 (5.9L) OHV	1966-67	28
360 (5.9L) OHV	1971-03	29
360 (5.9L) OHV	1974-01	29
360 (5.9L) OHV	1971-73	29
360 (5.9L) Chrysler OHV	1974-01	29
360 (5.9L) OHV	1971-78	29
360 (5.9L) OHV	1979-99	29
383 (6.3L) OHV	1959-60	30
383 (6.4L) OHV	1961-71	28
400 (6.6L) OHV	1972-80	28
413 (6.8L) OHV	1959-77	30
413 (6.8L) OHV HT413	1960-77	30
426 (7.0L) OHV Wedge	1963-65	30
426 (7.0L) HEMI	1964-71	30
440 (7.2L) OHV	1966-80	30
440-3 (7.2L) OHV	1972-80	30

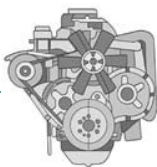
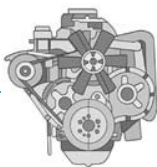
CHRYSLER

MORESA!

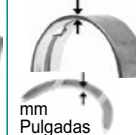
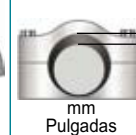
CHRYSLER DODGE JEEP PLYMOUTH



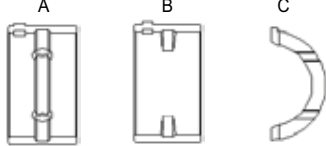
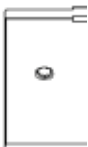
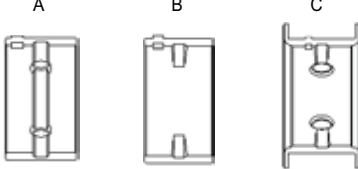
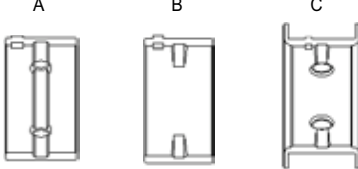

CIL.	AÑO	MOTOR / APLICACIÓN		Diámetro del Cilindro Nominal Bore	Carrera Stroke	COJINETE, BUJE O ARANDELA	No. de Parte	Ubicación Location
CYL.	YEAR	ENGINE / APPLICATION		 mm Pulgadas	 mm Pulgadas	BEARING, BUSHING OR THURST WASHER	Part Number	
1	2000-05	G4HC (1.0L) (999 cc) Atos, Atos Prime		66.00 2.598	73.00 2.874	COJINETE DE BIELA	4B7000 STD 25MM 50MM	TODOS
	2000-08	1086cc (1.1L) SOHC 12V (1086 cc) Atos, Atos Prime		67.00 2.638	77.00 3.031			
2	1979-84	86 G12B (1.4L) Mits. SOHC 8 valve (1409 cc) Champ, Colt		73.99 2.913	81.99 3.228	COJINETE DE BIELA	4B1278 STD 010 020 030 040	TODOS
	1985-90	92 4G15 (1.4L) Mits. SOHC 8 valve, carb. 4G15 (1448 cc) Colt, Summit, Vista		75.50 2.972	82.00 3.228			
	1987-90	92 4G15 (1.4L) Mits. SOHC 8 valve, F.I. (1448 cc) Colt, Summit, Vista		75.50 2.972	82.00 3.228	COJINETE DE BANCADA	5C1668 STD 010 020 030	3 (C)
	1991-94	92 4G15 (1.4L) Mits. SOHC 12 valve (1448 cc) Colt, Summit, Vista		75.50 2.972	82.00 3.228			

Diámetro Estándar del Muñón Standard Shaft Diameter	Diámetro Total del Alojamiento Housing Bore	Ancho del Cojinete Width Bearing	Espesor Máximo de Pared Max Wall Thickness	Claro de Lubricación Oil Clearance	Torque Torque	Imagen del Cojinete / Arandela Image of the Bearing and Thrust Washer
						
37.986/38.001 1.496/1.496	40.965/40.991 1.613/1.614	14.61 0.575	1.499 0.0590	0.0177/0.0355 0.0007/0.0014	Paso 1 14 a 16 N.m 10 a 12 Lbs.Ft Paso 2 27 a 31 N.m 20 a 23 Lbs.Ft	 8 Piezas
41.966/41.994 1.652/1.653	45.987/46.012 1.811/1.812	16.13 0.635	1.981 0.0780	0.0127/0.0406 0.0005/0.0016	Paso 1 34 a 38 N.m 25 a 28 Lbs.Ft Paso 2 68 a 92 N.m 50 a 55 Lbs.Ft	 5 Piezas 5 Piezas 2 Piezas
41.979/41.999 1.653/1.654	45.001/45.022 1.772/1.773	17.63 0.694	1.494 0.0588	0.0279/0.0889 0.0011/0.0035	33 a 34 N.m 24 a 25 Lbs.Ft	 8 Piezas
47.981/48.001 1.889/1.890	51.999/52.019 2.047/2.048	19.13 0.753	1.989 0.0783	0.0279/0.0863 0.0011/0.0034	50 a 53 N.m	 4 Piezas 4 Piezas 2 Piezas
47.981/48.001 1.889/1.890	51.999/52.019 2.047/2.048	23.95 0.943	1.989 0.0783	0.0279/0.0863 0.0011/0.0034	37 a 39 Lbs.Ft	 4 Piezas 4 Piezas 2 Piezas

CHRYSLER

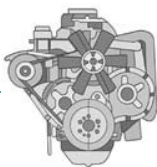

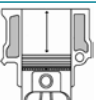

MORESA!

CHRYSLER DODGE JEEP PLYMOUTH

CIL.	AÑO	MOTOR / APLICACIÓN		Diámetro del Cilindro Nominal Bore	Carrera Stroke	COJINETE, BUJE O ARANDELA	No. de Parte	Ubicación Location
CYL.	YEAR	ENGINE / APPLICATION		 mm Pulgadas	 mm Pulgadas	BEARING, BUSHING OR THURST WASHER	Part Number	
L4	1990	98 4G61 (1.6L) Mits. DOHC 16 valve (1595 cc) Colt, Summit, Vista	82.30 3.240	75.00 2.953	COJINETE DE BIELA	4B1120 STD 010 020 030	1 2 3 4 5 →	TODOS
	1989	98 4G61T (1.6L) Mits. Turbo DOHC 16 valve (1595 cc) Colt, Summit, Vista	82.30 3.240	75.00 2.953				
	1971-84	98 G32BT (1.6L) Mits. Turbo SOHC 8 valve (1601 cc) Colt	76.90 3.027	86.00 3.385	COJINETE DE BANCADA	5C1559 STD 010 020 030 040	1 2 3 4 5 →	1-2-4-5 (A, B)
	1971-84	98 G32B (1.6L) Mits. SOHC 8 valve, Type K & Z (1601 cc) Arrow, Challenger, Champ, Colt, Sapporo	76.90 3.027	86.00 3.385				
	1989-92	107 4G37 (1.8L) Mits. SOHC 8 valve (1771 cc) Colt, Laser	81.00 3.188	86.00 3.385				
	1983-92	122 4G63 (2.0L) Mits. SOHC 8 valve (1996 cc) Colt, Ram, Vista	85.00 3.343	88.00 3.465	BUJE DE ARBOL	MO1810M STD	1 2 3 4 5 →	1
	1989-94	122 4G63 (2.0L) Mits. DOHC 16 valve (1996 cc) Laser, Talon, Vista	84.91 3.343	88.00 3.465				
	1989-94	122 4G63T (2.0L) Mits. Turbo DOHC 16 valve (1996 cc) Laser, Talon	85.00 3.343	88.00 3.465				
	1989-94	144 4G64 (2.4L) Mits. SOHC 8 valve (2350 cc) Colt, Ram, Summit, Vista	86.50 3.385	100.00 3.937				
	1993-94	144 4G64 (2.4L) Mits. SOHC 8 valve (2350 cc) Colt, Ram, Summit, Vista	86.50 3.385	100.00 3.937				

Línea Line



3







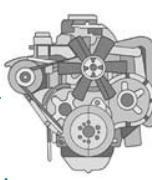
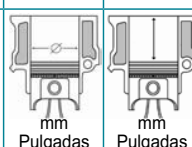
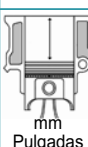

Diámetro Estándar del Muñón Standard Shaft Diameter	Diámetro Total del Alojamiento Housing Bore	Ancho del Cojinete Width Bearing	Esesor Máximo de Pared Max Wall Thickness	Claro de Lubricación Oil Clearance	Torque Torque	Imagen del Cojinete / Arandela Image of the Bearing and Thrust Washer
mm Pulgadas	mm Pulgadas	mm Pulgadas	mm Pulgadas	mm Pulgadas	N.m Lbs.Ft	
44.981/45.001 1.771/1.772	48.003/48.016 1.890/1.890	23.60 0.929	1.494 0.0588	0.0152/0.0762 0.0006/0.0030	31 a 34 N.m 23 a 25 Lbs.Ft	 8 Piezas
56.985/57.000 2.244/2.244	61.001/61.021 2.402/2.402	23.09 0.909	1.991 0.0784	0.0203/0.0812 0.0008/0.0032	49 a 53 N.m 36 a 39 Lbs.Ft	 A  B  C 4 Piezas 4 Piezas 2 Piezas
56.985/57.000 2.244/2.244	61.001/61.021 2.402/2.402	28.96 1.140	1.991 0.0784	0.0203/0.0812 0.0008/0.0032		
41.976 1.653	45.024 1.773	19.00 0.748	1.506 0.0593	0.0254/0.0787 0.0010/0.0031		1 PIEZA
40.968 1.613	44.026 1.7333	21.00 0.827	1.496 0.0589	0.0254/0.0787 0.0010/0.0031		2 PIEZAS

CHRYSLER

MORESA!

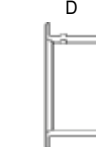
CHRYSLER DODGE JEEP PLYMOUTH



CIL.	AÑO	MOTOR / APLICACIÓN		Diámetro del Cilindro Nominal Bore	Carrera Stroke	COJINETE, BUJE O ARANDELA	No. de Parte	Ubicación Location
CYL.	YEAR	ENGINE / APPLICATION		 mm Pulgadas	 mm Pulgadas	BEARING, BUSHING OR THURST WASHER	Part Number	
4	L4	1995-06	122 (2.0L) SOHC 16 valve (1996 cc) Breeze, Neon	87.49 3.444	83.00 3.268	COJINETE DE BIELA	4B1635 STD 010 020 030	TODOS
		1995-99	122 (2.0L) DOHC 16 valve (1996 cc) Avenger, Neon, Sebring, Stratus	87.49 3.444	83.00 3.268			
							3 (C, D)	
5	L4	1974-82	122 (2.0L) G52B Mits. SOHC 8 valve (2000 cc) Arrow, Colt	84.00 3.307	90.00 3.543	COJINETE DE BIELA	4B1220 STD 010 020 030 040	TODOS
		1978-87	156 (2.6L) G54B Mits. SOHC 8 valve, Type F (2600 cc) Aries, Arrow, Caravan, Caravelle, Challenger, Colt, E-Class, Grand Caravan, Lebaron, New Yorker, Ram, Reliant, Sapporo, Voyager	91.00 3.582	97.99 3.858			
		1979-90	156 (2.6L) G54B Mits. SOHC 8 valve, Type W (2600 cc) Arrow, Conquest, Raider, Ram	91.00 3.582	97.99 3.858			3 (C)
		1984-90	156 (2.6L) G54B Mits. Turbo SOHC 8 valve (2600 cc) Conquest	91.00 3.582	97.99 3.858	BUJE DE ARBOL	MO1805M STD	1-2
								3

Diámetro Estándar del Muñón Standard Shaft Diameter	Diámetro Total del Alojamiento Housing Bore	Ancho del Cojinete Width Bearing	Esesor Máximo de Pared Max Wall Thickness	Claro de Lubricación Oil Clearance	Torque Torque	Imagen del Cojinete / Arandela Image of the Bearing and Thrust Washer
mm Pulgadas	mm Pulgadas	mm Pulgadas	mm Pulgadas	mm Pulgadas	N.m Lbs.Ft	
47.991/48.006 1.889/1.890	50.991/51.006 2.008/2.008	20.47 0.806	1.483 0.0584	0.0254/0.0584 0.0010/0.0023	27 N.m + 90° 20 Lbs.Ft + 90°	 8 Piezas
51.991/52.007 2.047/2.048	55.994/56.007 2.205/2.205	19.96 0.786	1.824 0.0718	0.0203/0.0609 0.0008/0.0024	41 N.m + 90°	A  B  C  D  4 Pzas. 4 Pzas. 1 Pieza 1 Pieza
51.991/52.007 2.047/2.048	51.943/52.070 2.045/2.050	26.26 1.034	1.991 0.0784	0.0203/0.0609 0.0008/0.0024	30 Lbs.Ft + 90°	
52.979/53.000 2.086/2.087	55.999/56.020 2.205/2.206	24.99 0.984	1.499 0.059	0.0127/0.0711 0.0005/0.0028	45 a 46 N.m 33 a 34 Lbs.Ft	 8 Piezas
59.980/60.000 2.361/2.362	64.000/64.021 2.520/2.521	25.13 0.989	1.991 0.0784	0.0279/0.0939 0.0011/0.0037	75 a 83 N.m	A  B  C  4 Piezas 4 Piezas 2 Piezas
59.980/60.000 2.361/2.362	64.000/64.021 2.520/2.521	30.96 1.219	1.991 0.0784	0.0279/0.0939 0.0011/0.0037	55 a 61 Lbs.Ft	
43.010/43.025 1.693/1.694	46.0298/46.0502 1.8122/1.8130	20.19 0.795	1.486 0.0585	0.0330/0.0939 0.0013/0.0037		2 Piezas
22.959/22.979 0.904/0.905	25.9994/26.0197 1.0236/1.0244	18.01 0.709	1.506 0.0593	0.0203/0.0863 0.0008/0.0034		1 Pieza

CHRYSLER

MORESA

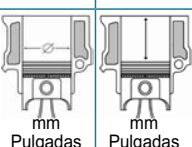
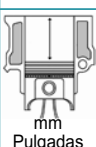
CHRYSLER DODGE JEEP PLYMOUTH

CIL.	AÑO	MOTOR / APLICACIÓN		Diámetro del Cilindro Nominal Bore	Carrera Stroke	COJINETE, BUJE O ARANDELA	No. de Parte	Ubicación Location
CYL.	YEAR	ENGINE / APPLICATION		 mm Pulgadas	 mm Pulgadas	BEARING, BUSHING OR THURST WASHER	Part Number	
L4	1981-94	135 (2.2L) SOHC 8 valve (2200 cc) Caravan, Caravelle, Charger, Dakota, Daytona, E-Class, Grand Caravan, Grand Voyager, Horizon, Lancer, Laser, Lebaron, New Yorker, Omni, Ram, Rampage, Reliant, Scamp, Shadow, Spirit, Dart K, Sundance, TC3, Voyager	87.50 3.445	91.99 3.622	COJINETE DE BIELA	4B1269 STD 010 020 030	TODOS	
	1988-91	135 (2.2L) DOHC 8 valve (2200 cc) Daytona, TC	87.50 3.445	91.99 3.622	COJINETE DE BANCADA	5C1533 STD 010 020 030	1-2-4-5 (A)	
							3 (B, C)	
	1984-90	135 (2.2L) Turbo SOHC 8 valve (2200 cc) Caravelle, Charger, Daytona, E-Class, Lancer, Laser, Lebaron, Omni, Shadow, Sundance	87.50 3.445	91.99 3.622	BUJE DE FLECHA AUXILIAR	MO1487M STD	1	
	1988-93	135 (2.2L) Turbo DOHC 16 valve (2200 cc) Daytona, TC	87.50 3.445	91.99 3.622			2	
				BUJE DE FLECHA BALANCEADORA	MO1792M STD	1		
L4	1995-04	148 (2.4L) DOHC, 16 Valve (2429 cc) Breeze, Caravan, Cirrus, Grand Caravan, Grand Voyager, PT Cruiser, Sebring, Stratus, Voyager	87.38 3.440	101.09 3.980	COJINETE DE BIELA	4B4565 STD 010 020 030 040	TODOS	
	2003-04	148 (2.4L) Turbo DOHC 16 valve (2429 cc) PT Cruiser, SRT-4	87.38 3.440	101.09 3.980	COJINETE DE BANCADA	5C7313 STD 010 020 030 040	1-2-4-5 (A)	
				3 (B)				

Línea Line
6



7

Diámetro Estándar del Muñón Standard Shaft Diameter	Diámetro Total del Alojamiento Housing Bore	Ancho del Cojinete Width Bearing	Espesor Máximo de Pared Max Wall Thickness	Claro de Lubricación Oil Clearance	Torque Torque	Imagen del Cojinete / Arandela Image of the Bearing and Thrust Washer
49.980/50.005 1.968/1.969	52.992/53.007 2.086/2.087	20.17 0.794	1.483 0.0584	0.02037/0.0863 0.0008/0.0034	54 N.m + 90° 40 Lbs.Ft + 90°	 8 Piezas
59.987/60.013 2.362/2.363	63.993/64.013 2.519/2.520	21.62 0.851	1.986 0.0782	0.0203/0.0838 0.0008/0.0033	41 N.m + 90°	A B C
59.987/60.013 2.362/2.363	63.993/64.013 2.519/2.520	27.86 1.097	1.986 0.0782	0.0203/0.0838 0.0008/0.0033	30 Lbs.Ft + 90°	8 Piezas 1 Pieza 1 Pieza
42.669/42.695 1.680/1.681	45.969/46.030 1.810/1.812	19.00 0.748	1.633 0.0643	0.0330/0.0787 0.0013/0.0031		1 Pieza
19.670/19.693 0.774/0.775	22.969/23.030 0.904/0.907	21.01 0.827	1.633 0.0643	0.0330/0.0787 0.0013/0.0031		1 Pieza
39.776/42.088 1.656/1.657	45.364/45.390 1.786/1.787	22.50 0.886	2.007 0.0790	0.0457/0.0635 0.0018/0.0025		1 Pieza
50.008/50.025 1.969/1.970	52.995/53.007 2.086/2.087	20.17 0.794	1.483 0.0584	0.0203/0.0863 0.0008/0.0034	27 N.m + 90° 20 Lbs.Ft + 90°	 8 Piezas
59.992/60.008 2.362/2.363	64.000/64.013 2.520/2.520	21.62 0.851	1.984 0.0781	0.0127/0.0736 0.0005/0.0029	M11 = 81 N.m M8 = 34 N.m	A B
59.992/60.008 2.362/2.363	64.000/64.013 2.520/2.520	27.86 1.097	2.162 0.0851	0.0127/0.0736 0.0005/0.0029	M11 = 60 Lbs.Ft M8 = 25 Lbs.Ft	8 Piezas 2 Piezas

CHRYSLER

MORESA

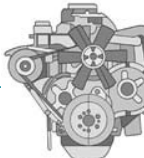
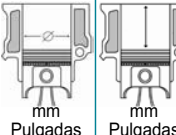
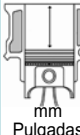
CHRYSLER DODGE JEEP PLYMOUTH

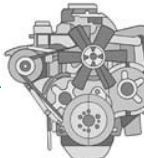
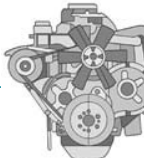
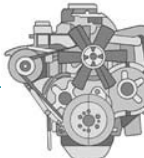
CIL.	AÑO	MOTOR / APLICACIÓN		Diámetro del Cilindro Nominal Bore	Carrera Stroke	COJINETE, BUJE O ARANDELA	No. de Parte	Ubicación Location
CYL.	YEAR	ENGINE / APPLICATION		 mm Pulgadas	 mm Pulgadas	BEARING, BUSHING OR THURST WASHER	Part Number	
L4	1983-02	150 (2.5L) Jeep OHV (2460 cc) CJ7, Cherokee, Comanche, Scrambler, T.J, Wagoneer, Wrangler		98.55 3.880	81.03 3.190	COJINETE DE BIELA	4B960 STD 010 020 030 040	TODOS
						COJINETE DE BANCADA 1983-90	5C1568 STD 010 020 030 040	1-3-4-5 (A, B)
						COJINETE DE BANCADA 1981-02	5C1948 STD 010 020 030 040	1-3-4-5 (A, B) 2 (C, D)
L4	1986-95	153 (2.5L) SOHC 8 valve (2500 cc) Acclaim, Aries, Caravan, Caravelle, Dakota, Daytona, Dynasty, Grand Caravan, Grand Voyager, Lancer, Laser, Lebaron, New Yorker, Ram, Reliant, Shadow, Spirit, Dart K, Sundance, Voyager		87.50 3.444	108.00 4.251	COJINETE DE BIELA	4B1269 STD 010 020 030	TODOS
						COJINETE DE BANCADA	5C1533 STD 010 020 030	1-2-4-5 (A)
	1989-92	153 (2.5L) Turbo SOHC 8 valve (2500 cc) Daytona, Grand Caravan, Grand Voyager, Lancer, Lebaron, Shadow, Spirit, Sundance, Voyager		87.50 3.444	108.00 4.251	BUJE DE FLECHA AUXILIAR	MO1487M STD	1
						BUJE DE FLECHA BALANCEADORA	MO1792M STD	2

Línea Line 8





9

Diámetro Estándar del Muñón Standard Shaft Diameter	Diámetro Total del Alojamiento Housing Bore	Ancho del Cojinete Width Bearing	Espesor Máximo de Pared Max Wall Thickness	Claro de Lubricación Oil Clearance	Torque Torque	Imagen del Cojinete / Arandela Image of the Bearing and Thrust Washer
53.208/53.226 2.095/2.096	56.083/56.096 2.208/2.209	21.26 0.837	1.422 0.056	0.0304/0.0863 0.0012/0.0034	45 N.m 33 Lbs.Ft	 8 Piezas
63.470/63.487 2.499/2.500	68.351/68.377 2.691/2.692	25.04 0.986	2.421 0.0953	0.0152/0.0762 0.0006/0.0031	109 N.m 80 Lbs.Ft	A B C D 4 Piezas 4 Piezas 1 Pieza 1 Pieza
63.470/63.487 2.499/2.500	68.351/68.377 2.691/2.692	32.26 1.270	2.421 0.0953	0.0076/0.0711 0.0003/0.0028	80 Lbs.Ft	A B C D 4 Piezas 4 Piezas 1 Pieza 1 Pieza
63.470/63.487 2.499/2.500	68.351/68.377 2.691/2.692	25.04 0.986	2.421 0.0953	0.0152/0.0762 0.0006/0.0031	102 a 109 N.m	A B C D 4 Piezas 4 Piezas 1 Pieza 1 Pieza
63.470/63.487 2.499/2.500	68.351/68.377 2.691/2.692	32.26 1.270	2.421 0.0953	0.0152/0.0762 0.0006/0.0031	75 a 80 Lbs.Ft	A B C D 4 Piezas 4 Piezas 1 Pieza 1 Pieza
49.980/50.005 1.968/1.969	52.992/53.007 2.086/2.087	20.17 0.794	1.483 0.0584	0.0203/0.0863 0.0008/0.0034	54 N.m + 90° 40 Lbs.Ft + 90°	 8 Piezas
59.987/60.013 2.362/2.363	63.993/64.013 2.519/2.520	21.62 0.851	1.986 0.0782	0.0203/0.0838 0.0008/0.0033	41 N.m + 90°	A B C 8 Piezas 1 Pieza 1 Pieza
59.987/60.013 2.362/2.363	63.993/64.013 2.519/2.520	27.86 1.097	1.986 0.0782	0.0203/0.0838 0.0008/0.0033	30 Lbs.Ft + 90°	A B C 8 Piezas 1 Pieza 1 Pieza
42.669/42.695 1.680/1.681	45.969/46.030 1.810/1.812	19.00 0.748	1.633 0.0643	0.0330/0.0787 0.0013/0.0031		1 Pieza
19.670/19.693 0.774/0.775	22.969/23.030 0.904/0.907	21.01 0.827	1.633 0.0643	0.0330/0.0787 0.0013/0.0031		1 Pieza
39.776/42.088 1.656/1.657	45.364/45.390 1.786/1.787	22.50 0.886	2.0066 0.0790	0.0457/0.0635 0.0018/0.0025		1 Pieza

CHRYSLER

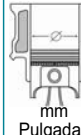
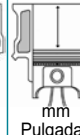
MORESA!

CHRYSLER DODGE JEEP PLYMOUTH





CIL.	AÑO	MOTOR / APLICACIÓN		Diámetro del Cilindro Nominal Bore	Carrera Stroke	COJINETE, BUJE O ARANDELA	No. de Parte	Ubicación Location
CYL.	YEAR	ENGINE / APPLICATION		 mm Pulgadas	 mm Pulgadas	BEARING, BUSHING OR THURST WASHER	Part Number	
10	L4	1980-83 151 (2.5L) Pontiac Engine OHV (2500 cc) CJ5, CJ7, Scrambler		101.60 4.000	76.20 3.000	COJINETE DE BIELA	4B610 STD 010 020 030 040	TODOS
						COJINETE DE BANCADA	5C1733 STD 010 020 030	1-2-3-4 (A, B)
								5 (C, D)
COJINETE DE BANCADA	5C616 STD 010 020 030 040	1-2-3-4 (A, B)						
		5 (C, D)						
11	V6	1995-00 153 (2.5L) 6G73 Mits. EEB SOHC 24 valve (2497 cc) Avenger, Cirrus, Sebring, Stratus		83.50 3.287	76.00 2.992	COJINETE DE BIELA	6B1411 STD 010 020 030	TODOS
						ARANDELA	AM458 STD	3

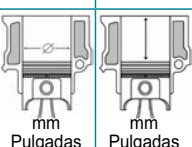
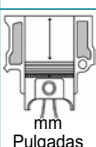

Diámetro Estándar del Muñón Standard Shaft Diameter	Diámetro Total del Alojamiento Housing Bore	Ancho del Cojinete Width Bearing	Espesor Máximo de Pared Max Wall Thickness	Claro de Lubricación Oil Clearance	Torque Torque	Imagen del Cojinete / Arandela Image of the Bearing and Thrust Washer
50.787/50.813 2.000/2.001	53.967/53.980 2.125/2.125	18.85 0.742	1.575 0.0620	0.0177/0.0812 0.0007/0.0032	41 N.m 30 Lbs.Ft Excepto cabeza flujo cruzado 43 N.m 32 Lbs.Ft Cabeza flujo cruzado	 8 Piezas
58.377/58.402 2.298/2.299	63.261/63.287 2.491/2.492	20.50 0.807	2.426 0.0955	0.0177/0.0812 0.0007/0.0032	88 N.m 65 Lbs.Ft Excepto cabeza flujo cruzado	A B C D
58.377/58.402 2.298/2.299	63.246/63.287 2.490/2.492	25.63 1.009	2.426 0.0955	0.0177/0.0812 0.0007/0.0032	95 N.m 70 Lbs.Ft Cabeza flujo cruzado	4 Piezas 4 Piezas 1 Pieza 1 Pieza
58.377/58.402 2.298/2.299	63.261/63.287 2.491/2.492	20.50 0.807	2.426 0.0955	0.0076/0.0914 0.0003/0.0036	88 N.m 65 Lbs.Ft Excepto cabeza flujo cruzado	A B C D
58.377/58.402 2.298/2.299	63.246/63.287 2.490/2.492	25.63 1.009	2.426 0.0955	0.0076/0.0914 0.0003/0.0036	95 N.m 70 Lbs.Ft Cabeza flujo cruzado	4 Piezas 4 Piezas 1 Pieza 1 Pieza
49.972/50.000 1.967/1.969	53.000/53.020 2.087/2.087	15.39 0.606	1.491 0.0587	0.0228/0.0685 0.0009/0.0027	51 N.m 38 Lbs.Ft	 8 Piezas
65.999/66.251 2.598/2.608	77.699/77.953 3.059/3.069		1.974 0.0777			4 Piezas

CHRYSLER

MORESA

CHRYSLER DODGE JEEP PLYMOUTH

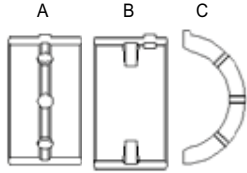

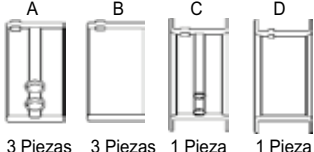
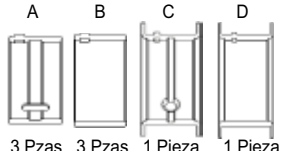
CIL.	AÑO	MOTOR / APLICACIÓN		Diámetro del Cilindro Nominal Bore	Carrera Stroke	COJINETE, BUJE O ARANDELA	No. de Parte	Ubicación Location
CYL.	YEAR	ENGINE / APPLICATION		 mm Pulgadas	 mm Pulgadas	BEARING, BUSHING OR THURST WASHER	Part Number	
12	V6	1998-05 167 (2.7L) DOHC 24 valve (2735 cc) 300, Charger, Concorde, Intrepid, Magnum, Sebring, Stratus		86.00 3.385	78.50 3.091	COJINETE DE BIELA	6B1670 STD 25MM 50MM	TODOS
						COJINETE DE BANCADA	4C2209 STD 25MM 50MM	1-2-3-4 (A, B)
								3 (C)
13	L6	1960-71 170 (2.8L) OHV 2800cc A100, Dart, Lancer, P200, P300, Valiant		86.36 3.400	79.38 3.125	COJINETE DE BIELA	6B606 STD 010 020 030 040	TODOS
		1969-76 198 (3.2L) OHV (3200cc) A100, Challenger, Dart, Duster, Ram, Scamp, Valiant				86.36 3.400	92.45 3.640	COJINETE DE BIELA
				COJINETE DE BANCADA	4C517 STD 010 020 030 040	1-2-4 (A, B) 3 (C, D)		
				COJINETE DE BANCADA	4C1419 STD 010 020 030 040	1-2-4 (A, B) 3 (C, D)		
				BUJE DE ARBOL	MO1473M STD 010	1 2 3 4		





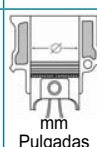
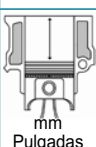

Diámetro Estándar del Muñón Standard Shaft Diameter	Diámetro Total del Alojamiento Housing Bore	Ancho del Cojinete Width Bearing	Espesor Máximo de Pared Max Wall Thickness	Claro de Lubricación Oil Clearance	Torque	Imagen del Cojinete / Arandela Image of the Bearing and Thrust Washer
mm Pulgadas	mm Pulgadas	mm Pulgadas	mm Pulgadas	mm Pulgadas	N.m Lbs.Ft	
53.492/53.510 2.106/2.107	56.492/56.507 2.224/2.225	17.37 0.684	1.486 0.0585	0.0152/0.0762 0.0006/0.0030	27 N.m + 90° 20 Lbs.Ft + 90°	 12 Piezas
63.492/63.510 2.500/2.500	68.994/69.009 2.716/2.717	18.69 0.736	2.741 0.1079	0.0101/0.0736 0.0004/0.0029	20 N.m + 90° 15 Lbs.Ft + 90° Tornillos interiores 27 N.m + 90° 20 Lbs.Ft + 90° Tornillos exteriores	 4 Piezas 4 Piezas 2 Piezas
71.100/71.351 2.799/ 2.809	90.190/90.439 3.551/3.561		2.055 0.0809			
55.537/55.563 2.187/2.188	58.738/58.750 2.313/2.313	25.15 0.990	1.585 0.0624	0.0177/0.0711 0.0007/0.0028	61 N.m 45 Lbs.Ft	 12 Piezas
55.537/55.563 2.187/2.188	58.738/58.750 2.313/2.313	18.29 0.720	1.582 0.0623	0.0101/0.0736 0.0004/0.0029	61 N.m 45 Lbs.Ft	 12 Piezas
69.837/69.863 2.750/2.751	74.740/74.752 2.943/2.943	26.39 1.039	2.436 0.0959	0.0254/0.1524 0.0010/0.0060	115 N.m	 3 Piezas 3 Piezas 1 Pieza 1 Pieza
69.837/69.863 2.750/2.751	74.740/74.752 2.943/2.943	31.88 1.255	2.436 0.0959	0.0127/0.0660 0.0005/0.0026	85 Lbs.Ft	
69.837/69.863 2.750/2.751	74.740/74.752 2.943/2.943	22.40 0.882	2.436 0.0959	0.0127/0.0660 0.0005/0.0026	115 N.m	 3 Pzas. 3 Pzas. 1 Pieza 1 Pieza
69.837/69.863 2.750/2.751	74.740/74.752 2.943/2.943	28.14 1.108	2.436 0.0959	0.0127/0.0660 0.0005/0.0026	85 Lbs.Ft	
50.749/50.775 1.998/1.999	54.089/54.115 2.130/2.131	23.37 0.920	1.638 0.0645	0.0635/0.1651 0.0025/0.0065		1 Pieza
50.343/50.368 1.982/1.983	53.683/53.708 2.114/2.115	19.05 0.750	1.638 0.0645	0.0635/0.1651 0.0025/0.0065		1 Pieza
49.962/49.987 1.967/1.968	53.302/53.327 2.099/2.100	19.05 0.750	1.638 0.0645	0.0635/0.1651 0.0025/0.0065		1 Pieza
49.555/49.581 1.951/1.952	52.896/52.921 2.083/2.084	19.05 0.750	1.638 0.0645	0.0635/0.1651 0.0025/0.0065		1 Pieza

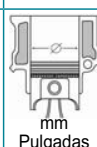
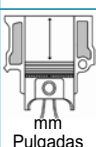
CHRYSLER

MORESA!

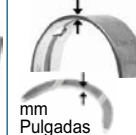
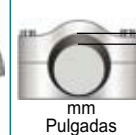
CHRYSLER DODGE JEEP PLYMOUTH



CIL.	AÑO	MOTOR / APLICACIÓN		Diámetro del Cilindro Nominal Bore	Carrera Stroke	COJINETE, BUJE O ARANDELA	No. de Parte	Ubicación Location
CYL.	YEAR	ENGINE / APPLICATION				BEARING, BUSHING OR THURST WASHER	Part Number	
14 V6	1980-85	173 (2.8L) Chevrolet OHV, First Design- Small Journal Size 63.3mm (2800 cc) Camaro, Celebrity, Century, Citation, Firebird, Omega, Phoenix, Riviera, S10, S15, Skylark Cherokee, Comanche, Wagoneer (JEEP)			COJINETE DE BIELA	6B1238 STD 010 020 030 040	TODOS	
							1 (A, B)	
							2 (C, D)	
							3 (E, F)	
							4 (G, H)	
							COJINETE DE BANCADA	4C1494 STD 010 020 030 040
2 (C, D)								
3 (E, F)								
COJINETE DE BANCADA	4C2037 STD 010 020 030 040	1-4 (A, B)						
2 (C, D)								
3 (E, F)								
15 V6	1987-00	181 (3.0L) 6G72 Mits. SOHC 12 valve (2972 cc)	91.10 3.586	75.99 2.992	COJINETE DE BIELA	6B1411 STD 010 020 030	TODOS	
	1991-96	181 (3.0L) 6G72 Mits. DOHC 24 valve (2972 cc) Acclaim, Caravan, Daytona, Dynasty, Grand Caravan, Grand Voyager, Lebaron, New Yorker, Raider, Shadow, Spirit, Stealth, Sundance, TC3, Voyager	91.10 3.586	75.99 2.992	COJINETE DE BANCADA	4C1720 STD 010 020 030	1-2-3-4 (A, B)	
	1991-96	181 (3.0L) 6G72 Mits. Turbo DOHC 24 valve (2972 cc) Stealth	91.10 3.586	75.99 2.992	COJINETE DE BANCADA	4C1720 STD 010 020 030	1-2-3-4 (A, B)	
	1991-99	181 (3.0L) 6G72 DOHC (Nat. Asp.) (2972 cc) Stealth	91.10 3.586	75.99 2.992	ARANDELA	AM458 STD	3	







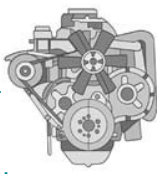





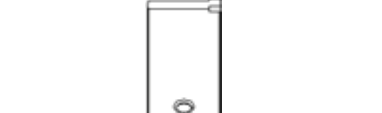

Diámetro Estándar del Muñón Standard Shaft Diameter	Diámetro Total del Alojamiento Housing Bore	Ancho del Cojinete Width Bearing	Espesor Máximo de Pared Max Wall Thickness	Claro de Lubricación Oil Clearance	Torque Torque	Imagen del Cojinete / Arandela Image of the Bearing and Thrust Washer
						
50.757/50.782 1.998/1.999	53.962/53.988 2.125/2.126	18.29 0.720	1.58 0.0622	0.0127/0.0889 0.0005/0.0035	46 a 54 N.m 34 a 40 Lbs.Ft	 12 Piezas
63.340/63.363 2.494/2.495	68.250/68.275 2.687/2.688	24.64 0.970	2.433 0.0958	0.0279/0.1016 0.0011/0.0040	85 a 100 N.m	A 1 Pieza
63.340/63.363 2.494/2.495	68.250/68.275 2.687/2.688	18.85 0.742	2.433 0.0958	0.0279/0.1016 0.0011/0.0040		B 1 Pieza
63.340/63.363 2.494/2.495	68.250/68.275 2.687/2.688	23.93 0.942	2.433 0.0958	0.0279/0.1016 0.0011/0.0040	63 a 74 Lbs.Ft	C 1 Pieza
63.340/63.363 2.494/2.495	68.250/68.275 2.687/2.688	31.70 1.248	2.433 0.0958	0.0279/0.1016 0.0011/0.0040		D 1 Pieza
67.239/67.264 2.647/2.648	72.149/72.174 2.841/2.842	24.82 0.977	2.426 0.0955	0.0381/0.0914 0.0015/0.0036	85 a 100 N.m	E 1 Pieza
67.239/67.264 2.647/2.648	72.149/72.174 2.841/2.842	18.75 0.738	2.426 0.0955	0.0381/0.0914 0.0015/0.0036		F 1 Pieza
67.239/67.264 2.647/2.648	72.149/72.174 2.841/2.842	23.93 0.942	2.426 0.0955	0.0381/0.0914 0.0015/0.0036	63 a 74 Lbs.Ft	G 1 Pieza
						H 1 Pieza
49.972/50.000 1.967/1.969	53.000/53.020 2.087/2.087	15.39 0.606	1.491 0.0587	0.0228/0.0685 0.0009/0.0027	52 N.m 38 Lbs.Ft	 8 Piezas
59.972/60.000 2.361/2.362	64.000/64.021 2.520/2.521	18.01 0.709	1.989 0.0783	0.0177/0.0863 0.0007/0.0034	81 N.m 60 Lbs.Ft	A 4 Piezas
						B 4 Piezas
65.999/66.251 2.598/2.608	77.699/77.953 3.059/3.069		1.974 0.0777			4 Piezas

CHRYSLER

MORESA!

CHRYSLER DODGE JEEP PLYMOUTH



CIL.	AÑO	MOTOR / APLICACIÓN		Diámetro del Cilindro Nominal Bore	Carrera Stroke	COJINETE, BUJE O ARANDELA	No. de Parte	Ubicación Location
CYL.	YEAR	ENGINE / APPLICATION		mm Pulgadas	mm Pulgadas	BEARING, BUSHING OR THURST WASHER	Part Number	
16	V6	1990-06	201 (3.3L) OHV (3300 cc) Caravan, Concorde, Dynasty, Grand Caravan, Grand Voyager, Imperial, Intrepid, New Yorker, Town & Country, Vision, Voyager	93.00 3.661	80.98 3.188	COJINETE DE BIELA	6B1410 STD 010 020 030 040	TODOS
	1991-06	231 (3.8L) OHV (3800 cc) Caravan, Grand Caravan, Grand Voyager, Imperial, New Yorker, Pacifica, Town & Country, Voyager	96.00 3.780	87.00 3.425	COJINETE DE BANCADA	4C1946 STD 010 020 030 040	1-3-4 (A, B)	
		COJINETE DE BANCADA	4C1946 STD 010 020 030 040	2 (C, D)				
		BUJE DE ARBOL	MO1809M STD	1 2 3 4				
17	V6	1993-97	215 (3.5L) OHV Chrysler V6 Engine (3500 cc) Concorde, Interpid, LHS, New Yorker, Prowler, Vision	86.00 3.385	91.00 3.582	COJINETE DE BIELA	6B1410 STD 010 020 030 040	TODOS
	COJINETE DE BANCADA	4C2010 STD 010 020 030	1-3-4 (A, B)					
		COJINETE DE BANCADA	4C2010 STD 010 020 030	2 (C, D)				
18	V6	1965-71	225 (3.7L) Buick engine OHV (3688 cc) CJ5, CJ5A, CJ6, CJ6A, DJ5, DJ6, Jeepster	95.25 3.750	86.36 3.400	COJINETE DE BIELA	6B610 STD 010 020	TODOS
	COJINETE DE BANCADA	4C960 STD 010 020 030	1-3 (A, B)					
		COJINETE DE BANCADA	4C960 STD 010 020 030	4 (A, C)				
		COJINETE DE BANCADA	4C960 STD 010 020 030	2 (D, E)				

Diámetro Estándar del Muñón Standard Shaft Diameter	Diámetro Total del Alojamiento Housing Bore	Ancho del Cojinete Width Bearing	Espesor Máximo de Pared Max Wall Thickness	Claro de Lubricación Oil Clearance	Torque	Imagen del Cojinete / Arandela Image of the Bearing and Thrust Washer
mm Pulgadas	mm Pulgadas	mm Pulgadas	mm Pulgadas	mm Pulgadas	N.m Lbs.Ft	
57.988/58.014 2.283/2.284	60.993/61.006 2.401/2.402	16.54 0.651	1.483 0.0584	0.0127/0.0558 0.0005/0.0022	54 N.m + 90 ° 40 Lbs.Ft + 90 °	 12 Piezas
63.988/64.013 2.519/2.520	67.993/68.014 2.677/2.678	17.63 0.694	1.984 0.0781	0.0127/0.0508 0.0005/0.0020	41 N.m + 90 °	A  B  C  D 
63.988/64.013 2.519/2.520	67.993/68.014 2.677/2.678	23.88 0.940	1.984 0.0781	0.0127/0.0508 0.0005/0.0020	30 Lbs.Ft + 90 °	3 Piezas 3 Piezas 1 Pieza 1 Pieza
50.724/50.775 1.997/1.999	54.089/54.115 2.130/2.131	23.75 0.935	1.643 0.0647	0.0254/0.1016 0.0010/0.0040		1 Pieza
50.292/50.343 1.980/1.982	53.683/53.708 2.114/2.115	15.62 0.615	1.659 0.0653	0.0254/0.1016 0.0010/0.0040		1 Pieza
49.911/49.962 1.965/1.967	53.302/53.327 2.099/2.100	15.62 0.615	1.659 0.0653	0.0254/0.1016 0.0010/0.0040		1 Pieza
49.530/49.581 1.950/1.952	52.896/52.921 2.083/2.084	15.62 0.615	1.643 0.0647	0.0254/0.1016 0.0010/0.0040		1 Pieza
57.988/58.014 2.283/2.284	60.993/61.006 2.401/2.402	16.54 0.651	1.483 0.0584	0.0127/0.0558 0.0005/0.0022	54 N.m + 90 ° 40 Lbs.Ft + 90 °	 12 Piezas
63.988/64.013 2.519/2.520	67.993/68.014 2.677/2.678	17.63 0.694	1.984 0.0781	0.0127/0.0508 0.0005/0.0020	41 N.m + 90 °	A  B  C  D 
63.988/64.013 2.519/2.520	67.993/68.014 2.677/2.678	23.88 0.940	1.984 0.0781	0.0127/0.0508 0.0005/0.0020	30 Lbs.Ft + 90 °	3 Piezas 3 Piezas 1 Pieza 1 Pieza
50.787/50.813 2.000/2.001	53.967/53.980 2.125/2.125	18.85 0.742	1.575 0.0620	0.0177/0.0812 0.0007/0.0032	41 a 54 N.m 30 a 40 Lbs.Ft	 12 Piezas
63.475/63.500 2.499/2.500	68.250/68.275 2.687/2.688	22.07 0.869	2.375 0.0935	0.0127/0.0762 0.0005/0.0034	129 a 163 N.m	A  B  C  D  E 
63.475/63.500 2.499/2.500	68.250/68.275 2.687/2.688	22.07 0.869	2.375 0.0935	0.0127/0.0762 0.0005/0.0034	95 a 120 Lbs.Ft	3 Piezas 2 Piezas 1 Pieza 1 Pieza 1 Pieza
63.475/63.500 2.499/2.500	68.250/68.275 2.687/2.688	26.87 1.058	2.375 0.0935	0.0127/0.0762 0.0005/0.0034		

CHRYSLER

MORESA!

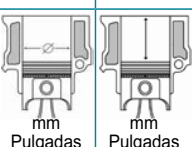
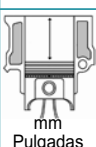
CHRYSLER DODGE JEEP PLYMOUTH





CIL.	AÑO	MOTOR / APLICACIÓN		Diámetro del Cilindro Nominal Bore	Carrera Stroke	COJINETE, BUJE O ARANDELA	No. de Parte	Ubicación Location
CYL.	YEAR	ENGINE / APPLICATION		 mm Pulgadas	 mm Pulgadas	BEARING, BUSHING OR THURST WASHER	Part Number	
19	L6 1960-76	225 (3.7L) H225, HA225, HB225, HC225 (3700cc) A100, Aspen, Barracuda, Belvedere, Challenger, Charger, Cordoba, Coronet, Dart, Diplomat, Duster, Fury, Gran Fury, L600, Lancer, Lebaron, Mirada, New Yorker, Newport, P100, P200, P300, P400, Polara, Polara, Ram, S500, Satellite, Savoy, Scamp, Sport Fury, St. Regis, Trailduster, Valiant, Volare, Voyager, W500	86.36 3.400	104.78 4.125	COJINETE DE BIELA	6B606 STD 010 020 030 040	TODOS	
					COJINETE DE BANCADA	4C517 STD 010 020 030 040	1-2-4 (A, B)	
							3 (C, D)	
20	L6 1976-87	225 (3.7L) OHV (3700cc) A100, Aspen, Barracuda, Belvedere, Challenger, Charger, Cordoba, Coronet, Dart, Diplomat, Duster, Fury, Gran Fury, L600, Lancer, Lebaron, Mirada, New Yorker, Newport, P100, P200, P300, P400, Polara, Polara, Ram, S500, Satellite, Savoy, Scamp, Sport Fury, St. Regis, Trailduster, Valiant, Volare, Voyager, W500	86.36 3.400	104.78 4.125	COJINETE DE BIELA	6B1214 STD 010 020 030 040 050	TODOS	
					COJINETE DE BANCADA	4C1419 STD 010 020 030 040	1-2-4 (A, B)	
							3 (C, D)	
					BUJE DE ARBOL	MO1473M STD 010	1	
							2	
		3						
		4						

Diámetro Estándar del Muñón Standard Shaft Diameter	Diámetro Total del Alojamiento Housing Bore	Ancho del Cojinete Width Bearing	Espesor Máximo de Pared Max Wall Thickness	Claro de Lubricación Oil Clearance	Torque Torque	Imagen del Cojinete / Arandela Image of the Bearing and Thrust Washer
55.537/55.563 2.187/2.188	58.738/58.750 2.313/2.313	25.15 0.990	1.585 0.0624	0.0177/0.0711 0.0007/0.0028	61 N.m 45 Lbs.Ft	 12 Piezas
69.837/69.863 2.750/2.751	74.740/74.752 2.943/2.943	26.39 1.039	2.436 0.0959	0.0254/0.1524 0.0010/0.0060	115 N.m 85 Lbs.Ft	 3 Piezas 3 Piezas 1 Pieza 1 Pieza
69.837/69.863 2.750/2.751	74.740/74.752 2.943/2.943	31.88 1.255	2.436 0.0959	0.0127/0.0660 0.0005/0.0026		
55.537/55.563 2.187/2.188	58.738/58.750 2.313/2.313	18.29 0.720	1.582 0.0623	0.0101/0.0736 0.0004/0.0029	61 N.m 45 Lbs.Ft	 12 Piezas
69.837/69.863 2.750/2.751	74.740/74.752 2.943/2.943	22.40 0.882	2.436 0.0959	0.0127/0.0660 0.0005/0.0026	115 N.m 85 Lbs.Ft	 3 Piezas 3 Piezas 1 Pieza 1 Pieza
69.837/69.863 2.750/2.751	74.740/74.752 2.943/2.943	28.14 1.108	2.436 0.0959	0.0127/0.0660 0.0005/0.0026		
50.749/50.775 1.998/1.999	54.089/54.115 2.130/2.131	23.37 0.920	1.638 0.0645	0.0635/0.1651 0.0025/0.0065		1 Pieza
50.343/50.368 1.982/1.983	53.683/53.708 2.114/2.115	19.05 0.750	1.638 0.0645	0.0635/0.1651 0.0025/0.0065		1 Pieza
49.962/49.987 1.967/1.968	53.302/53.327 2.099/2.100	19.05 0.750	1.638 0.0645	0.0635/0.1651 0.0025/0.0065		1 Pieza
49.555/49.581 1.951/1.952	52.896/52.921 2.083/2.084	19.05 0.750	1.638 0.0645	0.0635/0.1651 0.0025/0.0065		1 Pieza

CHRYSLER

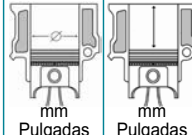
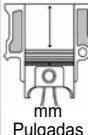
MORESA!

CHRYSLER DODGE JEEP PLYMOUTH

CIL.	AÑO	MOTOR / APLICACIÓN		Diámetro del Cilindro Nominal Bore	Carrera Stroke	COJINETE, BUJE O ARANDELA	No. de Parte	Ubicación Location
CYL.	YEAR	ENGINE / APPLICATION		 mm Pulgadas	 mm Pulgadas	BEARING, BUSHING OR THURST WASHER	Part Number	
21	V6	2002-06 226 (3.7L) EKG SOHC 12 valve (3700 cc) Dakota, Durango, Ram, Liberty		93.00 3.661	90.80 3.574	COJINETE DE BIELA	6B1818 STD 25MM 50MM	TODOS
						COJINETE DE BANCADA	4C2244 STD 25MM 50MM	1-2-3-4 (A, B)
								3 (C, D)
						BUJE DE ARBOL	MO1895M STD	1
22	L6	1965-78 232 (3.8L) AMC OHV (3797 cc) AMX (Javelin), Ambassador, American, Classic, Concord, Gremlin, Hornet, Javelin, Marlin, Matador, Pacer, Rambler, Rebel, Spirit, Typhoon		95.25 3.750	88.90 3.500	COJINETE DE BIELA	6B960 STD 010 020 030 040 050 060	TODOS
		3 (C, D)						
		1971-90 258 (4.2L) AMC OHV (4200 cc) CJ5, CJ6, CJ7, Cherokee, Comanche, Gladiator, Grand Wagoneer, J10, J20, J2500, J2600, J3800, J4500, J4600, J4700, J4800, Jeepster, Scrambler, Wagoneer, Wrangler	95.25 3.750	99.21 3.906	COJINETE DE BANCADA	7C1947 STD 010 020 030	1-2-4-5-6-7 (A, B)	
							3 (C, D)	
		1987-90 258 (4.2L) AMC OHV (4200 cc) CJ5, CJ6, CJ7, Cherokee, Comanche, Gladiator, Grand Wagoneer, J10, J20, J2500, J2600, J3800, J4500, J4600, J4700, J4800, Jeepster, Scrambler, Wagoneer, Wrangler	95.25 3.750	99.21 3.906	COJINETE DE BANCADA	7C1947 STD 010 020 030	1-2-4-5-6-7 (A, B)	
3 (C, D)								
1991-02 258 (4.2L) AMC OHV (4200 cc) CJ5, CJ6, CJ7, Cherokee, Comanche, Gladiator, Grand Wagoneer, J10, J20, J2500, J2600, J3800, J4500, J4600, J4700, J4800, Jeepster, Scrambler, Wagoneer, Wrangler	95.25 3.750	99.21 3.906	COJINETE DE BANCADA 1991-02 258 AMC OHV	7C1947 STD 010 020 030	3 (C, D)			



Diámetro Estándar del Muñón Standard Shaft Diameter	Diámetro Total del Alojamiento Housing Bore	Ancho del Cojinete Width Bearing	Espesor Máximo de Pared Max Wall Thickness	Claro de Lubricación Oil Clearance	Torque Torque	Imagen del Cojinete / Arandela Image of the Bearing and Thrust Washer
57.897/57.904 2.279/2.280	61.194/61.206 2.409/2.410	16.51 0.650	1.626 0.0640	0.0685/0.0685 0.0010/0.0027	27 N.m + 90° 20 Lbs.Ft + 90°	
63.495/63.505 2.500/2.500	68.395/68.405 2.693/2.693	20.62 0.812	2.443 0.0962	0.0050/0.0330 0.0002/0.0013	Paso 1 60 N.m + 90° 44 Lbs.Ft + 90° Paso 2 24 N.m 18 Lbs.Ft	
72.316/72.415 2.847/2.851	92.316/92.415 3.635/3.638		2.550 0.1004			
55.986/56.012 2.204/2.205	59.761/59.789 2.353/2.354	18.16 0.715	1.841 0.0725	0.0660/0.1701 0.0026/0.0067		
28.986/29.012 1.141/1.142	32.761/32.788 1.290/1.291	18.03 0.710	1.854 0.0730	0.0406/0.1447 0.0016/0.0057		
53.208/53.226 2.095/2.096	56.083/56.096 2.208/2.209	21.26 0.837	1.422 0.0560	0.0304/0.0863 0.0012/0.0034	41 N.m 30 Lbs.Ft	
63.470/63.487 2.499/2.500	68.351/68.377 2.691/2.692	25.04 0.986	2.421 0.0953	0.0152/0.0787 0.0006/0.0031	102 a 115 N.m	
63.470/63.487 2.499/2.500	68.351/68.377 2.691/2.692	32.26 1.270	2.421 0.0953	0.0152/0.0787 0.0006/0.0031	75 a 85 Lbs.Ft	
63.470/63.487 2.499/2.500	68.351/68.377 2.691/2.692	25.04 0.986	2.421 0.0953	0.0152/0.0787 0.0006/0.0031	102 a 115 N.m	
63.470/63.487 2.499/2.500	68.351/68.377 2.691/2.692	32.26 1.270	2.421 0.0953	0.0152/0.0787 0.0006/0.0031	75 a 85 Lbs.Ft	

CHRYSLER

MORESA

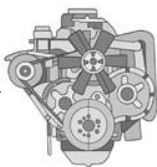
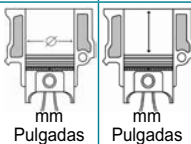
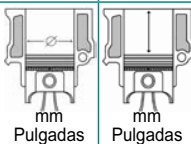
CHRYSLER DODGE JEEP PLYMOUTH

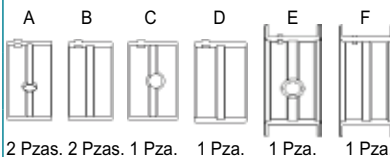

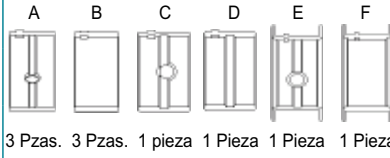
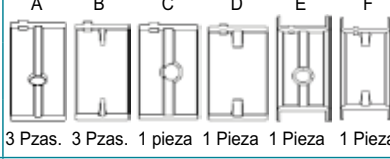
CIL.	AÑO	MOTOR / APLICACIÓN		Diámetro del Cilindro Nominal Bore	Carrera Stroke	COJINETE, BUJE O ARANDELA	No. de Parte	Ubicación Location		
CYL.	YEAR	ENGINE / APPLICATION		mm Pulgadas	mm Pulgadas	BEARING, BUSHING OR THURST WASHER	Part Number	→ 1 2 3 4 5		
23	V6	1987-03 239 (3.9L) OHV Dodge Truck V6 Engine (3900 cc) Dakota, Durango, Ram		99.31 3.910	84.07 3.310	COJINETE DE BIELA	6B1387 STD 010 020 030	TODOS		
						COJINETE DE BANCADA	4C1701 STD 010 020 030	1-3 (A, B)		
								4 (C, D)		
BUJE DE ARBOL	MO1790M STD	1 2 3 4								
24	V8	1964-69 273 (4.5L) OHV (4500cc) A100, Barracuda, Charger, Coronet, Dart, Fury, Satellite, Valiant		92.08 3.625	84.15 3.313	COJINETE DE BIELA	8B481 STD 010 020 030 040	TODOS		
		COJINETE DE BANCADA				5C540 STD 010 020 030 040	1-2-4 (A, B)			
							3 (E, F)			
		1956-57 277 (4.6L) OHV (4550cc) Belvedere, Plaza, Savoy				99.31 3.910	79.38 3.125	COJINETE DE BANCADA	5C1344 STD 010 020 030 040	5 (C, D)
		1957 301 (4.9L) OHV (4900cc) Belvedere, Plaza, Savoy								1-2-4 (A, B)
		1956 303 (5.0L) OHV (5000cc) Belvedere				98.43 3.875	84.15 3.313	COJINETE DE BANCADA	5C1344 STD 010 020 030 040	3 (C, D)
		1957-58 313 (5.1L) OHV (5100cc) 1957-73 318 (5.2L) OHV 1974-03 318 (5.2L) OHV								5 (E, F)
1993-98 318 (5.2L) OHV (5200cc) A100, Barracuda, Belvedere, C500, Challenger, Charger, Coronet, D500, Dart, Duster, Fury, Gran Fury, L600, M300, P300, P400, Plaza, Polara, Ram, Road Runner, S500, S600, Satellite, Savoy, Scamp, Sport Fury, Sport Satellite, VIP, W500	99.36 3.912	84.15 3.313	BUJE DE ARBOL	MO1451M STD 010	1 2 3 4 5					
1959 326 (5.3L) OHV (5300cc) Coronet					1					
					2					





Diámetro Estándar del Muñón Standard Shaft Diameter	Diámetro Total del Alojamiento Housing Bore	Ancho del Cojinete Width Bearing	Espesor Máximo de Pared Max Wall Thickness	Claro de Lubricación Oil Clearance	Torque Torque	Imagen del Cojinete / Arandela Image of the Bearing and Thrust Washer
mm Pulgadas	mm Pulgadas	mm Pulgadas	mm Pulgadas	mm Pulgadas	N.m Lbs.Ft	
53.950/53.975 2.124/2.125	57.150/57.168 2.250/2.251	18.67 0.735	1.585 0.0624	0.0127/0.0558 0.0005/0.0022	61 N.m 45 Lbs.Ft	 12 Piezas
63.487/63.513 2.500/2.501	68.390/68.402 2.693/2.693	22.28 0.877	2.431 0.0957	0.0127/0.0660 0.0005/0.0026	115 N.m 85 Lbs.Ft	 A B C D E F 2 Pzas. 2 Pzas. 1 Pza. 1 Pza. 1 Pza. 1 Pza.
63.487/63.513 2.500/2.501	68.390/68.402 2.693/2.693	33.71 1.327	2.431 0.0957	0.0127/0.0660 0.0005/0.0026		
63.487/63.513 2.500/2.501	68.390/68.402 2.693/2.693	29.26 1.152	2.431 0.0957	0.0127/0.0660 0.0005/0.0026		1 Pieza
50.749/50.775 1.998/1.999	54.089/54.115 2.130/2.131	21.97 0.865	1.638 0.0645	0.0381/0.1397 0.0015/0.0055		1 Pieza
50.343/50.368 1.982/1.983	53.683/53.708 2.114/2.115	15.88 0.625	1.638 0.0645	0.0381/0.1397 0.0015/0.0055		1 Pieza
49.555/49.581 1.951/1.952	52.896/52.921 2.083/2.084	15.62 0.615	1.638 0.0645	0.0381/0.1397 0.0015/0.0055		1 Pieza
39.637/39.662 1.561/1.562	42.977/43.002 1.692/1.693	23.88 0.940	1.638 0.0645	0.0127/0.1143 0.0005/0.0045		1 Pieza
53.950/53.975 2.124/2.125	57.150/57.168 2.250/2.250	21.53 0.848	1.585 0.0624	0.0177/0.0812 0.0007/0.0032	61 a 68 N.m 45 a 50 Lbs.Ft	 16 Piezas
63.487/63.513 2.499/2.500	68.390/68.402 2.693/2.693	22.28 0.877	2.431 0.0957	0.0127/0.0660 0.0005/0.0026	108 a 115 N.m 80 a 85 Lbs.Ft	 A B C D E F 3 Pzas. 3 Pzas. 1 pieza 1 Pieza 1 Pieza 1 Pieza
63.487/63.513 2.499/2.500	68.390/68.402 2.693/2.693	29.26 1.152	2.431 0.0957	0.0127/0.0660 0.0005/0.0026		
63.487/63.513 2.499/2.500	68.390/68.402 2.693/2.693	33.71 1.327	2.431 0.0957	0.0127/0.0660 0.0005/0.0026		1 Pieza
63.487/63.513 2.500/2.501	68.390/68.402 2.693/2.693	22.28 0.877	2.431 0.0957	0.0127/0.0660 0.0005/0.0026	115 N.m 85 Lbs.Ft	 A B C D E F 3 Pzas. 3 Pzas. 1 pieza 1 Pieza 1 Pieza 1 Pieza
63.487/63.513 2.500/2.501	68.390/68.402 2.693/2.693	29.26 1.152	2.431 0.0957	0.0101/0.0635 0.0004/0.0025		
63.487/63.513 2.500/2.501	68.390/68.402 2.693/2.693	33.71 1.327	2.431 0.0957	0.0127/0.0660 0.0005/0.0026		1 Pieza
50.749/50.775 1.998/1.999	54.089/54.115 2.130/2.131	21.97 0.865	1.638 0.0645	0.0381/0.1397 0.0015/0.0055		1 Pieza
50.343/50.368 1.982/1.983	53.683/53.708 2.114/2.115	19.30 0.760	1.638 0.0645	0.0127/0.1143 0.0005/0.0045		1 Pieza
49.962/49.987 1.967/1.968	53.302/53.327 2.099/2.100	19.30 0.760	1.638 0.0645	0.0127/0.1143 0.0005/0.0045		1 Pieza
49.555/49.581 1.951/1.952	52.896/52.921 2.083/2.084	19.30 0.760	1.638 0.0645	0.0127/0.1143 0.0005/0.0045		1 Pieza
39.637/39.662 1.561/1.562	42.977/43.002 1.692/1.693	23.88 0.940	1.638 0.0645	0.0127/0.1143 0.0005/0.0045		1 Pieza

CHRYSLER

MORESA

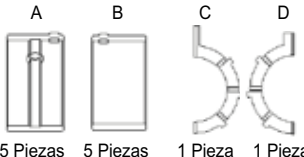
CHRYSLER DODGE JEEP PLYMOUTH

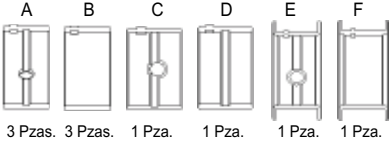
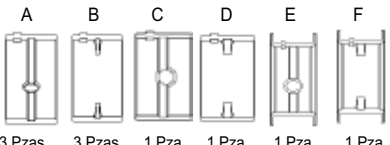
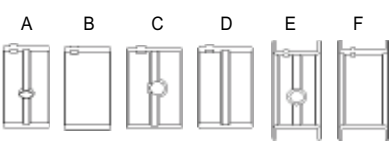
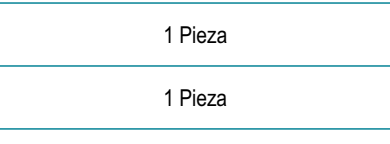
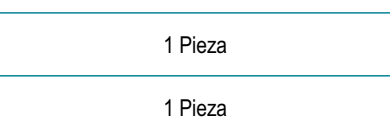

CIL.	AÑO	MOTOR / APLICACIÓN		Diámetro del Cilindro Nominal Bore	Carrera Stroke	COJINETE, BUJE O ARANDELA	No. de Parte	Ubicación Location
CYL.	YEAR	ENGINE / APPLICATION		mm Pulgadas	mm Pulgadas	BEARING, BUSHING OR THURST WASHER	Part Number	
25	V8	1999-05 287 (4.7L) SOHC 16 valve (4700cc) Dakota, Durango, Ram		92.99 3.661	86.51 3.406	COJINETE DE BIELA	8B1784 STD 010 020	TODOS
						COJINETE DE BANCADA	5C2216 STD 010 020	1-2-3-4-5 (A, B) 3 (C, D)
26	V8	1968-73 340 (5.7L) OHV (5650cc) Barracuda, Challenger, Charger, Coronet, Dart, Duster, Fury, Road Runner, Satellite, Sport Fury		102.062 4.040	84.15 3.313	COJINETE DE BIELA	8B481 STD 010 020 030 040	TODOS
						COJINETE DE BANCADA	5C540 STD 010 020 030 040	1-2-4 (A, B)
								3 (E, F)
						COJINETE DE BANCADA	5C1344 STD 010 020 030 040	5 (C, D)
								1-2-4 (A, B)
3 (E, F)								
COJINETE DE BANCADA	5C963 STD 010 020 030	1-2-4 (A, B)						
3 (E, F)								
5 (C, D)								
BUJE DE ARBOL	MO1451M STD 010	1						
2								
3								
4								
5								





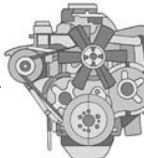
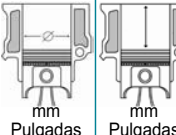
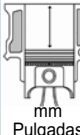

Diámetro Estándar del Muñón Standard Shaft Diameter	Diámetro Total del Alojamiento Housing Bore	Ancho del Cojinete Width Bearing	Espesor Máximo de Pared Max Wall Thickness	Claro de Lubricación Oil Clearance	Torque	Imagen del Cojinete / Arandela Image of the Bearing and Thrust Washer
mm Pulgadas	mm Pulgadas	mm Pulgadas	mm Pulgadas	mm Pulgadas	N.m Lbs.Ft	
50.996/51.003 2.008/2.008	53.993/54.005 2.126/2.126	16.64 0.655	1.491 0.0587	0.0203/0.0635 0.0008/0.0025	27 N.m + 90° 20 Lbs.Ft + 90°	 16 Piezas
63.495/63.505 2.500/2.500	68.395/68.405 2.693/2.693	20.62 0.812	2.443 0.0962	0.0050/0.0330 0.0002/0.0013	Interno 34 N.m + 90° 25 Lbs.Ft + 90° Externo 54 N.m 40 Lbs.Ft	 5 Piezas 5 Piezas 1 Pieza 1 Pieza
72.316/72.415 2.847/2.851	92.316/92.415 3.635/3.638		2.550 0.1004			
53.950/53.975 2.1240/2.1250	57.150/57.168 2.2500/2.2505	21.53 0.848	1.585 0.0624	0.0177/0.0812 0.0007/0.0032	61 a 68 N.m 45 a 50 Lbs.Ft	 16 Piezas
63.487/63.513 2.4995/2.5000	68.390/68.402 2.6925/2.6929	22.28 0.877	2.431 0.0957	0.0127/0.0660 0.0005/0.0026	109 a 115 N.m	 3 Pzas. 3 Pzas. 1 Pza. 1 Pza. 1 Pza. 1 Pza.
63.487/63.513 2.4995/2.5000	68.390/68.402 2.6925/2.6929	29.26 1.152	2.431 0.0957	0.0127/0.0660 0.0005/0.0026	80 a 85 Lbs.Ft	 3 Pzas. 3 Pzas. 1 Pza. 1 Pza. 1 Pza. 1 Pza.
63.487/63.513 2.500/2.501	68.390/68.402 2.693/2.693	22.28 0.877	2.431 0.0957	0.0127/0.0660 0.0005/0.0026	115 N.m	 3 Pzas. 3 Pzas. 1 Pza. 1 Pza. 1 Pza. 1 Pza.
63.487/63.513 2.500/2.501	68.390/68.402 2.693/2.693	29.26 1.152	2.431 0.0957	0.0101/0.0635 0.0004/0.0025	85 Lbs.Ft	 3 Pzas. 3 Pzas. 1 Pza. 1 Pza. 1 Pza. 1 Pza.
63.487/63.513 2.4995/2.5000	68.390/68.402 2.6925/2.6929	22.28 0.877	2.431 0.0957	0.0127/0.0660 0.0005/0.0026	115 N.m	 3 Pzas. 3 Pzas. 1 Pza. 1 Pza. 1 Pza. 1 Pza.
63.487/63.513 2.4995/2.5000	68.390/68.402 2.6925/2.6929	33.71 1.327	2.431 0.0957	0.0127/0.0660 0.0005/0.0026	85 Lbs.Ft	 3 Pzas. 3 Pzas. 1 Pza. 1 Pza. 1 Pza. 1 Pza.
63.487/63.513 2.4995/2.5000	68.390/68.402 2.6925/2.6929	29.26 1.152	2.431 0.957	0.0127/0.0660 0.0005/0.0026		1 Pieza
50.749/50.775 1.998/1.999	54.089/54.115 2.130/2.131	21.97 0.865	1.638 0.0645	0.0381/0.1397 0.0015/0.0055		1 Pieza
50.343/50.368 1.982/1.983	53.683/53.708 2.114/2.115	19.30 0.760	1.638 0.0645	0.0127/0.1143 0.0005/0.0045		1 Pieza
49.962/49.987 1.967/1.968	53.302/53.327 2.099/2.100	19.30 0.760	1.638 0.0645	0.0127/0.1143 0.0005/0.0045		1 Pieza
49.555/49.581 1.951/1.952	52.896/52.921 2.083/2.084	19.30 0.760	1.638 0.0645	0.0127/0.1143 0.0005/0.0045		1 Pieza
39.637/39.662 1.561/1.562	42.977/43.002 1.692/1.693	23.88 0.940	1.638 0.0645	0.0127/0.1143 0.0005/0.0045		1 Pieza

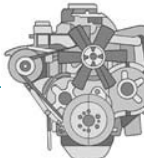
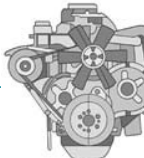
CHRYSLER

MORESA!

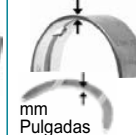
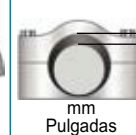
CHRYSLER DODGE JEEP PLYMOUTH

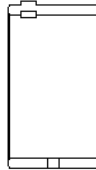
CIL.	AÑO	MOTOR / APLICACIÓN		Diámetro del Cilindro Nominal Bore	Carrera Stroke	COJINETE, BUJE O ARANDELA	No. de Parte	Ubicación Location
CYL.	YEAR	ENGINE / APPLICATION		 mm Pulgadas	 mm Pulgadas	BEARING, BUSHING OR THURST WASHER	Part Number	
27	V8	1968-71 350 (5.7L) Buick OHV (5718 cc) Gladiator, J2500, J3800, J4500, J4600, J4700, J4800, Jeepstep, Wagoneer		96.52 3.800	97.79 3.850	COJINETE DE BIELA	8B610 STD 010 020	TODOS
28	V8	1958 350 (5.7L) OHV (5736 cc) Belvedere, Firesweep, Royal		103.20 4.063	85.73 3.375	COJINETE DE BIELA	8B527 STD 010 020 030 040	TODOS
		1958-77 361 (5.9L) OHV (5900 cc) Belvedere, C500, C800, CT700, CT800, Charger, Coronet, Custom Royal, Dart, DeSoto, Firedome, Fireflite, Firesweep, Fury, Matador, Newport, Polara, Royal, Savoy		104.90 4.125	85.73 3.375			
		1966-67 361.1 (5.9L) OHV (5900 cc) L600, L700, VIP		104.78 4.125	85.73 3.375	COJINETE DE BANCADA	5C876 STD 010 020 030	1-2-4-5 (A, B)
		1961-71 383 (6.3L) OHV (6277 cc) Barracuda, Belvedere, Challenger, Charger, Coronet, Dart, Firedome, Fireflite, Fury, Matador, Monaco, Newport, Polara, Ram, Road Runner, Satellite, Sport Satellite, VIP		107.95 4.250	85.73 3.375			
		1972-80 400 (6.6L) OHV (6600 cc) Brougham, Charger, Cordoba, Coronet, Fury, Gran Fury, Magnum, Monaco, New Yorker, Newport, Ram, Road Runner, Satellite, Sport Fury, Trailduster, Voyager		110.29 4.342	85.73 3.375			

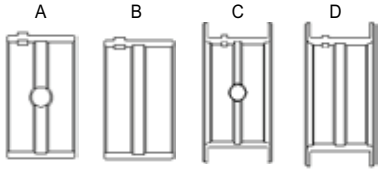
Diámetro Estándar del Muñón Standard Shaft Diameter	Diámetro Total del Alojamiento Housing Bore	Ancho del Cojinete Width Bearing	Espesor Máximo de Pared Max Wall Thickness	Claro de Lubricación Oil Clearance	Torque Torque	Imagen del Cojinete / Arandela Image of the Bearing and Thrust Washer
						
50.787/50.813 2.000/2.001	53.967/53.980 2.125/2.125	18.85 0.742	1.575 0.0620	0.0177/0.0812 0.0007/0.0032	54 a 61 N.m 40 a 45 Lbs.Ft	 16 Piezas
60.300/60.325 2.374/2.375	63.500/63.513 2.500/2.501	23.67 0.932	1.582 0.0623	0.0228/0.0863 0.0009/0.0034	68 N.m 45 Lbs.Ft	 16 Piezas
66.662/66.688 2.625/2.626	71.565/71.577 2.818/2.818	24.10 0.949	2.428 0.0956	0.0279/0.0914 0.0011/0.0036	115 N.m 85 Lbs.Ft	 4 Piezas 4 Piezas 1 Pieza 1 Pieza
66.662/66.688 2.625/2.626	71.565/71.577 2.818/2.818	31.09 1.224	2.428 0.0956	0.0279/0.0914 0.0011/0.0036		

CHRYSLER





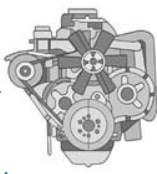

MORESA!

CHRYSLER DODGE JEEP PLYMOUTH

CIL.	AÑO	MOTOR / APLICACIÓN		Diámetro del Cilindro Nominal Bore	Carrera Stroke	COJINETE, BUJE O ARANDELA	No. de Parte	Ubicación Location
CYL.	YEAR	ENGINE / APPLICATION		mm Pulgadas	mm Pulgadas	BEARING, BUSHING OR THURST WASHER	Part Number	→ 1 2 3 4 5
V8	1971-03	360 (5.9L) OHV (5891cc)	101.60	90.88	COJINETE DE BIELA	8B481 STD 010 020 030 040	→ 1 2 3 4 5	
	1974-01	360 (5.9L) OHV (5891cc) Aspen, Barracuda, Brougham, Caravelle, Challenger, Charger, Cordoba, Coronet, D500, D600, Dakota, Dart, Diplomat, Durango, Duster, Fury, Gran Fury, M300, Magnum, Mirada, Monaco, Newport, Polara, Ram, Ramcharger, Road Runner, Royal Monaco, Satellite, Scamp, Sport Fury, St. Regis, Trailduster, Valiant, Volare, Voyager	4.000	3.578				TODOS
	1971-73	360 (5.9L) OHV (5891cc) Aspen, Barracuda, Brougham, Caravelle, Challenger, Charger, Cordoba, Coronet, D500, D600, Dakota, Dart, Diplomat, Durango, Duster, Fury, Gran Fury, M300, Magnum, Mirada, Monaco, Newport, Polara, Ram, Ramcharger, Road Runner, Royal Monaco, Satellite, Scamp, Sport Fury, St. Regis, Trailduster, Valiant, Volare, Voyager	101.60 4.000	90.88 3.578	COJINETE DE BANCADA 1971-73 360 OHV	5C1051 STD 010 020 030 040	1-2-4 (A, B)	
						3 (E, F)		
						5 (C, D)		
	1974-01	360 (5.9L) Chrysler OHV (5891cc) Aspen, Barracuda, Brougham, Caravelle, Challenger, Charger, Cordoba, Coronet, D500, D600, Dakota, Dart, Diplomat, Durango, Duster, Fury, Gran Fury, M300, Magnum, Mirada, Monaco, Newport, Polara, Ram, Ramcharger, Road Runner, Royal Monaco, Satellite, Scamp, Sport Fury, St. Regis, Trailduster, Valiant, Volare, Voyager	101.60 4.000	90.88 3.578	COJINETE DE BANCADA 1974-2001 360 Chrysler OHV	5C1266 STD 010 020 030 040	1-2-4 (A, B)	
						3 (E, F)		
						5 (C, D)		
	1971-78	360 (5.9L) OHV (5891cc) Aspen, Barracuda, Brougham, Caravelle, Challenger, Charger, Cordoba, Coronet, D500, D600, Dakota, Dart, Diplomat, Durango, Duster, Fury, Gran Fury, M300, Magnum, Mirada, Monaco, Newport, Polara, Ram, Ramcharger, Road Runner, Royal Monaco, Satellite, Scamp, Sport Fury, St. Regis, Trailduster, Valiant, Volare, Voyager	101.60 4.000	90.88 3.578	BUJE DE ARBOL 1971-78 360 OHV	MO1451M STD 010	1	
						2		
						3		
						4		
5								
1979-99	360 (5.9L) OHV (5891cc) Aspen, Barracuda, Brougham, Caravelle, Challenger, Charger, Cordoba, Coronet, D500, D600, Dakota, Dart, Diplomat, Durango, Duster, Fury, Gran Fury, M300, Magnum, Mirada, Monaco, Newport, Polara, Ram, Ramcharger, Road Runner, Royal Monaco, Satellite, Scamp, Sport Fury, St. Regis, Trailduster, Valiant, Volare, Voyager	101.60 4.000	90.88 3.578	BUJE DE ARBOL 1979-99 360 OHV	MO1484M STD 010	1		
					2			
					3			
					4			
					5			

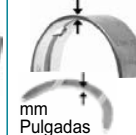
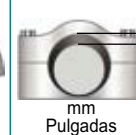
Línea Line

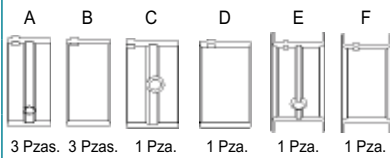
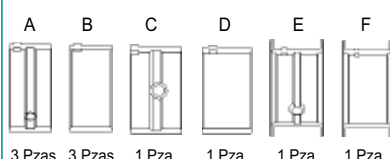

29

Diámetro Estándar del Muñón Standard Shaft Diameter	Diámetro Total del Alojamiento Housing Bore	Ancho del Cojinete Width Bearing	Espesor Máximo de Pared Max Wall Thickness	Claro de Lubricación Oil Clearance	Torque Torque	Imagen del Cojinete / Arandela Image of the Bearing and Thrust Washer
						
53.950/53.975 2.124/2.125	57.150/57.168 2.250/2.251	21.53 0.848	1.585 0.0624	0.0177/0.0812 0.0007/0.0032	61 a 68 N.m 45 a 50 Lbs.Ft	 16 Piezas
71.361/71.387 2.810/2.811	76.264/76.276 3.003/3.003	22.28 0.877	2.436 0.0959	0.0127/0.0812 0.0005/0.0032	115 N.m 85 Lbs.Ft	 A B C D E F 3 Pzas. 3 Pzas. 1 Pza. 1 Pza. 1 Pza. 1 Pza.
71.361/71.387 2.810/2.811	76.264/76.276 3.003/3.003	29.26 1.152	2.436 0.0959	0.0127/0.0812 0.0005/0.0032		
71.361/71.387 2.810/2.811	76.264/76.276 3.003/3.003	31.98 1.259	2.436 0.0959	0.0127/0.0812 0.0005/0.0032		
71.361/71.387 2.810/2.811	76.264/76.276 3.003/3.003	22.28 0.877	2.436 0.0959	0.0127/0.0812 0.0005/0.0032	115 N.m 85 Lbs.Ft	 A B C D E F 3 Pzas. 3 Pzas. 1 Pza. 1 Pza. 1 Pza. 1 Pza.
71.361/71.387 2.810/2.811	76.264/76.276 3.003/3.003	29.26 1.152	2.436 0.0959	0.0127/0.0812 0.0005/0.0032		
71.361/71.387 2.810/2.811	76.264/76.276 3.003/3.003	31.98 1.259	2.436 0.0959	0.0127/0.0812 0.0005/0.0032		
50.749/50.775 1.998/1.999	54.089/54.115 2.130/2.131	21.97 0.865	1.638 0.0645	0.0381/0.1397 0.0015/0.0055		1 Pieza
50.343/50.368 1.982/1.983	53.683/53.708 2.114/2.115	19.30 0.760	1.638 0.0645	0.0127/0.1143 0.0005/0.0045		1 Pieza
49.962/49.987 1.967/1.968	53.302/53.327 2.099/2.100	19.30 0.760	1.638 0.0645	0.0127/0.1143 0.0005/0.0045		1 Pieza
49.555/49.581 1.951/1.952	52.896/52.921 2.083/2.084	19.30 0.760	1.638 0.0645	0.0127/0.1143 0.0005/0.0045		1 Pieza
39.637/39.662 1.561/1.562	42.977/43.002 1.692/1.693	23.88 0.940	1.638 0.0645	0.0127/0.1143 0.0005/0.0045		1 Pieza
50.749/50.775 1.998/1.999	54.089/54.115 2.130/2.131	21.97 0.865	1.638 0.0645	0.0381/0.1397 0.0015/0.0055		1 Pieza
50.343/50.368 1.982/1.983	53.683/53.708 2.114/2.115	19.30 0.760	1.638 0.0645	0.0381/0.1397 0.0015/0.0055		1 Pieza
49.962/49.987 1.967/1.968	53.302/ 53.327 2.099/ 2.100	19.30 0.760	1.638 0.0645	0.0381/0.1397 0.0015/0.0055		1 Pieza
49.555/49.581 1.951/1.952	52.896/52.921 2.083/2.084	19.30 0.760	1.638 0.0645	0.0381/0.1397 0.0015/0.0055		1 Pieza
39.637/39.662 1.561/1.562	42.977/43.002 1.692/1.693	23.88 0.940	1.638 0.0645	0.0127/0.1143 0.0005/0.0045		1 Pieza





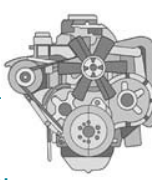
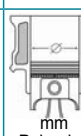
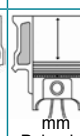

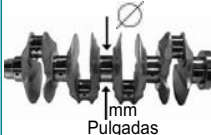

CHRYSLER

MORESA

CHRYSLER DODGE JEEP PLYMOUTH

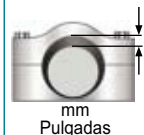
CIL.	AÑO	MOTOR / APLICACIÓN			Diámetro del Cilindro Nominal Bore	Carrera Stroke	COJINETE, BUJE O ARANDELA	No. de Parte	Ubicación Location
CYL.	YEAR	ENGINE / APPLICATION	 mm Pulgadas	 mm Pulgadas			BEARING, BUSHING OR THURST WASHER	Part Number	
V8	1959-60	383 (6.3L) OHV (6300 cc) Barracuda, Belvedere, Challenger, Charger, Coronet, Dart, Firedome, Fireflite, Fury, Matador, Monaco, Newport, Polara, Ram, Road Runner, Satellite, Sport Satellite, VIP	102.39 4.031	95.25 3.750					
	1959-77	413 (6.8L) OHV (6800 cc) Belvedere, Coronet, Fury, Monaco, Polaro, Sport Fury	106.38 4.188	95.25 3.750					
	1960-77	413 (6.8L) OHV HT413 (6800 cc) New Yorker, Polara, Savoy	106.38 4.188	95.25 3.750					
	1963-65	426 (7.0L) OHV Wedge(7000 cc) Belvedere, Coronet, Fury, Monaco, Polara, Savoy, Sport Fury	107.95 4.250	95.25 3.750					
	1964-71	426 (7.0L) HEMI (7000 cc) Barracuda, Belvedere, Challenger, Charger, Coronet, Fury, GTX, Road Runner, Satellite, Savoy, Sport Fury	107.95 4.250	95.25 3.750	COJINETE DE BIELA	8B527 STD 010 020 030 040	TODOS		
	1966-80	440 (7.2L) OHV (7200 cc) Barracuda, Belvedere, Challenger, Charger, Coronet, Crown, Fury, GTX, Gran Fury, Imperial, Lebaron, M300, Monaco, New Yorker, Newport, Polara, Ram, Road Runner, Royal Monaco, Satellite, Sport Fury, Sport Satellite, Trailduster, VIP, Voyager	109.72 4.320	95.25 3.750					
	1972-80	440-3 (7.2L) OHV (7202 cc) 100 Series (1/2 Ton), 150 Series (1/2 Ton), 200 Series (3/4 Ton), 250 Series (3/4 Ton), 300 Series (1 Ton), 350 Series (1 Ton)	109.72 4.320	95.25 3.750					

Línea Line
30

Diámetro Estándar del Muñón Standard Shaft Diameter	Diámetro Total del Alojamiento Housing Bore	Ancho del Cojinete Width Bearing	Espesor Máximo de Pared Max Wall Thickness	Claro de Lubricación Oil Clearance	Torque Torque	Imagen del Cojinete / Arandela Image of the Bearing and Thrust Washer
 mm Pulgadas	 mm Pulgadas	 mm Pulgadas	 mm Pulgadas	 mm Pulgadas	 N.m Lbs.Ft	
60.300/60.325 2.374/2.375	63.500/63.513 2.500/2.501	23.67 0.932	1.582 0.0623	0.0228/0.0863 0.0009/0.0034	61 N.m 45 Lbs.Ft	 16 Piezas

FORD LINCOLN MERCURY

4 CILINDROS / 4 CYLINDER		
MOTOR / ENGINE	AÑO / YEAR	LINEA / LINE
1.3 L, (1.3L) HSC	1998-02	1
81 (1.3L) Mazda SOHC 8 valve	1988-97	2
1.4 L, (1.4L) HSC	1998-04	1
1.6 L (1.6L) HSC, Zetec Rocam ZL	1998-04	1
98 (1.6L) Mazda SOHC 8 valve	1987-89	2
98 (1.6L) Mazda DOHC 16 valve	1990-94	2
98 (1.6L) Mazda Turbo DOHC 16 valve	1990-94	2
112 (1.8L) Mazda DOHC 16 valve	1991-96	2
110 (1.8L) Mazda VB SOHC 8 valve	1972-78	3
116 (1.9L) SOHC 8 valve	1985-96	4
121 (2.0L) Mazda MB SOHC 8 valve	1979-82	3
121 (2.0L) SOHC 8 valve	1997-04	4
Zetec NGA (2.0L) DOHC 16 Valve ZH20 Zetec E	1996-	5
122 Zetec (2.0L) DOHC 16 valve	1996-04	5
122 (2.0L) Mazda Diesel SOHC 8 valve	1984-87	6
122 (2.0L) SOHC 8 valve	1983-88	7
133 (2.2L) Mazda SOHC 12 valve	1989-92	8
133 (2.2L) Mazda Turbo SOHC 12 valve	1989-92	8
140 (2.3L) SOHC 8 valve	1974-97	7
140 (2.3L) Turbo SOHC 8 valve	1979-90	7
140 (2.3L) HSC OHV	1984-85	9
140 (2.3L) HSC OHV	1984-94	9
153 (2.5L) HSC OHV	1986-91	9
153 (2.5L) SOHC 8 valve	1998-01	7

6 CILINDROS / 6 CYLINDER		
MOTOR / ENGINE	AÑO / YEAR	LINEA / LINE
144 (2.4L) OHV	1960-64	10
155 (2.5L) Duratec DOHC 24 valve	1995-02	11
159 (2.6L) OHV	1972-73	12
170 (2.8L) OHV	1961-72	10
171 (2.8L) OHV	1974-79	13
171 (2.8L) OHV	1983-86	13
171 (2.8L) OHV	1983-86	13
181 (3.0L) Duratec DOHC 24 valve	1996-06	11
181 (3.0L) Nissan SOHC 12 valve	1993-98	14
183 (3.0L) OHV exc. SHO eng.	1986-06	15
199.8 (3.3L) Nissan SOHC 12 valve	1999-02	14
200 (3.3L) OHV	1963-64	10
200 (3.3L) OHV	1965-83	16
232 (3.8L) OHV	1982-04	17
232 (3.8L) Supercharged OHV	1989-95	17
238 (3.9L) OHV	2004	17
240 (3.9L) OHV	1965-74	18
244 (4.0L) OHV	1990-00	19
244 (4.0L) SOHC 12 valve	1997-01	19
244 (4.0L) Flex Fuel SOHC 12 valve	2002-03	19
250 (4.1L) OHV	1969-80	20
256 (4.2L) OHV	1997-06	21
300 (4.9L) OHV	1965-96	22

FORD LINCOLN MERCURY



8 CILINDROS / 8 CYLINDER		
MOTOR / ENGINE	AÑO / YEAR	LINEA / LINE
221 (3.7L) OHV	1962-63	23
239 (3.9L) OHV	1954-55	24
256 (4.1L) OHV	1954-55	24
255 (4.2L) OHV	1980-82	23
260 (4.3L) OHV	1962-65	23
272 (4.5L) OHV	1955-58	24
281 (4.6L) SOHC 16 valve	1991-05	25
281 (4.6L) SOHC CNG 16 valve	1995-03	25
281 (4.6L) SOHC LPG 16 valve	1997-98	25
281 (4.6L) DOHC 32 valve (Triton)	1993-04	25
281 (4.6L) DOHC 32 valve Supercharged / Intercooled (Triton)	2003-04	25
289 (4.7L) OHV exc. Vin "K" and w/ A4 trans.	1965-68	23
289 (4.7L) OHV w/ A4 trans	1963-64	23
289 (4.7L) OHV w/ Vin "K"	1963-68	23
292 (4.8L) OHV	1955-64	24
302 (4.9L) OHV w/ Boss and Eliminator engs.	1969-71	23
302 (5.0L) OHV exc. Boss and Eliminator engs.	1968-01	23
302 (5.0L) High Output OHV exc. Boss and Eliminator engs.	1982-95	23
312 (5.1L) OHV	1956-60	24
330 (5.4L) SOHC 16 valve (Triton)	1997-05	26
330 (5.4L) SOHC CNG 16 valve (Triton)	1997-05	26
330 (5.4L) SOHC Supercharged 16 valve (Triton)	1999-05	26
330 (5.4L) SOHC Bi-Fuel 16 valve (Triton)	1998-05	26
330 (5.4L) OHV	1964-78	27
332 (5.4L) OHV	1958-59	27
335 (5.5L) MÉXICO	1969-86	28
352 (5.7L) OHV	1964-67	27
352 (5.8L) OHV	1958-63	27
361 (5.9L) OHV	1964-78	27
361 (5.9L) OHV	1958-59	27
390 (6.4L) OHV	1961-63	27
390 (6.4L) OHV	1964-76	27
391 (6.4L) OHV	1964-78	27
351W (5.8L)	1969-99	28
351M (5.8L) OHV	1975-82	29
359 (5.9L) OHV	1973-78	30
370 (6.1L) OHV	1979-91	31
400 (6.6L) OHV	1971-82	29
410 (6.7L) OHV	1966-67	30
427 (7.0L) OHV	1968	30
428 (7.0L) OHV	1975-78	30
428 (7.0L) OHV	1966-70	30
429 (7.0L) OHV Truck	1979-98	31
429 (7.0L) OHV Pass.	1968-73	31
460 (7.5L) OHV	1968-98	31



10 CILINDROS / 10 CYLINDER		
MOTOR / ENGINE	AÑO / YEAR	LINEA / LINE
415 (6.8L) SOHC 20 valve (Triton)	1997-06	32

FORD

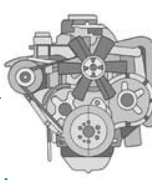
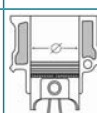
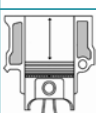
MORESA!

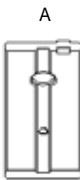
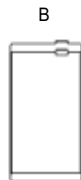

FORD LINCOLN MERCURY

CIL.	AÑO	MOTOR / APLICACIÓN		Diámetro del Cilindro Nominal Bore	Carrera Stroke	COJINETE, BUJE O ARANDELA	No. de Parte	Ubicación Location
CYL.	YEAR	ENGINE / APPLICATION		 mm Pulgadas	 mm Pulgadas	BEARING, BUSHING OR THURST WASHER	Part Number	
1	L4							
	1998-02	1.3 L, (1.3L) HSC (1297 cc) Fiesta	74.00 2.911	75.50 2.972	COJINETE DE BIELA	4B7001 STD 25MM 50MM	TODOS	
	1998-04	1.4 L, (1.4L) HSC (1400 cc) Fiesta						
	1998-04	1.6 L (1.6L) HSC, Zetec Rocam ZL (1600 cc) Fiesta, Ka Courier, Ikon	82.07 3.231	75.48 2.972	COJINETE DE BANCADA	5C7003 STD 25MM 50MM	1-2-3-4-5 (A, B)	
					ARANDELA	AM7002 STD	3	
					BUJE DE ARBOL Motor ingles. (hasta 2002) Cabeza de hierro	MO1459M STD	1 2 3	
				FECHA AUXILIAR Motor ingles. (hasta 2002) Cabeza de hierro	MO1731M STD	1		
2	L4							
	1988-97	81 (1.3L) Mazda SOHC 8 valve (1300 cc) Aspire, Festiva	71.00 2.795	84.00 3.291				
	1987-89	98 (1.6L) Mazda SOHC 8 valve						
	1990-94	98 (1.6L) Mazda DOHC 16 valve	78.00 3.071	84.00 3.291	COJINETE DE BIELA	4B1279 STD 010 020 030	TODOS	
	1990-94	98 (1.6L) Mazda Turbo DOHC 16 valve (1600 cc) Tracer, Capri						
	1991-96	112 (1.8L) Mazda DOHC 16 valve (1800 cc) Escort, Tracer	83.00 3.268	85.00 3.397				

Diámetro Estándar del Muñón Standard Shaft Diameter	Diámetro Total del Alojamiento Housing Bore	Ancho del Cojinete Width Bearing	Espesor Máximo de Pared Max Wall Thickness	Claro de Lubricación Oil Clearance	Torque Torque	Imagen del Cojinete / Arandela Image of the Bearing and Thrust Washer
mm Pulgadas	mm Pulgadas	mm Pulgadas	mm Pulgadas	mm Pulgadas	N.m Lbs.Ft	
40.991/41.011 1.614/1.615	43.990/44.011 1.732/1.733	17.95 0.707	1.473 0.058	0.0228/0.1168 0.0009/0.0046	41 N.m + 90° 30 Lbs.Ft + 90°	 8 Piezas
56.989/57.000 2.243/2.244	60.622/60.634 2.386/2.387	18.39 0.724	1.806 0.0711	0.0152/0.0584 0.0006/0.0023	56 N.m 74 Lbs.Ft	 A  B 4 Piezas 4 Piezas
63.600/63.850 2.504/2.513	77.850/78.100 3.065/3.075		2.819 0.1110			2 Piezas
39.614/39.637 1.560/1.561	42.837/42.913 1.688/1.689	20.07 0.790	1.621 0.0638	0.0254/0.1016 0.0010/0.0040		1 Pieza
39.613/39.637 1.560/1.561	42.837/42.913 1.688/1.689	17.52 0.690	1.621 0.0638	0.0254/0.1016 0.0010/0.0040		1 Pieza
39.613/39.637 1.560/1.561	42.837/42.913 1.688/1.689	20.07 0.790	1.621 0.0638	0.0254/0.1016 0.0010/0.0040		1 Pieza
41.953/41.978 1.652/1.653	45.0723/45.098 1.775/1.776	12.95 0.510	1.5722 0.0619	0.0152/0.0812 0.0006/0.0032		1 Pieza
39.939/39.954 1.572/1.573	43.000/43.015 1.693/1.694	16.99 0.669	1.509 0.0594	0.0254/0.0787 0.0010/0.0031	30 a 34 N.m 22 a 25 Lbs.Ft	 8 Piezas

FORD

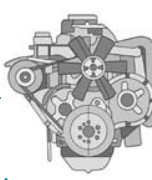
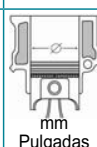
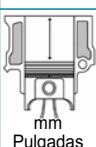
MORESA!













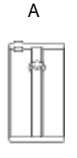

CIL.	AÑO	MOTOR / APLICACIÓN		Diámetro del Cilindro Nominal Bore	Carrera Stroke	COJINETE, BUJE O ARANDELA	No. de Parte	Ubicación Location
CYL.	YEAR	ENGINE / APPLICATION		 mm Pulgadas	 mm Pulgadas	BEARING, BUSHING OR THURST WASHER	Part Number	
L4	1972-78	110 (1.8L) Mazda VB SOHC 8 valve (1800 cc) Courier	77.98 3.070	93.98 3.700	COJINETE DE BIELA	4B1110 STD 010 020 030	TODOS	
	1979-82	121 (2.0L) Mazda MB SOHC 8 valve (2000cc) Courier	80.01 3.150	97.99 3.858				COJINETE DE BANCADA
						ARANDELA	AM231 STD	5
L4	1985-96	116 (1.9L) SOHC 8 valve (1900 cc) EXP, Escort, Lynx, Tracer	81.99 3.228	87.88 3.460	COJINETE DE BIELA	4B1380 STD 010 020 030 040	TODOS	
	1997-04	121 (2.0L) SOHC 8 valve (2000 cc) Escort, Focus, Tracer	84.84 3.340	87.88 3.460				COJINETE DE BANCADA
L4	1996-	Zetec NGA (2.0L) DOHC 16 Valve ZH20 Zetec E (1988 cc)	84.80 3.339	88.00 3.465	COJINETE DE BIELA	4B4121 STD 010 020 030	TODOS	
	1996-04	122 Zetec (2.0L) DOHC 16 valve (1989 cc) Contour, Escape, Focus, Mystique.	84.80 3.339	88.00 3.465				COJINETE DE BANCADA

Línea Line

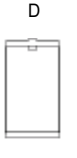
3

4

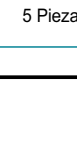

5

Diámetro Estándar del Muñón Standard Shaft Diameter	Diámetro Total del Alojamiento Housing Bore	Ancho del Cojinete Width Bearing	Espesor Máximo de Pared Max Wall Thickness	Claro de Lubricación Oil Clearance	Torque Torque	Imagen del Cojinete / Arandela Image of the Bearing and Thrust Washer
mm Pulgadas	mm Pulgadas	mm Pulgadas	mm Pulgadas	mm Pulgadas	N.m Lbs.Ft	
52.941/52.954 2.084/2.085	55.999/56.020 2.205/2.206	22.00 0.866	1.509 0.0594	0.0355/0.0914 0.0014/0.0036	42 N.m 31 Lbs.Ft	 8 Piezas
62.939/62.954 2.478/2.479	67.000/67.020 2.638/2.639	18.39 0.724	2.009 0.0791	0.0254/0.0836 0.0010/0.0034	85 N.m 63 Lbs.Ft	   6 Piezas 2 Piezas 2 Piezas
62.939/62.954 2.478/2.479	67.000/67.020 2.638/2.639	24.10 0.949	2.009 0.0791	0.0254/0.0836 0.0010/0.0034	85 N.m 63 Lbs.Ft	 4 Piezas
71.501/71.750 2.815/2.825	86.401/86.650 3.402/3.411		2.050 0.0807			 8 Piezas
43.889/43.909 1.728/1.729	46.888/46.909 1.846/1.847	19.51 0.768	1.488 0.0586	0.0203/0.0635 0.0008/0.0025	35 a 41 N.m 26 a 30 Lbs.Ft	 8 Piezas
57.981/58.001 2.283/2.284	62.286/62.301 2.452/2.453	22.58 0.889	2.129 0.0838	0.0279/0.0889 0.0011/0.0035	91 a 109 N.m	    4 Piezas 4 Piezas 1 Pieza 1 Pieza
57.981/58.001 2.283/2.284	62.286/62.301 2.452/2.453	28.73 1.131	2.129 0.0838	0.0279/0.0889 0.0011/0.0035	67 a 80 Lbs.Ft	 8 Piezas
46.891/46.911 1.846/1.847	49.891/49.911 1.964/1.965	20.10 0.791	1.476 0.0581	0.0152/0.0685 0.0006/0.0027	23 a 26 N.m + 90° 17 a 19 Lbs.Ft + 90°	 4 Piezas
57.981/57.998 2.283/2.283	62.288/62.299 2.452/2.453	19.58 0.771	2.140 0.0840	0.0203/0.0431 0.0008/0.0017	18 a 22 N.m + 90°	   4 Piezas 5 Piezas 1 Pieza
57.981/57.998 2.283/2.283	62.288/62.299 2.452/2.453	24.71 0.973	2.140 0.0840	0.0203/0.0431 0.0008/0.0017	13 a 16 Lbs.Ft + 90°	 1 Pieza

FORD

MORESA

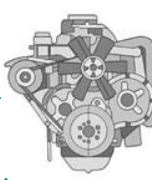
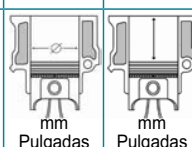
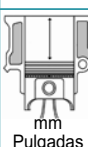











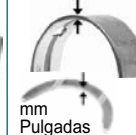
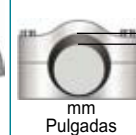



FORD LINCOLN MERCURY

CIL.	AÑO	MOTOR / APLICACIÓN		Diámetro del Cilindro Nominal Bore	Carrera Stroke	COJINETE, BUJE O ARANDELA	No. de Parte	Ubicación Location
CYL.	YEAR	ENGINE / APPLICATION		 mm Pulgadas	 mm Pulgadas	BEARING, BUSHING OR THURST WASHER	Part Number	
L4	1984-87	122 (2.0L) Mazda Diesel SOHC 8 valve (2000 cc) Escort, Lynx, Tempo, Topaz		86.00 3.386	86.00 3.386	COJINETE DE BIELA	4B1362 STD 010 020 030 040	TODOS
L4	1983-88	122 (2.0L) SOHC 8 valve (2000 cc) Ranger		89.41 3.520	79.38 3.125	COJINETE DE BIELA	4B984 STD 010 020 030	TODOS
	1974-97	140 (2.3L) SOHC 8 valve (2295 cc) Bobcat, Capri, Cougar, LTD, Marquis, Mustang, Ranger, T-Bird, Zephyr		96.02 3.781	79.50 3.125	COJINETE DE BANCADA	5C1117 STD 010 020 030	1-2-4-5 (A)
	1979-90	140 (2.3L) Turbo SOHC 8 valve (2295 cc) Capri, Cougar, LTD, Marquis, Mustang, Ranger, T-Bird, XR4Ti		96.02 3.781	79.50 3.125	Para 1974-90 solo motores con bujía sencilla.	5C1117 STD 010 020 030	3 (B, C)
	1998-01	153 (2.5L) SOHC 8 valve (2492 cc) Ranger		96.01 3.781	86.61 3.410	Para 1989-97 solo motores con doble bujía	5C1743 STD 010 020 030 040	1-2-4-5 (A, C)
						BUJE DE ARBOL 1983-88	MO1443M STD 010	1-2-3-4
						BUJE DE ARBOL 1983-88 Con ranura de lubricación en diámetro exterior	MO1842M STD	1-2-3-4
						BUJE DE FLECHA AUXILIAR 1983-88	MO1460M STD	1
								2

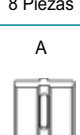
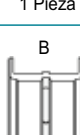
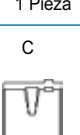
Línea Line

6



7

Diámetro Estándar del Muñón Standard Shaft Diameter	Diámetro Total del Alojamiento Housing Bore	Ancho del Cojinete Width Bearing	Espesor Máximo de Pared Max Wall Thickness	Claro de Lubricación Oil Clearance	Torque Torque	Imagen del Cojinete / Arandela Image of the Bearing and Thrust Washer
						
50.940/50.950 2.006/2.006	53.998/54.018 2.126/2.127	21.13 0.832	1.509 0.0594	0.0304/0.0660 0.0012/0.0026	65 a 69 N.m 48 a 51 Lbs.Ft	 8 Piezas
51.981/51.999 2.047/2.047	55.169/55.189 2.172/2.173	20.32 0.800	1.585 0.0624	0.0127/0.0762 0.0005/0.0030	41 a 49 N.m 30 a 36 Lbs.Ft	 8 Piezas
60.914/60.935 2.398/2.399	65.791/65.811 2.590/2.591	24.13 0.950	2.428 0.0956	0.0127/0.0787 0.0005/0.0031	109 a 122 N.m	A  B  C  8 Piezas 1 Pieza 1 Pieza
60.914/60.935 2.398/2.399	65.791/65.811 2.590/2.591	30.35 1.195	2.428 0.0956	0.0127/0.0787 0.0005/0.0031	80 a 90 Lbs.Ft	A  B  C  4 Piezas 1 Pieza 5 Piezas
56.010/56.030 2.205/2.206	60.886/60.907 2.397/2.398	24.13 0.950	2.428 0.0956	0.0203/0.0660 0.0008/0.0026	109 a 122 N.m	A  B  C  4 Piezas 1 Pieza 5 Piezas
56.010/56.030 2.205/2.206	60.886/60.907 2.397/2.398	30.35 1.195	2.428 0.0956	0.0203/0.0660 0.0008/0.0026	80 a 90 Lbs.Ft	A  B  C  4 Piezas 1 Pieza 5 Piezas
44.991/45.009 1.771/1.772	48.275/48.301 1.901/1.902	17.48 0.688	1.621 0.0638	0.0254/0.1219 0.0010/0.0048		4 Piezas
44.991/45.009 1.771/1.772	48.275/48.301 1.901/1.902	17.48 0.688	1.621 0.0638	0.0254/0.1219 0.0010/0.0048		4 Piezas
41.961/41.986 1.652/1.653	45.644/45.669 1.797/1.798	12.83 0.505	1.814 0.0714	0.0177/0.1193 0.0007/0.0047		1 Pieza
41.961/ 41.986 1.652/ 1.653	45.136/45.161 1.777/1.778	12.83 0.505	1.560 0.0614	0.0177/0.1193 0.0007/0.0047		1 Pieza

FORD



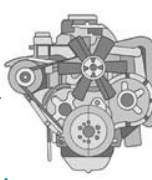

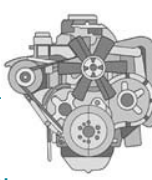
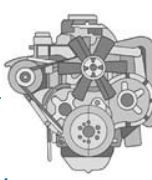







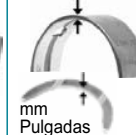
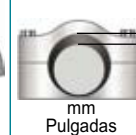



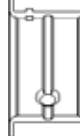

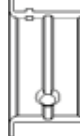

MORESA!

FORD LINCOLN MERCURY

CIL.	AÑO	MOTOR / APLICACIÓN		Diámetro del Cilindro Nominal Bore	Carrera Stroke	COJINETE, BUJE O ARANDELA	No. de Parte	Ubicación Location			
CYL.	YEAR	ENGINE / APPLICATION		mm Pulgadas	mm Pulgadas	BEARING, BUSHING OR THURST WASHER	Part Number				
L4	1989-92	133 (2.2L) Mazda SOHC 12 valve		86.00 3.386	94.00 3.700	COJINETE DE BIELA	4B1362 STD 010 020 030 040	TODOS			
	1989-92	133 (2.2L) Mazda Turbo SOHC 12 valve (2200 cc) Probe		86.00 3.386	94.00 3.700				COJINETE DE BANCADA	5C1803 STD 010 020 030	1-2-4-5 (A)
								3 (B, C)			
L4	1984-85	140 (2.3L) HSC OHV (2300 cc) Tempo, Topaz		93.45 3.679	84.00 3.307	COJINETE DE BIELA 1984-85	4B583 STD 010 020 030	TODOS			
	1984-94	140 (2.3L) HSC OHV (2300 cc) Tempo, Topaz		93.45 3.679	84.00 3.307				COJINETE DE BIELA 1986-94	4B1383 STD 010 020 030 040	TODOS
	1986-91	153 (2.5L) HSC OHV (2500 cc) Sable, Taurus		93.47 3.679	90.93 3.578	COJINETE DE BANCADA	5C1629 STD 010 020 030	1 (A, B)			
								BUJE DE ARBOL	MO1494M STD	1	
						2-3					
						4					

Línea Line
8



9







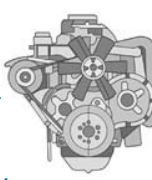
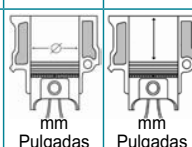
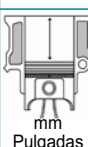





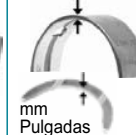
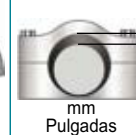









Diámetro Estándar del Muñón Standard Shaft Diameter	Diámetro Total del Alojamiento Housing Bore	Ancho del Cojinete Width Bearing	Espesor Máximo de Pared Max Wall Thickness	Claro de Lubricación Oil Clearance	Torque Torque	Imagen del Cojinete / Arandela Image of the Bearing and Thrust Washer
						
50.940/50.950 2.006/2.006	53.998/54.018 2.126/2.127	21.13 0.832	1.509 0.0594	0.0304/0.0660 0.0012/0.0026	65 a 69 N.m 48 a 51 Lbs.Ft	 8 Piezas
59.938/59.700 2.3598/2.3504	63.997/64.018 2.5196/2.5204	19.13 0.753	2.014 0.0793	0.0177/0.0762 0.0007/0.0030	83 a 88 N.m	A  B  C 
59.938/59.700 2.3598/2.3504	63.997/64.018 2.5196/2.5204	27.99 1.102	2.014 0.0793	0.0177/0.0762 0.0007/0.0030	61 a 65 Lbs.Ft	8 Piezas  1 Pieza  1 Piezas 
53.929/53.950 2.123/2.124	56.871/56.891 2.239/2.240	20.57 0.810	1.458 0.0574	0.0050/0.0711 0.0002/0.0028	28 a 35 N.m 21 a 26 Lbs.Ft	 8 Piezas
53.929/53.950 2.123/2.124	56.871/56.891 2.239/2.240	20.57 0.810	1.458 0.0574	0.0050/0.0711 0.0002/0.0028	28 a 35 N.m 21 a 26 Lbs.Ft	 8 Piezas
57.104/57.125 2.248/2.249	60.990/61.011 2.401/2.402	25.91 1.020	1.930 0.0760	0.0177/0.0838 0.0007/0.0033	81 a 100 N.m	A  B  C  D 
57.104/57.125 2.248/2.249	60.990/61.011 2.401/2.402	25.91 1.020	1.930 0.0760	0.0177/0.0838 0.0007/0.0033	60 a 74 Lbs.Ft	5 Piezas  1 Pieza  3 Piezas  1 Pieza 
50.988/51.013 2.007/2.008	55.987/56.012 2.204/2.205	18.54 0.730	2.471 0.0973	0.0304/0.1193 0.0012/0.0047		1 Pieza
50.988/51.013 2.007/2.008	55.588/55.613 2.189/2.190	18.54 0.730	2.471 0.0973	0.0381/0.1143 0.0015/0.0045		2 Piezas
50.988/51.013 2.007/2.008	55.987/56.012 2.204/2.205	12.95 0.510	2.471 0.0973	0.0304/0.1193 0.0012/0.0047		1 Pieza

FORD

MORESA!

FORD LINCOLN MERCURY



CIL.	AÑO	MOTOR / APLICACIÓN		Diámetro del Cilindro Nominal Bore	Carrera Stroke	COJINETE, BUJE O ARANDELA	No. de Parte	Ubicación Location
CYL.	YEAR	ENGINE / APPLICATION		 mm Pulgadas	 mm Pulgadas	BEARING, BUSHING OR THURST WASHER	Part Number	
10	L6	1960-64	144 (2.4L) OHV (2358 cc) E100, Falcon	88.90 3.500	63.50 2.500	COJINETE DE BIELA	6B583 STD 010 020 030 040	TODOS
		1961-72	170 (2.8L) OHV (2784 cc) Bronco, Calienta, Comet, Country Sedan, E100, E200, Fairlane, Falcon, Meteor, Mustang, P100	88.90 3.500	74.67 2.940	COJINETE DE BANCADA	4C518 STD 010 020	1-2-4 (A)
	1963-64	200 (3.3L) OHV (3276 cc) Bronco, Capri, Comet, Cougar, Fairlane, Fairmont, Falcon, Granada, LTD, Marquis, Maverick, Meteor, Monarch, Montego, Mustang, Ranchero, T-Bird, Torino, Villager, Voyager, Zephyr	88.90 3.500	74.67 2.940	COJINETE DE BANCADA	4C518 STD 010 020	3 (B)	
			93.47 3.680	79.50 3.130	BUJE DE ARBOL	MO1439M STD	1 2 3 4	
11	V6	1995-02	155 (2.5L) Duratec DOHC 24 valve(2500 cc) Contour, Cougar, Mystique	82.30 3.240	79.50 3.130	COJINETE DE BIELA	6B6155 STD 010 020 030	TODOS
		1996-06	181 (3.0L) Duratec DOHC 24 valve(2966 cc) Escape, LS, Mariner, Sable, Taurus	88.90 3.500	79.50 3.130	COJINETE DE BIELA	6B6155 STD 010 020 030	1-2-4 (A, B)
				88.90 3.500	79.50 3.130	COJINETE DE BANCADA	4C3000 STD 010 020 030	3 (A, C, D)
								3 (D)

Diámetro Estándar del Muñón Standard Shaft Diameter	Diámetro Total del Alojamiento Housing Bore	Ancho del Cojinete Width Bearing	Espesor Máximo de Pared Max Wall Thickness	Claro de Lubricación Oil Clearance	Torque Torque	Imagen del Cojinete / Arandela Image of the Bearing and Thrust Washer
						
53.929/53.950 2.123/2.124	56.871/56.891 2.239/2.240	20.57 0.810	1.458 0.0574	0.0050/0.0711 0.0002/0.0028	26 a 33 N.m 19 a 24 Lbs.Ft	 12 Piezas
57.104/57.125 2.248/2.249	60.990/61.011 2.401/2.402	25.91 1.020	1.928 0.0759	0.0177/0.0838 0.0007/0.0033	81 a 95 N.m	A  B 
57.104/57.125 2.248/2.249	60.990/61.011 2.401/2.402	32.28 1.271	1.925 0.0758	0.0177/0.0838 0.0007/0.0033	60 a 70 Lbs.Ft	6 Piezas  2 Piezas 
45.961/45.987 1.810/1.811	50.241/50.267 1.978/1.979	18.29 0.720	2.113 0.0832	0.0254/0.1270 0.0010/0.0050		1 Pieza 
45.961/45.987 1.810/1.811	49.860/49.886 1.963/1.964	18.29 0.720	1.923 0.0757	0.0254/0.1270 0.0010/0.0050		1 Pieza 
45.961/45.987 1.810/1.811	49.479/49.505 1.948/1.949	18.29 0.720	1.732 0.0682	0.0254/0.1270 0.0010/0.0050		1 Pieza 
45.961/45.987 1.810/1.811	49.098/49.124 1.933/1.934	18.29 0.720	1.542 0.0607	0.0254/0.1270 0.0010/0.0050		1 Pieza 
49.972/49.990 1.967/1.968	53.015/53.035 2.087/2.088	17.95 0.707	1.504 0.0592	0.0254/0.0635 0.0010/0.0025	35 a 45 N.m + 90 a 120° 26 a 33 Lbs.Ft + 90 a 120°	 12 Piezas
62.969/62.992 2.479/2.480	67.998/68.021 2.677/2.678	17.90 0.705	2.502 0.0985	0.0228/0.0482 0.0009/0.0019		A  B  C  D 
62.969/62.992 2.479/2.480	67.998/68.021 2.677/2.678	22.31 0.878	2.502 0.0985	0.0228/0.0482 0.0009/0.0019	39 N.m + 90° 29 Lbs.Ft + 90°	4 Piezas  3 Piezas  1 Pieza  1 Pieza 
			1.948 0.0767			

FORD

MORESA!

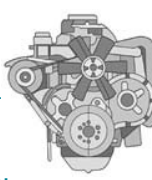
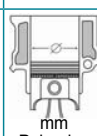
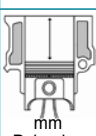
FORD LINCOLN MERCURY

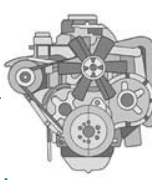
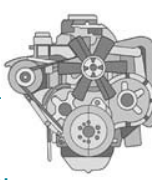

CIL.	AÑO	MOTOR / APLICACIÓN		Diámetro del Cilindro Nominal Bore	Carrera Stroke	COJINETE, BUJE O ARANDELA	No. de Parte	Ubicación Location
CYL.	YEAR	ENGINE / APPLICATION		 mm Pulgadas	 mm Pulgadas	BEARING, BUSHING OR THURST WASHER	Part Number	
12	V6	1972-73 159 (2.6L) OHV (2600 cc) Capri		89.91 3.540	66.80 2.630	COJINETE DE BIELA	6B723 STD 010 020 030 040	TODOS
						COJINETE DE BANCADA	4C1983 STD 010 020 030 040	1-2-4 (A) 3 (B)
13	V6	1974-79 1983-86 171 (2.8L) OHV (2800 cc) Bobcat, Capri, Mustang, Pinto, Aerostar, Bronco II, Ranger		92.96 3.660	68.58 2.700	COJINETE DE BIELA	6B723 STD 010 020 030 040	TODOS
						COJINETE DE BANCADA	4C1983 STD 010 020 030 040	1-2-4 (A) 3 (B)
		1983-86 171 (2.8L) OHV (2800 cc) Aerostar, Bronco II, Ranger		BUJE DE ARBOL 1983-86	MO1495M STD	1 2 3 4		
				BUJE DE ARBOL 1983-86 Con ranura de lubricación	MO1793M STD	1 2 3 4		

Diámetro Estándar del Muñón Standard Shaft Diameter	Diámetro Total del Alojamiento Housing Bore	Ancho del Cojinete Width Bearing	Espesor Máximo de Pared Max Wall Thickness	Claro de Lubricación Oil Clearance	Torque Torque	Imagen del Cojinete / Arandela Image of the Bearing and Thrust Washer
mm Pulgadas	mm Pulgadas	mm Pulgadas	mm Pulgadas	mm Pulgadas	N.m Lbs.Ft	
53.980/54.000 2.125/2.126	56.820/56.840 2.237/2.238	16.48 0.649	1.402 0.0552	0.0101/0.0732 0.0004/0.0030	28 a 34 N.m 21 a 25 Lbs.Ft	 16 Piezas
56.980/57.000 2.243/2.244	60.620/60.640 2.387/2.387	21.59 0.850	1.803 0.0710	0.0152/0.0812 0.0006/0.0032	88 a 102 N.m	 6 Piezas
56.980/57.000 2.243/2.244	60.620/60.640 2.387/2.387	26.29 1.035	1.803 0.0710	0.0152/0.0812 0.0006/0.0032	65 a 75 Lbs.Ft	 2 Piezas
53.980/54.000 2.125/2.126	56.820/56.840 2.237/2.238	16.48 0.649	1.402 0.0552	0.0101/0.0762 0.0004/0.0030	28 a 34 N.m 21 a 25 Lbs.Ft	 16 Piezas
56.980/57.000 2.243/2.244	60.620/60.640 2.387/2.387	21.59 0.850	1.803 0.0710	0.0152/0.0812 0.0006/0.0032	88 a 102 N.m	 6 Piezas
56.980/57.000 2.243/2.244	60.620/60.640 2.387/2.387	26.29 1.035	1.803 0.0710	0.0152/0.0812 0.0006/0.0032	65 a 75 Lbs.Ft	 2 Piezas
43.904/43.922 1.728/1.729	47.015/47.041 1.851/1.852	19.94 0.785	1.532 0.0603	0.0304/0.1041 0.0012/0.0041		1 Pieza
43.523/43.541 1.713/1.714	46.634/46.660 1.836/1.837	17.91 0.705	1.516 0.0597	0.0304/0.1041 0.0012/0.0041		1 Pieza
43.142/43.160 1.698/1.699	46.253/46.279 1.821/1.822	17.91 0.705	1.532 0.0603	0.0304/0.1041 0.0012/0.0041		1 Pieza
42.761/42.779 1.683/1.684	45.872/45.898 1.806/1.807	15.24 0.600	1.532 0.0603	0.0304/0.1041 0.0012/0.0041		1 Pieza
43.904/43.922 1.728/1.729	47.015/47.041 1.851/1.852	19.94 0.785	1.532 0.0603	0.0304/0.1041 0.0012/0.0041		1 Pieza
43.523/43.541 1.713/1.714	46.634/46.660 1.836/1.837	17.91 0.705	1.516 0.0597	0.0304/0.1041 0.0012/0.0041		1 Pieza
43.142/43.160 1.698/1.699	46.253/46.279 1.821/1.82	17.91 0.705	1.532 0.0603	0.0304/0.1041 0.0012/0.0041		1 Pieza
42.761/42.779 1.683/1.684	45.872/45.898 1.806/1.807	15.24 0.600	1.532 0.0603	0.0304/0.1041 0.0012/0.0041		1 Pieza

FORD

MORESA

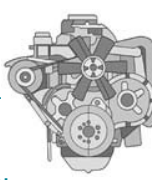
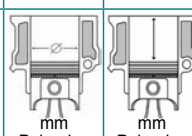
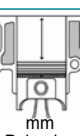
FORD LINCOLN MERCURY



CIL.	AÑO	MOTOR / APLICACIÓN		Diámetro del Cilindro Nominal Bore	Carrera Stroke	COJINETE, BUJE O ARANDELA	No. de Parte	Ubicación Location
CYL.	YEAR	ENGINE / APPLICATION		 mm Pulgadas	 mm Pulgadas	BEARING, BUSHING OR THURST WASHER	Part Number	
14	V6							
	1993-98	181 (3.0L) Nissan SOHC 12 valve (2960 cc) Villager	87.00 3.420	83.00 3.270	COJINETE DE BIELA	6B1591 STD 010 020 030 040	TODOS	
	1999-02	199.8 (3.3L) Nissan SOHC 12 valve (3275 cc) Villager	91.50 3.600	83.00 3.270	COJINETE DE BANCADA	4C1951 STD 010 020 030	1 (A, B)	
							2-3 (C, D)	
				4 (E, F)				
15	V6							
	1986-06	183 (3.0L) OHV exc. SHO eng. (3000 cc) Aerostar, Probe, Ranger, Sable, Taurus, Tempo, Topaz, Windstar	89.00 3.500	80.00 3.150	COJINETE DE BIELA	6B1385 STD 010 020 030	TODOS	
					COJINETE DE BANCADA	4C1702 STD 010 020 030	1-2 (A,B)	
							4 (C, D)	
							3 (E, F)	
					BUJE DE ARBOL	MO1843M STD	1	
				2-3				
				4				

Diámetro Estándar del Muñón Standard Shaft Diameter	Diámetro Total del Alojamiento Housing Bore	Ancho del Cojinete Width Bearing	Espesor Máximo de Pared Max Wall Thickness	Claro de Lubricación Oil Clearance	Torque Torque	Imagen del Cojinete / Arandela Image of the Bearing and Thrust Washer
49.961/49.987 1.967/1.968	52.984/53.011 2.086/2.087	16.99 0.669	1.509 0.0594	0.0152/0.0609 0.0006/0.0024	45 a 54 N.m 33 a 40 Lbs.Ft	 16 Piezas
62.951/62.974 2.478/2.479	66.644/66.672 2.623/2.624	22.5 0.886	1.829 0.0720	0.0101/0.0863 0.0004/0.0034	91 a 100 N.m 67 a 74 Lbs.Ft	 1 Pza. 1 Pza. 2 Pzas. 2 Pzas. 1 Pza. 1 Pza.
62.951/62.974 2.478/2.479	66.644/66.672 2.623/2.624	19.00 0.748	1.829 0.0720	0.0101/0.0863 0.0004/0.0034		
62.951/62.974 2.478/2.479	66.644/66.672 2.623/2.624	28.8 1.134	1.829 0.0720	0.0101/0.0863 0.0004/0.0034		
53.983/54.003 2.125/2.126	57.150/57.170 2.250/2.251	19.25 0.758	1.570 0.0618	0.0254/0.0685 0.0010/0.0027	31 a 39 N.m 23 a 29 Lbs.Ft	 12 Piezas
63.983/64.003 2.519/2.520	68.885/68.903 2.712/2.713	18.69 0.736	2.443 0.0962	0.0254/0.0584 0.0010/0.0023	85 a 94 N.m 63 a 69 Lbs.Ft	 2 Pzas. 2 Pzas. 1 Pza. 1 Pza. 1 Pza. 1 Pza.
63.983/64.003 2.519/2.520	68.885/68.903 2.712/2.713	27.00 1.063	2.441 0.0961	0.0254/0.0584 0.0010/0.0023		
63.983/64.003 2.519/2.520	68.885/68.903 2.712/2.713	25.65 1.010	2.441 0.0961	0.0254/0.0584 0.0010/0.0023		
50.988/51.013 2.007/2.008	54.689/54.714 2.1531/2.1541	24.51 0.965	1.811 0.0713	0.0254/0.0762 0.0010/0.0030		1 Pieza
50.988/51.013 2.007/2.008	54.188/52.214 2.1334/2.1344	13.76 0.542	1.559 0.0614	0.0254/0.0762 0.0010/0.0030		1 Pieza
50.988/51.013 2.007/2.008	54.689/54.714 2.1531/2.1541	24.51 0.965	1.811 0.0713	0.0254/0.0762 0.0010/0.0030		1 Pieza

FORD













MORESA

FORD LINCOLN MERCURY

CIL.	AÑO	MOTOR / APLICACIÓN		Diámetro del Cilindro Nominal Bore	Carrera Stroke	COJINETE, BUJE O ARANDELA	No. de Parte	Ubicación
				mm Pulgadas	mm Pulgadas	BEARING, BUSHING OR THURST WASHER		Location
CYL.	YEAR	ENGINE / APPLICATION						
16	L6	1965-83 200 (3.3L) OHV (3300 cc) Bronco, Caliente, Capri, Comet, Cougar, Fairlane, Fairmont, Falcon, Granada, LTD, Marquis, Maverick, Meteor, Monarch, Montego, Mustang, Ranchero, T-Bird, Torino, Villager, Voyager, Zephyr		93.47 3.680	79.50 3.130	COJINETE DE BIELA	6B583 STD 010 020 030 040	TODOS
						COJINETE DE BANCADA 1965-75	7C771 STD 010 020	1-2-3-4-6-7 (A)
						COJINETE DE BANCADA 1976-83	7C1389 STD 010 020 030	5 (B)
						COJINETE DE BANCADA 1976-83	7C1389 STD 010 020 030	1-2-3-4-6-7 (A, B)
						BUJE DE ARBOL	MO1439M STD	1
								2
								3
								4

Línea
Line





16

Diámetro Estándar del Muñón Standard Shaft Diameter	Diámetro Total del Alojamiento Housing Bore	Ancho del Cojinete Width Bearing	Espesor Máximo de Pared Max Wall Thickness	Claro de Lubricación Oil Clearance	Torque Torque	Imagen del Cojinete / Arandela Image of the Bearing and Thrust Washer
mm Pulgadas	mm Pulgadas	mm Pulgadas	mm Pulgadas	mm Pulgadas	N.m Lbs.Ft	
53.929/53.950 2.123/2.124	56.871/56.891 2.239/2.240	20.57 0.810	1.458 0.0574	0.0050/0.0711 0.0002/0.0028	26 a 33 N.m 19 a 24 Lbs.Ft	 12 Piezas
57.104/57.125 2.248/2.249	60.990/61.011 2.401/2.402	25.91 1.020	1.928 0.0759	0.0177/0.0838 0.0007/0.0033	81 a 95 N.m	A  B 
57.104/57.125 2.248/2.249	60.990/61.011 2.401/2.402	32.28 1.271	1.925 0.0758	0.0177/0.0838 0.0007/0.0033	60 a 70 Lbs.Ft	6 Piezas  2 Piezas. 
57.104/57.125 2.248/2.249	60.990/61.011 2.401/2.402	25.91 1.020	1.928 0.0759	0.0177/0.0838 0.0007/0.0033	81 a 95 N.m	A  B  C  D 
57.104/57.125 2.248/2.249	60.990/61.011 2.401/2.402	32.28 1.271	1.925 0.0758	0.0177/0.0838 0.0007/0.0033	60 a 70 Lbs.Ft	6 Pzas.  6 Pzas.  1 Pza.  1 Pza. 
45.961/45.987 1.810/1.811	50.241/50.267 1.978/1.979	18.29 0.720	2.113 0.0832	0.0254/0.1270 0.0010/0.0050		1 Pieza
45.961/45.987 1.810/1.811	49.860/49.886 1.963/1.964	18.29 0.720	1.923 0.0757	0.0254/0.1270 0.0010/0.0050		1 Pieza
45.961/45.987 1.810/1.811	49.479/49.505 1.948/1.949	18.29 0.720	1.732 0.0682	0.0254/0.1270 0.0010/0.0050		1 Pieza
45.961/45.987 1.810/1.811	49.098/49.124 1.933/1.934	18.29 0.720	1.542 0.0607	0.0254/0.1270 0.0010/0.0050		1 Pieza

FORD

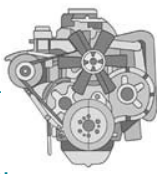

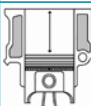
MORESA!

FORD LINCOLN MERCURY

CIL.	AÑO	MOTOR / APLICACIÓN		Diámetro del Cilindro Nominal Bore	Carrera Stroke	COJINETE, BUJE O ARANDELA	No. de Parte	Ubicación Location
CYL.	YEAR	ENGINE / APPLICATION		 mm Pulgadas	 mm Pulgadas	BEARING, BUSHING OR THURST WASHER	Part Number	
V6	1982-04	232 (3.8L) OHV (3800 cc) Capri, Continental, Cougar, F100, Granada, LTD, Marquis, Mustang, Sable, Thunderbird, Taurus, Windstar	96.80 3.811	86.00 3.386	COJINETE DE BIELA 1982-95 232 OHV 1989-95 232 Supercharged OHV	6B1283 STD 010 020 030 040	TODOS	
	1989-95	232 (3.8L) Supercharged OHV (3800 cc) Cougar, Thunderbird	96.80 3.811	86.00 3.386	COJINETE DE BIELA 1996-04 232 OHV 2004 238 OHV	6B1667 STD 010 020 030 040	TODOS	
	2004	238 (3.9L) OHV (3900 cc) Freestar, Mustang	96.80 3.811	88.00 3.464				
					COJINETE DE BANCADA	4C1561 STD 010 020 030 040	1-2-4 (A, B) 3 (C, D)	
					COJINETE DE BANCADA 1982-04 232 OHV 2004 238 OHV	4C1812 STD 010 020 030	1-2-4 (A, B) 3 (C, D)	
					BUJE DE ARBOL 1982-87	MO1493M STD	1-4 2-3	
					BUJE DE ARBOL 1988-04	MO1824M STD	1-4 2-3	
					BUJE DE FLECHA BALANCEADORA 1988-94	MO1807M STD	1-2	

Línea Line

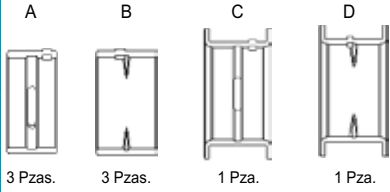
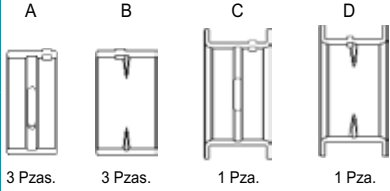

17







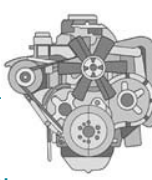
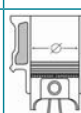
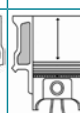

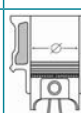
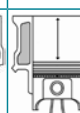
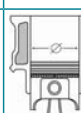
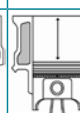

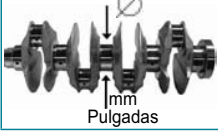

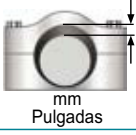

Diámetro Estándar del Muñón Standard Shaft Diameter	Diámetro Total del Alojamiento Housing Bore	Ancho del Cojinete Width Bearing	Espesor Máximo de Pared Max Wall Thickness	Claro de Lubricación Oil Clearance	Torque Torque	Imagen del Cojinete / Arandela Image of the Bearing and Thrust Washer
mm Pulgadas	mm Pulgadas	mm Pulgadas	mm Pulgadas	mm Pulgadas	N.m Lbs.Ft	
58.671/58.699 2.310/2.311	61.636/61.656 2.426/2.427	17.02 0.670	1.466 0.0577	0.0050/0.0687 0.0002/0.0031	42 a 49 N.m 31 a 36 Lbs.Ft	 12 Piezas
58.671/58.699 2.310/2.311	61.636/61.656 2.426/2.427	17.02 0.670	1.466 0.0577	0.0050/0.0687 0.0002/0.0031	42 a 49 N.m 31 a 36 Lbs.Ft	 12 Piezas
63.983/64.003 2.519/2.520	68.890/68.910 2.712/2.713	21.79 0.858	2.451 0.0965	0.0127/0.0584 0.0005/0.0023	88 a 110 N.m	 3 Pzas. 3 Pzas. 1 Pza. 1 Pza.
63.983/64.003 2.519/2.520	68.890/68.910 2.712/2.713	29.62 1.166	2.438 0.0960	0.0127/0.0584 0.0005/0.0023	65 a 81 Lbs.Ft	 3 Pzas. 3 Pzas. 1 Pza. 1 Pza.
52.083/52.108 2.051/2.052	55.664/55.690 2.192/2.193	16.13 0.635	1.763 0.0694	0.0203/0.1016 0.0008/0.0040		2 Piezas
520.83/52.108 2.051/2.052	55.283/55.309 2.177/2.178	14.10 0.555	1.572 0.0619	0.0203/0.1016 0.0008/0.0040		2 Piezas
52.083/52.108 2.051/2.052	55.664/55.690 2.192/2.193	16.13 0.635	1.763 0.0694	0.0228/0.0990 0.0009/0.0039		2 Piezas
520.827/52.108 2.051/2.052	55.283/55.309 2.177/2.178	13.97 0.550	1.572 0.0619	0.0228/0.0990 0.0009/0.0039		2 Piezas
52.083/52.108 2.051/2.052	55.664/55.690 2.192/2.193	16.74 0.659	1.773 0.0698	0.0228/0.0990 0.0009/0.0039		2 Piezas

FORD

MORESA!

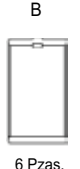
FORD LINCOLN MERCURY

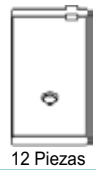
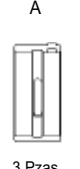
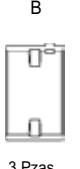

CIL.	AÑO	MOTOR / APLICACIÓN		Diámetro del Cilindro Nominal Bore	Carrera Stroke	COJINETE, BUJE O ARANDELA	No. de Parte	Ubicación Location
CYL.	YEAR	ENGINE / APPLICATION		 mm Pulgadas	 mm Pulgadas	BEARING, BUSHING OR THURST WASHER	Part Number	
18	L6	1965-74 240 (3.9L) OHV (3900 cc) B500, Country Squire, Custom, E100, E200, F100, F250, F350, F500, Galaxie, N500, N600, P100, P350, P400, P500	 mm Pulgadas	 mm Pulgadas	101.60 4.000 80.77 3.180	COJINETE DE BIELA	6B699 STD 010 020 030 040	TODOS (A, B)
						COJINETE DE BANCADA	7C979 STD 010 020 030 040	1-2-3-4-6-7 (A, B)
								5 (C, D)
BUJE DE ARBOL	MO1450M STD 010	1-2-3-4						
19	V6	1990-00 244 (4.0L) OHV (4000 cc) Aerostar, Ranger	 mm Pulgadas	 mm Pulgadas	100.00 3.940 84.00 3.310 100.40 3.953 84.40 3.323 100.40 3.953 84.40 3.323	COJINETE DE BIELA	6B723 STD 010 020 030 040	TODOS
						COJINETE DE BANCADA	4C2006 STD 010 020 030 040	1-2-4 (A, B)
		BUJE DE ARBOL						MO1844M STD
						1		
						2		
						3		
BUJE DE FLECHA AUXILIAR	MOFG-53 STD	1						
		2						
1997-01 244 (4.0L) SOHC 12 valve (4016 cc) Explorer, Mountaineer, Ranger	2002-03 244 (4.0L) Flex Fuel SOHC 12 valve (4016 cc) Explorer	1997-01 244 SOHC 12 valve 2002-03 244 Flex Fuel SOHC 12 valve	100.40 3.953 84.40 3.323	84.40 3.323	100.40 3.953 84.40 3.323	BUJE DE BIELA COJINETE DE BANCADA BUJE DE ARBOL BUJE DE FLECHA AUXILIAR	6B723 STD 010 020 030 040 4C2006 STD 010 020 030 040 MO1844M STD MOFG-53 STD	TODOS 1-2-4 (A, B) 3 (C, D) 1 2 3 4 1 2







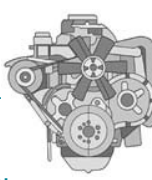
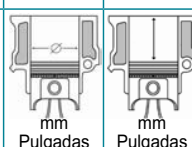
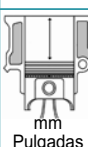

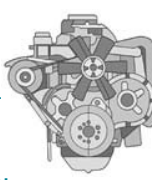
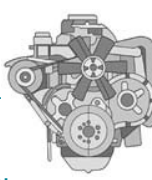
Diámetro Estándar del Muñón Standard Shaft Diameter	Diámetro Total del Alojamiento Housing Bore	Ancho del Cojinete Width Bearing	Espesor Máximo de Pared Max Wall Thickness	Claro de Lubricación Oil Clearance	Torque Torque	Imagen del Cojinete / Arandela Image of the Bearing and Thrust Washer
						
53.919/53.939 2.123/2.124	57.785/57.805 2.275/2.276	20.32 0.800	1.920 0.0756	0.0050/0.0711 0.0002/0.0028	54 a 61 N.m 40 a 45 Lbs.Ft	  6 Piezas 6 Piezas
60.914/60.935 2.398/2.399	65.791/65.811 2.590/2.591	24.13 0.950	2.426 0.0955	0.0127/0.0787 0.0005/0.0031	81 a 95 N.m	    6 Pzas. 6 Pzas. 1 Pza. 1 Pza.
60.914/60.935 2.398/2.399	65.791/65.811 2.590/2.591	30.35 1.195	2,426 0,0955	0.0127/0.0787 0.0005/0.0031	60 a 70 Lbs.Ft	
51.232/ 51.257 2.017/ 2.018	54.458/ 54.483 2.144/ 2.145	21.97 0.865	1.585 0.0624	0.0254/0.1270 0.0010/0.0050		4 Piezas
53.980/54.000 2.125/2.126	56.820/56.840 2.237/2.238	16.48 0.649	1.402 0.0552	0.0101/0.0762 0.0004/0.0030	28 a 34 N.m 21 a 25 Lbs.Ft	 12 Piezas
56.980/57.000 2.243/2.244	60.620/60.640 2.386/2.387	21.59 0.850	1.803 0.0710	0.0152/0.0812 0.0006/0.0032	89 a 99 N.m	    3 Pzas. 3 Pzas. 1 Pza. 1 Pza.
56.980/57.000 2.243/2.244	60.620/60.640 2.386/2.387	26.29 1.035	1.803 0.0710	0.0152/0.0812 0.0006/0.0032	66 a 67 Lbs.Ft	
49.571/49.391 1.951/1.952	52.751/52.791 2.077/2.078	19.81 0.780	1.567 0.0617	0.0254/0.1168 0.0010/0.0046		1Pieza
49.10/49.30 1.937/1.938	52.370/52.410 2.062/2.063	17.91 0.705	1.559 0.0614	0.0203/0.1117 0.0008/0.0044		1Pieza
48.829/48.848 1.922/1.923	51.989/52.029 2.047/2.048	17.91 0.705	1.559 0.0614	0.0203/0.1117 0.0008/0.0044		1Pieza
48.440/48.461 1.907/1.908	51.610/51.651 2.032/2.033	14.98 0.590	1.562 0.0615	0.0254/0.1168 0.0010/0.0046		1Pieza
	47.046 1.852	29.01 1.142	1.549 0.0610			1Pieza
	45.903 1.807	22.99 0.905	1.549 0.0610			1Pieza

FORD

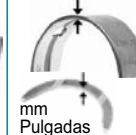
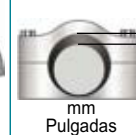
MORESA!

FORD LINCOLN MERCURY

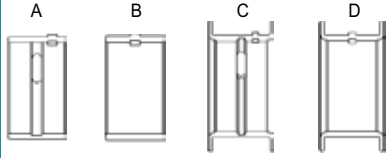
CIL.	AÑO	MOTOR / APLICACIÓN		Diámetro del Cilindro Nominal Bore	Carrera Stroke	COJINETE, BUJE O ARANDELA	No. de Parte	Ubicación Location
CYL.	YEAR	ENGINE / APPLICATION		 mm Pulgadas	 mm Pulgadas	BEARING, BUSHING OR THURST WASHER	Part Number	
20	L6	1969-80 250 (4.1L) OHV (4100 cc) Comet, Fairlane, Falcon, Gran Torino, Granada, Maverick, Monarch, Montego, Mustang, Ranchero, Torino		93.47 3.680	99.31 3.910	COJINETE DE BIELA	6B583 STD 010 020 030 040	TODOS
						COJINETE DE BANCADA	7C979 STD 010 020 030 040	1-2-3-4-6-7 (A, B)
								5 (C, D)
						BUJE DE ARBOL	MO1439M STD	1 2 3 4
21	V6	1997-06 256 (4.2L) OHV (4190 cc) E150, E250, F150, F250, Freestar		96.80 3.811	95.00 3.740	COJINETE DE BIELA 1996-04	6B1667 STD 010 020 030 040	TODOS
						COJINETE DE BANCADA	4C1812 STD 010 020 030	1-2-4 (A, B)
								3 (C, D)
						BUJE DE ARBOL	MO1824M STD	1-4 2-3
BUJE DE FLECHA BALANCEADORA	MO1807M STD	1-2						

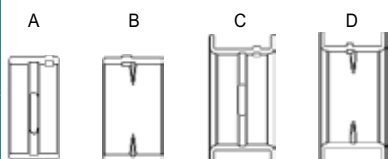
Diámetro Estándar del Muñón Standard Shaft Diameter	Diámetro Total del Alojamiento Housing Bore	Ancho del Cojinete Width Bearing	Espesor Máximo de Pared Max Wall Thickness	Claro de Lubricación Oil Clearance	Torque Torque	Imagen del Cojinete / Arandela Image of the Bearing and Thrust Washer
						
53.929/53.950 2.123/2.124	56.871/56.891 2.239/2.240	20.57 0.810	1.458 0.0574	0.0050/0.0711 0.0002/0.0028	26 a 33 N.m 19 a 24 Lbs.Ft	 12 Piezas
60.914/60.935 2.398/2.399	65.791/65.811 2.590/2.591	24.13 0.950	2.426 0.0955	0.0127/0.0787 0.0005/0.0031	81 a 95 N.m	 6 Pzas. 6 Pzas. 1 Pza. 1 Pza.
60.914/60.935 2.398/2.399	65.791/65.811 2.590/2.591	30.35 1.195	2.426 0.0955	0.0127/0.0787 0.0005/0.0031	60 a 70 Lbs.Ft	
45.961/45.987 1.810/1.811	50.241/50.267 1.978/1.979	18.29 0.720	2.113 0.0832	0.0254/0.1270 0.0010/0.0050		1 Pieza
45.961/45.987 1.810/1.811	49.860/49.886 1.963/1.964	18.29 0.720	1.923 0.0757	0.0254/0.1270 0.0010/0.0050		1 Pieza
45.961/45.987 1.810/1.811	49.479/49.505 1.948/1.949	18.29 0.720	1.732 0.0682	0.0254/0.1270 0.0010/0.0050		1 Pieza
45.961/45.987 1.810/1.811	49.098/49.124 1.933/1.934	18.29 0.720	1.542 0.0607	0.0254/0.1270 0.0010/0.0050		1 Pieza
58.671/58.699 2.310/2.311	61.636/61.656 2.426/2.427	17.02 0.670	1.466 0.0577	0.0050/0.0787 0.0002/0.0031	42 a 49 N.m 31 a 36 Lbs.Ft	 12 Piezas
63.983/64.003 2.519/2.520	68.890/68.910 2.712/2.713	21.79 0.858	2.451 0.0965	0.0127/0.0584 0.0005/0.0023	88 a 110 N.m	 3 Pzas. 3 Pzas. 1 Pza. 1 Pza.
63.983/64.003 2.519/2.520	68.890/68.910 2.712/2.713	29.62 1.166	2.438 0.0960	0.0127/0.0584 0.0005/0.0023	65 a 81 Lbs.Ft	
52.083/52.108 2.051/2.052	55.664/55.690 2.192/2.193	16.13 0.635	1.763 0.0694	0.0228/0.0990 0.0009/0.0039		2 Piezas
52.083/52.108 2.051/2.052	55.283/55.309 2.177/2.178	13.97 0.550	1.572 0.0619	0.0228/0.0990 0.0009/0.0039		2 Piezas
52.083/52.108 2.051/2.052	55.664/55.690 2.192/2.193	16.74 0.659	1.773 0.0698	0.0228/0.0990 0.0009/0.0039		2 Piezas

FORD

MORESA!

FORD LINCOLN MERCURY

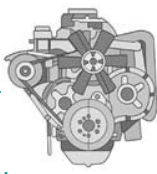
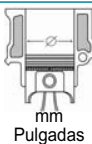
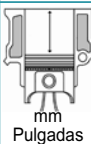
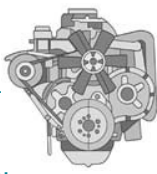
CIL.	AÑO	MOTOR / APLICACIÓN		Diámetro del Cilindro Nominal Bore	Carrera Stroke	COJINETE, BUJE O ARANDELA	No. de Parte	Ubicación
				 mm Pulgadas	 mm Pulgadas	BEARING, BUSHING OR THURST WASHER		Part Number
L6	1965-96	300 (4.9L) OHV (4900 cc) B500, B600, Bronco, C500, C600, E100, E150, E250, E350, F100, F150, F250, F350, F500, F600, LN500, LN600, N500, N600, P100, P350, P400, P500, P600		101.60 4.000	101.09 3.980	COJINETE DE BIELA	6B699 STD 010 020 030 040	TODOS (A, B)
						COJINETE DE BANCADA	7C979 STD 010 020 030 040	1-2-3-4-6-7 (A, B)
						BUJE DE ARBOL 1965 - 85	MO1450M STD 010	5 (C, D)
						BUJE DE ARBOL 1985 - 96	MO1781M STD	1-2-3-4
								1-4
		2-3						

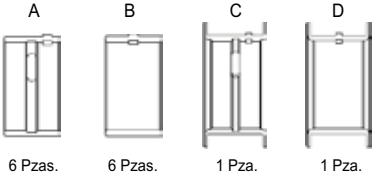

Línea
Line

22

Diámetro Estándar del Muñón Standard Shaft Diameter	Diámetro Total del Alojamiento Housing Bore	Ancho del Cojinete Width Bearing	Espesor Máximo de Pared Max Wall Thickness	Claro de Lubricación Oil Clearance	Torque Torque	Imagen del Cojinete / Arandela Image of the Bearing and Thrust Washer
mm Pulgadas	mm Pulgadas	mm Pulgadas	mm Pulgadas	mm Pulgadas	N.m Lbs.Ft	
53.919/53.939 2.123/2.124	57.785/57.805 2.275/2.276	20.32 0.800	1.920 0.0756	0.0050/0.0711 0.0002/0.0028	54 a 61 N.m 40 a 45 Lbs.Ft	 6 Piezas 6 Piezas
60.914/60.935 2.398/2.399	65.791/65.811 2.590/2.591	24.13 0.950	2.426 0.0955	0.0127/0.0787 0.0005/0.0031	81 a 95 N.m	 6 Pzas. 6 Pzas. 1 Pza. 1 Pza.
60.914/60.935 2.398/2.399	65.791/65.811 2.590/2.591	30.35 1.195	2.426 0.0955	0.0127/0.0787 0.0005/0.0031	60 a 70 Lbs.Ft	
51.232/51.257 2.017/2.018	54.458/54.483 2.144/2.145	21.97 0.865	1.585 0.0624	0.0254/0.1270 0.0010/0.0050		4 Piezas
51.232/51.257 2.017/2.018	54.813/54.864 2.158/2.160	21.97 0.865	1.765 0.0695	0.0254/0.1270 0.0010/0.0050		2 Piezas
51.232/51.257 2.017/2.018	54.458/54.483 2.144/2.145	21.97 0.865	1.585 0.0624	0.0254/0.1270 0.0010/0.0050		2 Piezas

FORD

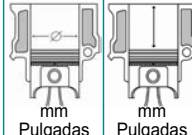
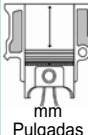
MORESA

CIL.	AÑO	MOTOR / APLICACIÓN		Diámetro del Cilindro Nominal Bore	Carrera Stroke	COJINETE, BUJE O ARANDELA	No. de Parte	Ubicación Location
CYL.	YEAR	ENGINE / APPLICATION		 mm Pulgadas	 mm Pulgadas	BEARING, BUSHING OR THURST WASHER	Part Number	
V8	1962-63	221 (3.7L) OHV (3619 cc) Fairlane, Meteor	88.90 3.500	73.15 2.880	COJINETE DE BIELA	8B634 STD 010 020 030 040	TODOS	
	1980-82	255 (4.2L) OHV (4200 cc) Capri, Cougar, F100, Fairmont, Granada, LTD, Marquis, Monarch, Mustang, T-Brid, Zephyr	93.47 3.680	76.20 3.000				
	1962-65	260 (4.3L) OHV (4258 cc) Calienta, Comet, Fairlane, Falcon, Meteor, Mustang	96.52 3.800	72.89 2.870	COJINETE DE BANCADA	5C590 STD 010 020 030 040	1-2-4-5 (A, B)	
	1965-68	289 (4.7L) OHV exc. Vin "K" and w/ A4 trans.	101.60 4.000	72.90 2.870				
	1963-64 1963-68	289 (4.7L) OHV w/ A4 trans 289 (4.7L) OHV w/ Vin "K" (4733 cc) Bronco, Calienta, Capri, Comet, Cougar, Country Sedan, Country Squire, Custom, Cyclone, Fairlane, Falcon, Galaxie, LTD, Mustang, Ranchero, Torino, Villager, Voyager					3 (C, D)	
	1969-71	302 (4.9L) OHV w/ Boss and Eliminator engs. (4946 cc) Cougar, Mustang	101.60 4.000	76.20 3.000	BUJE DE ARBOL	MO1204M STD 010 020 030	1	
	1968-01	302 (5.0L) OHV exc. Boss and Eliminator engs.	101.60 4.000	76.20 3.000			2	
	1982-95	302 (5.0L) High Output OHV exc. Boss and Eliminator engs. (5000 cc) Bronco, Capri, Comet, Continental, Cougar, Crown Victoria, Custom, Cyclone, E100, E150, E200, E250, E300, Explorer, F100, F150, F250, Fairlane, Falcon, Galaxie, Gran Torino, Granada, Grand Marquis, LTD, Mark VII, Mark VI, Marquis, Maverick, Monarch, Montego, Mountaineer, Mustang, Ranchero, T-Bird, Torino, Towncar, Versailles, Zephyr					3	
							4	
							5	

Línea Line



23

Diámetro Estándar del Muñón Standard Shaft Diameter	Diámetro Total del Alojamiento Housing Bore	Ancho del Cojinete Width Bearing	Espesor Máximo de Pared Max Wall Thickness	Claro de Lubricación Oil Clearance	Torque Torque	Imagen del Cojinete / Arandela Image of the Bearing and Thrust Washer
53.919/53.939 2.123/2.124	56.871/56.891 2.239/2.240	18.44 0.726	1.463 0.0576	0.0152/0.0711 0.0006/0.0028	26 a 33 N.m 19 a 24 Lbs.Ft	 12 Piezas
57.104/57.125 2.248/2.249	62.006/62.027 2.441/2.442	22.61 0.890	2.443 0.0962	0.0152/0.0711 0.0006/0.0028	81 a 95 N.m 60 a 70 Lbs.Ft	 A: 4 Pzas. B: 4 Pzas. C: 1 Pza. D: 1 Pza.
57.104/57.125 2.248/2.249	62.006/62.027 2.441/2.442	28.78 1.133	2.443 0.0962	0.0152/0.0711 0.0006/0.0028		
52.845/52.870 2.081/2.082	55.956/56.007 2.203/2.205	16.76 0.660	1.529 0.0602	0.0254/0.1270 0.0010/0.0050		1 Pieza
52.464/52.489 2.066/2.067	55.575/55.626 2.188/2.190	16.76 0.660	1.529 0.0602	0.0254/0.1270 0.0010/0.0050		1 Pieza
52.083/52.108 2.051/2.052	55.194/55.245 2.173/2.175	16.76 0.660	1.529 0.0602	0.0254/0.1270 0.0010/0.0050		1 Pieza
51.702/51.727 2.036/2.037	54.813/54.864 2.158/2.160	16.76 0.660	1.529 0.0602	0.0254/0.1270 0.0010/0.0050		1 Pieza
51.321/51.346 2.021/2.022	54.432/54.483 2.143/2.145	16.76 0.660	1.529 0.0602	0.0254/0.1270 0.0010/0.0050		1 Pieza

FORD

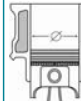
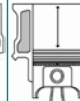

MORESA!

FORD LINCOLN MERCURY

CIL.	AÑO	MOTOR / APLICACIÓN		Diámetro del Cilindro		Carrera	COJINETE, BUJE O ARANDELA	No. de Parte	Ubicación	
				Nominal	Bore					Stroke
CYL.	YEAR	ENGINE / APPLICATION					BEARING, BUSHING OR THURST WASHER	Part Number		
				mm	Pulgadas	mm	Pulgadas			
V8	1954-55	239 (3.9L) OHV (3914 cc) B500, B600, Crestline, E600, F100, F250, F350, F500, F600, Mainline		88.90 3.500		78.74 3.100				
	1954-55	256 (4.1L) OHV (4193 cc) B600, B700, Crestline, Custom, F600, F700, Mainline, Monterey		92.08 3.625		78.74 3.100				
	1955-58	272 (4.5L) OHV (4455 cc) B600, B700, C500, C600, C700, Country Sedan, Country Squire, Custom, F100, F250, F350, F600, F700, F750, Fairlane, Mainline, P350, P400, P500, Ranch Wagon, T700		92.08 3.625		83.82 3.300				
	1955-64	292 (4.8L) OHV (4782 cc) B600, B700, C550, C600, C700, Colony Park, Country Sedan, Country Squire, Custom, F100, F250, F350, F500, F600, F700, Fairlane, Galaxie, Mainline, Meteor, Montclair, Monterey, N500, N600, N700, P350, P400, P500, Ranch Wagon, Ranger, T700, T-Bird, Villager		83.74 3.297		95.25 3.750		COJINETE DE BIELA	8B461 STD 010 020 030 040	TODOS (A, B)
	1956-60	312 (5.1L) OHV (5110 cc) Country Sedan, Country Squire, Custom, Fairlane, Mainline, Medalist, Montclair, Monterey, Ranch Wagon, T-Bird		96.47 3.798		87.33 3.438				

Línea Line



24







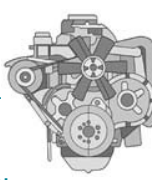
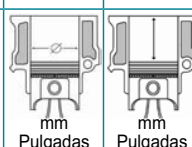
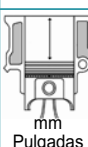



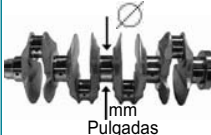



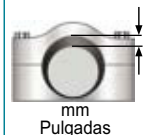









Diámetro Estándar del Muñón Standard Shaft Diameter	Diámetro Total del Alojamiento Housing Bore	Ancho del Cojinete Width Bearing	Espesor Máximo de Pared Max Wall Thickness	Claro de Lubricación Oil Clearance	Torque Torque	Imagen del Cojinete / Arandela Image of the Bearing and Thrust Washer
mm Pulgadas	mm Pulgadas	mm Pulgadas	mm Pulgadas	mm Pulgadas	N.m Lbs.Ft	
55.575/55.596 2.188/2.189	58.725/58.745 2.312/2.313	18.95 0.746	1.562 0.0615	0.0127/0.0508 0.0005/0.0020	61 a 68 N.m 45 a 50 Lbs.Ft	 <p>A</p> <p>8 Piezas</p>  <p>B</p> <p>8 Piezas</p>

FORD

MORESA!

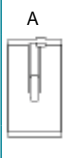
FORD LINCOLN MERCURY



CIL.	AÑO	MOTOR / APLICACIÓN		Diámetro del Cilindro Nominal Bore	Carrera Stroke	COJINETE, BUJE O ARANDELA	No. de Parte	Ubicación Location
CYL.	YEAR	ENGINE / APPLICATION		 mm Pulgadas	 mm Pulgadas	BEARING, BUSHING OR THURST WASHER	Part Number	
25	V8							
	1991-05	281 (4.6L) SOHC 16 valve	90.20	89.99	COJINETE DE BIELA	8B1442 STD 010 020 030 040	TODOS	
	1995-03	281 (4.6L) SOHC CNG 16 valve	3.551	3.543				
	1997-98	281 (4.6L) SOHC LPG 16 valve						
	1993-04	281 (4.6L) DOHC 32 valve (Triton)	COJINETE DE BANCADA Para 1996-04 VIN 6 y 1997-04 VIN code X	COJINETE DE BANCADA 1991-05 281 SOHC 16 valve 1995-03 281 SOHC CNG 16 valve 1997-98 281 SOHC LPG 16 valve Para 1993-04 VIN W (Motor Romeo)	COJINETE DE BANCADA 5C2007 STD 010 020 030 040	2-3-4-5 (B, C)		
	2003-04	281 (4.6L) DOHC 32 valve Supercharged / Intercooled (Triton) (4600 cc) Cougar, Crown Victoria, E150, E250, E350, Expedition, Explorer, F150, F250, Grand Marquis, Mountaineer, Mustang, T-Bird, Towncar				1 (A, B)		
5 (D, E)								
1-2-3-4 (A, B)								
26	V8							
	1997-05	330 (5.4L) SOHC 16 valve (Triton)	90.20 3.551	105.79 4.165	COJINETE DE BIELA	8B1442 STD 010 020 030 040	TODOS	
	1997-05	330 (5.4L) SOHC CNG 16 valve (Triton)						
	1999-05	330 (5.4L) SOHC Supercharged 16 valve (Triton)	COJINETE DE BANCADA Para 1996-04 VIN 6 y 1997-04 VIN X	COJINETE DE BANCADA 5C7296 STD 010 020 030	2-3-4-5 (B, C)			
	1998-05	330 (5.4L) SOHC Bi-Fuel 16 valve (Triton) (5400 cc) E150, E250, E350, Excursion, Expedition, F150, F250, F350, Navigator			1 (A, B,)			
5 (D, E)								

Diámetro Estándar del Muñón Standard Shaft Diameter	Diámetro Total del Alojamiento Housing Bore	Ancho del Cojinete Width Bearing	Espesor Máximo de Pared Max Wall Thickness	Claro de Lubricación Oil Clearance	Torque Torque	Imagen del Cojinete / Arandela Image of the Bearing and Thrust Washer
						
mm Pulgadas	mm Pulgadas	mm Pulgadas	mm Pulgadas	mm Pulgadas	N.m Lbs.Ft	
52.984/53.002 2.086/2.087	56.866/56.886 2.239/2.240	20.98 0.826	1.928 0.0759	0.0279/0.0584 0.0011/0.0023	31 N.m + 90° 23 Lbs.Ft + 90°	 12 Piezas
67.483/67.503 2.657/2.658	72.403/72.420 2.850/2.851	19.80 0.780	2.443 0.0962	0.0127/0.0635 0.0005/0.0025	33 N.m + 90°	     1 Pza. 5 Pzas. 4 Pzas. 2 Pza. 1 Pza.
67.483/67.503 2.657/2.658	72.403/72.420 2.850/2.851	19.00 0.748	2.443 0.0962	0.0127/0.0635 0.0005/0.0025	24 Lbs.Ft + 90°	
			2.924 0.1151			
67.483/67.503 2.657/2.658	72.403/72.420 2.850/2.851	18.29 0.720	2.443 0.0962	0.0127/0.0635 0.0005/0.0025	33 N.m + 90°	    5 Pzas. 4 Pzas. 1 Pza. 1 Pza.
67.483/67.503 2.657/2.658	72.403/72.420 2.850/2.851	22.61 0.890	2.438 0.0960	0.0127/0.0635 0.0005/0.0025	24 Lbs.Ft + 90°	
67.483/67.503 2.657/2.658	72.403/72.420 2.850/2.851	18.34 0.722	2.443 0.0962	0.0127/0.0635 0.0005/0.0025	33 N.m + 90°	    4 Pzas. 4 Pzas. 1 Pza. 1 Pza.
67.483/67.503 2.657/2.658	72.403/72.420 2.850/2.851	22.61 0.890	2.443 0.0962	0.0127/0.0635 0.0005/0.0025	24 Lbs.Ft + 90°	
52.984/53.002 2.086/2.087	56.866/56.886 2.239/2.240	20.98 0.826	1.928 0.0759	0.0279/0.0584 0.0011/0.0023	31 N.m + 90° 23 Lbs.Ft + 90°	 12 Piezas
67.483/67.503 2.657/2.658	72.403/72.420 2.851/2.851	19.80 0.780	2.443 0.0962	0.0127/0.0635 0.0005/0.0025	33 N.m + 90°	     1 Pza. 5 Pzas. 4 Pzas. 2 Pza. 1 Pza.
67.483/67.503 2.657/2.658	72.403/72.420 2.851/2.851	19.00 0.748	2.443 0.0962	0.0127/0.0635 0.0005/0.0025	24 Lbs.Ft + 90°	
			2.924 0.1151			

FORD

MORESA

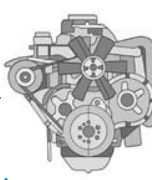
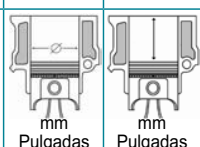
FORD LINCOLN MERCURY

CIL.	AÑO	MOTOR / APLICACIÓN			Diámetro del Cilindro Nominal Bore	Carrera Stroke	COJINETE, BUJE O ARANDELA	No. de Parte	Ubicación Location
CYL.	YEAR	ENGINE / APPLICATION			mm Pulgadas	mm Pulgadas	BEARING, BUSHING OR THURST WASHER	Part Number	
V8	1964-78	330 (5.4L) OHV (5400 cc) B500, B600, B700, C550, C600, C700, F500, F600, F700, LN500, LN600, LN700, LNT800, LT800, LTS800, N600, N700, T700	98.43 3.875	88.90 3.500	COJINETE DE BIELA	8B760 STD 010 020 030 040	TODOS		
	1958-59	332 (5.4L) OHV (5438 cc) Corsair, Country Sedan, Country Squire, Custom, Fairlane, Ranch Wagon, Ranger, T-Bird, Villager	101.60 4.000	83.82 3.300					
	1964-67	352 (5.7L) OHV (5765 cc) F100, F250, F350, Fairlane	101.60 4.000	88.90 3.000	COJINETE DE BANCADA	5C685 STD 010 020 030 040	1-2-4-5 (A)		
	1958-63	352 (5.8L) OHV (5765 cc) Colony Park, Country Sedan, Country Squire, Custom, Del Rio, F100, F250, F350, Fairlane, Galaxie, Monterey, Ranch Wagon, Ranger, T-Bird, Villager	101.60 4.000	88.90 3.500					
	1964-78	361 (5.9L) OHV (5900 cc) B600, B700, B750, C600, C700, C750, C800, F600, F700, F750, F800, L800, LN600, LN700, LN750, LN800, LNT800, LT800, LTS800, N600, N700, N1000, T700, T800	102.87 4.050	88.90 3.500				3 (B)	
	1958-59	361 (5.9L) OHV (5913 cc) Bermuda, Pacer, Ranger, Round Up	102.87 4.050	88.90 3.500	COJINETE DE BANCADA	5C445 STD 010 020 030	1-2-4-5 (A)		
	1961-63	390 (6.4L) OHV (6388 cc) Calienta, Capri, Colony Park, Comet, Commuter, Country Sedan, Custom, Cyclone, F100, F150, F250, F350, Fairlane, Galaxie, LTD, M400, M450, M500, Marauder, Marquis, Montego, Monterey, Mustang, P550, Parklane, T-Bird, Torino, Villager, Voyager	102.87 4.050	96.01 3.780				3 (B)	
	1964-76	390 (6.4L) OHV (6400 cc) Calienta, Capri, Colony Park, Comet, Commuter, Country Sedan, Custom, Cyclone, F150, F250, F350, Fairlane, Galaxie, M400, M450, M500, P550, Marauder, Marquis, Montego, Monterey, Mustang, Parklane, Rancho, Villager, Voyager	102.87 4.050	96.01 3.780	BUJE DE ARBOL	MO1445M STD 010	1		
	1964-78	391 (6.4L) OHV 6400 cc C800, F750, F800, L800, LN750, LN800, LNT800, LT800, LTS800, N1000, T800	102.87 4.050	96.27 3.790			2		
							3		
							4		
							5		



Línea Line
27

Diámetro Estándar del Muñón Standard Shaft Diameter	Diámetro Total del Alojamiento Housing Bore	Ancho del Cojinete Width Bearing	Espesor Máximo de Pared Max Wall Thickness	Claro de Lubricación Oil Clearance	Torque Torque	Imagen del Cojinete / Arandela Image of the Bearing and Thrust Washer
61.925/61.946 2.438/2.439	65.804/65.824 2.591/2.592	18.64 0.734	1.925 0.0758	0.0025/0.0635 0.0001/0.0025	33 a 61 N.m 40 a 45 Lbs.Ft	 16 Piezas
69.809/69.830 2.748/2.749	74.706/74.727 2.941/2.942	23.16 0.912	2.438 0.0960	0.0127/0.0812 0.0005/0.0032	129 a 142 N.m 95 a 105 Lbs.Ft	 8 Piezas
69.809/69.830 2.748/2.749	74.706/74.727 2.941/2.942	28.47 1.118	2.438 0.0960	0.0127/0.0812 0.0005/0.0032		 2 Piezas
69.809/69.830 2.748/2.749	74.706/74.726 2.941/2.942	23.16 0.912	2.441 0.0961	0.0127/0.0660 0.0005/0.0026	129 a 142 N.m 95 a 105 Lbs.Ft	 8 Piezas
69.809/69.830 2.748/2.749	74.706/74.726 2.941/2.942	28.47 1.121	2.441 0.0961	0.0127/0.0660 0.0005/0.0026		 2 Piezas
53.945/53.970 2.124/2.125	58.661/58.687 2.310/2.311	15.88 0.625	2.319 0.0913	0.0254/0.1270 0.0010/0.0050		1 Pieza
53.945/53.970 2.124/2.125	58.280/58.306 2.295/2.296	15.88 0.625	2.136 0.0841	0.0254/0.1270 0.0010/0.0050		1 Pieza
53.945/53.970 2.124/2.125	57.899/57.925 2.280/2.281	15.75 0.620	1.946 0.0766	0.0254/0.1270 0.0010/0.0050		1 Pieza
53.945/53.970 2.124/2.125	57.518/57.544 2.265/2.266	15.75 0.620	1.755 0.0691	0.0254/0.1270 0.0010/0.0050		1 Pieza
53.945/53.970 2.124/2.125	57.137/57.163 2.250/2.251	14.22 0.560	1.565 0.0616	0.0254/0.1270 0.0010/0.0050		1 Pieza





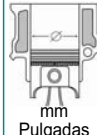
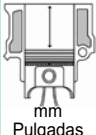





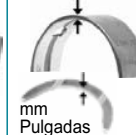
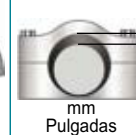

FORD

MORESA!

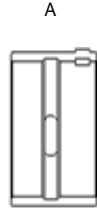
FORD LINCOLN MERCURY

CIL.	AÑO	MOTOR / APLICACIÓN		Diámetro del Cilindro Nominal Bore	Carrera Stroke	COJINETE, BUJE O ARANDELA	No. de Parte	Ubicación Location
CYL.	YEAR	ENGINE / APPLICATION		 mm Pulgadas	 mm Pulgadas	BEARING, BUSHING OR THURST WASHER	Part Number	
V8	1969-86	335 (5.5L) MÉXICO (5500 cc)	99.06 3.900	89.05 3.506	COJINETE DE BIELA	8B831 STD 010 020 030 040 050 060	→ 1 2 3 4 5 TODOS	
	1969-99	351W (5.8L) (5800 cc) Bronco, Continental, Cougar, Crown Victoria, Custom, Cyclone, E100, E150, E250, E350, F100, F150, F250, F350, Fairlane, Falcon, Galaxie, Gran Torino, Grand Marquis, LTD, LTD II, Mark VI, Marquis, Monarch, Montego, Mustang, Ranchero, T-Bird, Torino, Versailles	101.60 4.000	88.90 3.500				COJINETE DE BANCADA 1969-76
					3 (B)			
					COJINETE DE BANCADA 1977-98	5C1432 STD 010 020 030 040	1-2-4-5 (A. B)	
	3 (C, D)							
BUJE DE ARBOL 1969-98 351W OHV	MO1204M STD 010 020 030 040	1						
		2						
		3						
		4						
		5						



Línea Line
28

Diámetro Estándar del Muñón Standard Shaft Diameter	Diámetro Total del Alojamiento Housing Bore	Ancho del Cojinete Width Bearing	Espesor Máximo de Pared Max Wall Thickness	Claro de Lubricación Oil Clearance	Torque Torque	Imagen del Cojinete / Arandela Image of the Bearing and Thrust Washer
						
mm Pulgadas	mm Pulgadas	mm Pulgadas	mm Pulgadas	mm Pulgadas	N.m Lbs.Ft	
58.682/58.702 2.310/2.311	61.633/61.653 2.426/2.427	18.44 0.726	1.466 0.0577	0.0050/0.0609 0.0002/0.0024	54 a 61 N.m 40 a 45 Lbs.Ft	 16 Piezas
76.185/76.205 2.999/3.000	81.082/81.102 3.192/3.193	21.34 0.840	2.438 0.0960	0.0381/0.0990 0.0015/0.0039	129 a 142 N.m Tornillos 1/2" 47 a 61 N.m Tornillos 3/8"	 A  B 8 Piezas 2 Piezas
76.185/76.205 2.999/3.000	81.082/81.102 3.192/3.193	28.78 1.133	2.438 0.0960	0.0381/0.0990 0.0015/0.0039	95 a 105 Lbs.Ft Tornillos 1/2" 35 a 45 Lbs.Ft Tornillos 3/8"	 A  B  C  D 4 Pzas. 4 Pzas. 1 Pza. 1 Pza.
76.185/76.205 2.999/3.000	81.082/81.102 3.192/3.193	28.78 1.133	2.438 0.0960	0.0127/0.0736 0.0005/0.0029	129 a 142 N.m Tornillos 1/2" 47 a 61 N.m Tornillos 3/8"	
52.845/52.870 2.081/2.082	55.956/56.007 2.203/2.205	16.76 0.660	1.529 0.0602	0.0254/0.1270 0.0010/0.0050		1 Pieza
52.464/52.489 2.066/2.067	55.575/55.626 2.188/2.190	16.76 0.660	1.529 0.0602	0.0254/0.1270 0.0010/0.0050		1 Pieza
52.083/52.108 2.051/2.052	55.194/55.245 2.173/2.175	16.76 0.660	1.529 0.0602	0.0254/0.1270 0.0010/0.0050		1 Pieza
51.702/51.727 2.036/2.037	54.813/54.864 2.158/2.160	16.76 0.660	1.529 0.0602	0.0254/0.1270 0.0010/0.0050		1 Pieza
51.321/51.346 2.021/2.022	54.432/54.483 2.143/2.145	16.76 0.660	1.529 0.0602	0.0254/0.1270 0.0010/0.0050		1 Pieza





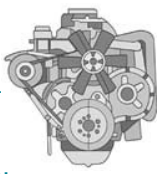

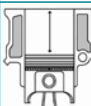

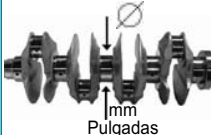

FORD

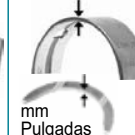
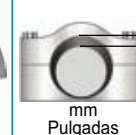
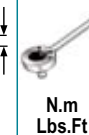
MORESA

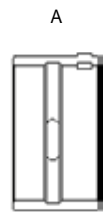
FORD LINCOLN MERCURY

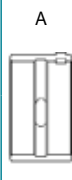
CIL.	AÑO	MOTOR / APLICACIÓN		Diámetro del Cilindro Nominal Bore	Carrera Stroke	COJINETE, BUJE O ARANDELA	No. de Parte	Ubicación
				 mm Pulgadas	 mm Pulgadas	BEARING, BUSHING OR THURST WASHER		Part Number
V8	1975-82	351M (5.8L) OHV (5800 cc) Bronco, Cougar, E100, E150, E250, E300, F100, F150, F250, F350, Gran Torino, Granada, LTD, LTD II, Marquis, Monarch, Montego, Ranchero, T-Bird	101.60 4.000	88.90 3.500	COJINETE DE BIELA	8B927 STD 010 020 030 040	TODOS	
	1971-82	400 (6.6L) OHV (6600 cc) Bronco, Continental, Cougar, Custom, E250, E350, F100, F150, F350, Galaxie, Gran Torino, Grand Marquis, LTD, LTD II, Mark V, Marquis, Montego, Monterey, Ranchero, T-Bird, Torino	101.60 4.000	101.60 4.000	COJINETE DE BANCADA 1971-76	5C981 STD 010	1-2-4-5 (A)	
					COJINETE DE BANCADA 1977-82	5C1432 STD 010 020 030 040	3 (B)	
							1-2-4-5 (A, B)	
BUJE DE ARBOL 1971-82	MO1403M STD 010 020 030	1 2 3 4 5						



Línea
Line
29

Diámetro Estándar del Muñón Standard Shaft Diameter	Diámetro Total del Alojamiento Housing Bore	Ancho del Cojinete Width Bearing	Espesor Máximo de Pared Max Wall Thickness	Claro de Lubricación Oil Clearance	Torque Torque	Imagen del Cojinete / Arandela Image of the Bearing and Thrust Washer
						
mm Pulgadas	mm Pulgadas	mm Pulgadas	mm Pulgadas	mm Pulgadas	N.m Lbs.Ft	
58.682/58.702 2.310/2.311	61.877/61.897 2.436/2.437	18.44 0.726	1.588 0.0625	0.0127/0.0609 0.0005/0.0024	54 a 61 N.m 40 a 45 Lbs.Ft	 16 Piezas
76.185/76.205 2.999/3.000	81.082/81.102 3.192/3.193	21.34 0.840	2.438 0.0960	0.0381/0.0990 0.0015/0.0039	129 a 142 N.m Tornillos 1/2" 47 a 61 N.m Tornillos 3/8"	 A  B 8 Piezas 2 Piezas
76.185/76.205 2.999/3.000	81.082/81.102 3.192/3.193	28.78 1.133	2.438 0.0960	0.0381/0.0990 0.0015/0.0039	95 a 105 Lbs.Ft Tornillos 1/2" 35 a 45 Lbs.Ft Tornillos 3/8"	 A  B  C  D 4 Pzas. 4 Pzas. 1 Pza. 1 Pza.
76.185/76.205 2.999/3.000	81.082/81.102 3.192/3.193	28.78 1.133	2.438 0.0960	0.0127/0.0736 0.0005/0.0029	129 a 142 N.m Tornillos 1/2" 47 a 61 N.m Tornillos 3/8"	
53.945/53.970 2.124/2.125	57.125/57.175 2.249/2.251	16.89 0.665	1.565 0.0616	0.0127/0.1143 0.0005/0.0045		1 Pieza
52.464/52.489 2.066/2.067	55.575/55.626 2.188/2.190	16.76 0.660	1.529 0.0602	0.0254/0.1270 0.0010/0.0050		1 Pieza
52.083/52.108 2.051/2.052	55.194/55.245 2.173/2.175	16.76 0.660	1.529 0.0602	0.0254/0.1270 0.0010/0.0050		1 Pieza
51.702/51.727 2.036/2.037	54.813/54.864 2.158/2.160	16.76 0.660	1.529 0.0602	0.0254/0.1270 0.0010/0.0050		1 Pieza
51.321/51.346 2.021/2.022	54.432/54.483 2.143/2.145	16.76 0.660	1.529 0.0602	0.0254/0.1270 0.0010/0.0050		1 Pieza

FORD

MORESA!

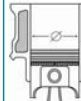
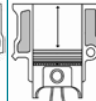
FORD LINCOLN MERCURY

CIL.	AÑO	MOTOR / APLICACIÓN		Diámetro del Cilindro Nominal Bore	Carrera Stroke	COJINETE, BUJE O ARANDELA	No. de Parte	Ubicación Location
CYL.	YEAR	ENGINE / APPLICATION		 mm Pulgadas	 mm Pulgadas	BEARING, BUSHING OR THURST WASHER	Part Number	
V8	1973-78	359 (5.9L) OHV (5900 cc) B600, B700, B750, C600, C700, C750, L800, LN600, LN700, LN750, LNT800, LT800, LTS800	102.87 4.050	88.90 3.500	COJINETE DE BIELA	8B760 STD 010 020 030 040	1 2 3 4 5	
	1966-67	410 (6.7L) OHV (6715 cc) Commuter, Colony Park, Marquis, Monterey, Parklane	102.87 4.050	101.09 3.980				
	1968	427 (7.0L) OHV (6994 cc) Cougar, Custom, Cyclone, Montego, Mustang	107.52 4.233	96.01 3.780				
	1975-78	428 (7.0L) OHV (7000 cc) Colony Park, Commuter, Cougar, Country Sedan, Cyclone, Fairlane, Galaxie, Marquis, Montego, Mustang, Parklane, Rancho, S55, T-Bird, Torino	104.90 4.130	101.09 3.980	BUJE DE ARBOL	MO1445M STD 010	1	
	1966-70	428 (7.0L) OHV (7010 cc) Colony Park, Commuter, Cougar, Country Sedan, Cyclone, Fairlane, Galaxie, Marquis, Montego, Mustang, Parklane, Rancho, S55, T-Bird, Torino	104.90 4.130	101.09 3.980			2	
							3	
							4	
							5	

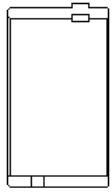

Línea Line
30

Diámetro Estándar del Muñón Standard Shaft Diameter	Diámetro Total del Alojamiento Housing Bore	Ancho del Cojinete Width Bearing	Espesor Máximo de Pared Max Wall Thickness	Claro de Lubricación Oil Clearance	Torque Torque	Imagen del Cojinete / Arandela Image of the Bearing and Thrust Washer
mm Pulgadas	mm Pulgadas	mm Pulgadas	mm Pulgadas	mm Pulgadas	N.m Lbs.Ft	
61.925/61.946 2.438/2.439	65.804/65.824 2.591/2.592	18.64 0.734	1.925 0.0758	0.0025/0.0635 0.0001/0.0025	54 a 61 N.m 40 a 45 Lbs.Ft	 16 Piezas
53.945/53.970 2.124/2.125	58.661/58.687 2.310/2.311	15.88 0.625	2.319 0.0913	0.0254/0.1270 0.0010/0.0050		1 Pieza
53.945/53.970 2.124/2.125	58.280/58.306 2.295/2.296	15.88 0.625	2.136 0.0841	0.0254/0.1270 0.0010/0.0050		1 Pieza
53.945/53.970 2.124/2.125	57.899/57.925 2.280/2.281	15.75 0.620	1.946 0.0766	0.0254/0.1270 0.0010/0.0050		1 Pieza
53.945/53.970 2.124/2.125	57.518/57.544 2.265/2.266	15.75 0.620	1.755 0.0691	0.0254/0.1270 0.0010/0.0050		1 Pieza
53.945/53.970 2.124/2.125	57.137/57.163 2.250/2.251	14.22 0.560	1.565 0.0616	0.0254/0.1270 0.0010/0.0050		1 Pieza

FORD

MORESA

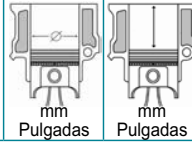
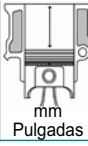
FORD LINCOLN MERCURY

CIL.	AÑO	MOTOR / APLICACIÓN		Diámetro del Cilindro Nominal Bore	Carrera Stroke	COJINETE, BUJE O ARANDELA	No. de Parte	Ubicación Location
CYL.	YEAR	ENGINE / APPLICATION		 mm Pulgadas	 mm Pulgadas	BEARING, BUSHING OR THURST WASHER	Part Number	
31	V8							
	1979-91	370 (6.1L) OHV (6100 cc) B700, C600, C700, C800, F600, F700, F800, FT800, L800, LN600, LN700, LN800, LNT800, LT800, LTS800	102.79 4.047	91.19 3.590	COJINETE DE BIELA	8B818 STD 010 020 030 040	TODOS	
	1979-98	429 (7.0L) OHV Truck (7000 cc) B700, C700, C800, F600, F700, F800, FT800, L800, LN600, LN700, LN800, LNT800, LT800, LTS800	110.74 4.360	91.19 3.590	COJINETE DE BANCADA	5C1039 STD 010 020 030 040	1-2-4-5 (A, B)	
	1968-73	429 (7.0L) OHV Pass. (7027 cc) Cougar, Custom, Cyclone, LTD, Marauder, Marquis, Montego, Monterey, Mustang, Rancho, T-Bird, Torino	110.74 4.360	91.19 3.590			3 (C)	
	1968-98	460 (7.5L) OHV (7500 cc) Continental, Cougar, E250, E350, F-Super Duty, F100, F150, F250, F350, F53, Gran Torino, Grand Marquis, LTD, M450, Mark V, Mark IV, Mark III, Marquis, Montego, Monterey, Rancho, Torino	107.4 4.360	97.79 3.850	BUJE DE ARBOL	MO1414M STD	1-2-3-4-5	
32	V10							
1997-06	415 (6.8L) SOHC 20 valve (Triton) (6800 cc) E250, E350, E450, Excursion, F250, F350, F450, F550	90.22 3.552	106.40 4.189	COJINETE DE BIELA	10B1442 STD 010 020 030	TODOS		
				COJINETE DE BANCADA	6C7297 STD 010 020 030	2-3-4-5-6 (B, C)		
			1 (A, B)					
			6 (D, E)					

Diámetro Estándar del Muñón Standard Shaft Diameter	Diámetro Total del Alojamiento Housing Bore	Ancho del Cojinete Width Bearing	Espesor Máximo de Pared Max Wall Thickness	Claro de Lubricación Oil Clearance	Torque Torque	Imagen del Cojinete / Arandela Image of the Bearing and Thrust Washer
63.480/63.500 2.499/2.500	67.366/67.386 2.652/2.653	22.00 0.866	1.933 0.0761	0.0127/0.0787 0.0005/0.0035	54 a 61 N.m 40 a 45 Lbs.Ft	 16 Piezas
76.185/76.205 2.999/3.000	81.082/81.102 3.192/3.193	24.13 0.950	2.433 0.0958	0.0177/0.0838 0.0007/0.0033	129 a 142 N.m	A B C
76.185/76.205 2.999/3.000	81.082/81.102 3.192/3.193	28.45 1.120	2.433 0.0958	0.0177/0.0838 0.0007/0.0033	95 a 105 Lbs.Ft	4 Piezas 4 Piezas 2 Piezas
53.945/53.970 2.124/2.125	57.137/57.163 2.250/2.251	14.86 0.585	1.575 0.0620	0.0254/0.1270 0.0010/0.0050		5 Piezas
52.984/53.002 2.086/2.087	56.866/56.886 2.239/2.240	20.98 0.826	1.928 0.0759	0.0279/0.0584 0.0011/0.0023	41 a 45 N.m + 90 a 120° 30 a 33 Lbs.Ft + 90 a 120°	 20 Piezas
67.483/67.503 2.657/2.658	72.403/72.420 2.850/2.851	19.80 0.780	2.443 0.0962	0.0127/0.0635 0.0005/0.0025	30 a 34 N.m + 85 a 95°	A B C D E
67.483/67.503 2.657/2.658	72.403/72.420 2.850/2.851	19.00 0.748	2.443 0.0962	0.0127/0.0635 0.0005/0.0025	22 a 25 Lbs.Ft + 85 a 95°	1 Pza. 6 Pzas. 5 Pzas. 2 Pza. 1 Pza.
			2.924 0.1151			

GM CHEVROLET



GM CHEVROLET BUICK OLDSMOBILE PONTIAC

4 CILINDROS / 4 CYLINDER		
MOTOR / ENGINE	AÑO / YEAR	LINEA / LINE
1.4 L	1982-02	1
85 (1.4L) Chevrolet SOHC 8 valve	1976-77	2
1.6 L	1982-02	1
C 16 NZ/E 16 SE /X 16 SZR (1.6L)		1
X 16 XE/XEL (1.6L)		1
98 (1.6L) Chevrolet SOHC 8 valve	1976-87	2
97 (1.6L) Toyota SOHC 8 valve	1985-89	3
97 (1.6L) Toyota SOHC 16 valve	1988-89	3
1.8L (1.8L) Block aluminio		4
111 (1.8L) Isuzu SOHC 8 valve	1972-82	5
112 (1.8L) Chevrolet OHV	1982	6
119 (1.9L) Isuzu SOHC 8 valve LR1	1982-85	5
121 (2.0L) OHV LL8 Type 1	1987-89	6
121 (2.0L) OHV Types B,P	1983-86	6
121 (2.0L) OHV Type Y	1983-84	6
121 (2.0L) OHV LL8	1987-89	7
122 (2.0L) Chevrolet (Cosworth) DOHC 16 valve	1975-77	6
140 (2.3L) Chevrolet SOHC 8 valve	1971-77	6
153 (2.5L) Chevrolet OHV	1962-70	6
134 (2.2L) OHV Types G,4	1990-97	7
134 (2.2L) L61 DOHC ECOTEC	2000-05	8
134 (2.2L) L42 DOHC ECOTEC	2003	8
2.2L (2.2L) DOHC ECOTEC 16 valve	2001-03	8
138 (2.3L) Oldsmobile SOHC 8 valve	1992-94	9
138 (2.3L) Oldsmobile DOHC 16 valve	1987-96	9
146 (2.4L) DOHC Oldsmobile, LD9,16 valve	1996-02	10
151 (2.5L) Pontiac OHV	1977-84	11
151 (2.5L) Pontiac OHV Vin "R", "2"	1985-92	11
151 (2.5L) Pontiac OHV Vin "A", "E"	1985-93	11

6 CILINDROS / 6 CYLINDER		
MOTOR / ENGINE	AÑO / YEAR	LINEA / LINE
173 (2.8L) Chevrolet OHV, First Design	1980-85	12
173 (2.8L) Chevrolet OHV, Second Design	1985-93	12
173 (2.8L) Chevrolet LPG	1987-89	13
173 (2.8L) Chevrolet Meth	1987-89	13
181 (3.0L) Buick OHV	1982-88	14
191 (3.1L) Types D,M,T,W,V6	1988-05	13
191 (3.1L) Chevrolet Turbo OHV	1989-90	13
194 (3.2L) Chevrolet OHV	1962-67	15
196 (3.2L) Buick OHV	1964-77	16
200 (3.3L) Chevrolet OHV	1978-79	17
204 (3.3L) Buick OHV	1988-93	18
207 (3.4L) OHV Type S	1993-03	19
207 (3.4L) DOHC 24 valve Type X	1991-97	19
207 (3.4L) OHV Type S	1993-03	13
207 (3.4L) DOHC 24 valve Type X	1991-97	13
215 (3.5L) Pontiac OHV	1964-65	15
225 (3.7L) Buick OHV	1964-77	20
229 (3.8L) Chevrolet OHV (K)	1980-84	17
230 (3.8L) Chevrolet OHV	1962-70	15
230 (3.8L) Pontiac SOHC 12 valve	1966-67	15
231 (3.8L) Buick Turbo OHV	1978-89	14
231 (3.8L) Buick OHV, Vin "C", "L", Series I	1988-95	21
231 (3.8L) Buick OHV, Vin "K", Series II	1995-04	21
231 (3.8L) Buick Supercharged OHV, Vin "1"	1991-04	21
231 (3.8L) Buick OHV, Exc. 3800 Series I and II	1975-88	21
231 (3.8L) Buick OHV, Vin "C", "L", Series I	1988-95	21
231 (3.8L) Buick OHV Type K 3800 Series II	1995-05	21
231 (3.8L) Buick Supercharged OHV, Vin "1"	1991-05	21
231 (3.8L) Type 1 Supercharged 3800 Series II	1996-99	21
235 (3.8L) Chevrolet OHV	1953-62	22
250 (4.1L) Pontiac SOHC 12 valve	1968-69	23
250 (4.1L) Chevrolet OHV	1966-84	23
250 (4.1L) Chevrolet OHV	1994-98	23
252 (4.1L) Buick OHV	1980-84	16
261 (4.2L) Chevrolet OHV	1954-62	22
261 (4.3L) Chevrolet OHV	1954-62	22
262 (4.3L) Chevrolet exc. High Output, OHV	1985-06	25
262 (4.3L) Chevrolet High Output OHV Vin "B" LU4	1990-91	25
262 (4.3L) Chevrolet Turbo OHV Vin "Z" LB4	1991-93	25
292 (4.8L) Chevrolet OHV Vin "T"	1963-90	26



GM CHEVROLET BUICK OLDSMOBILE PONTIAC







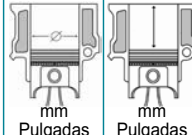
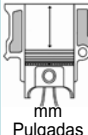



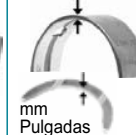
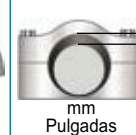

8 CILINDROS / 8 CYLINDER		
MOTOR / ENGINE	AÑO / YEAR	LINEA / LINE
252 (4.1L) Cadillac OHV	1982-88	24
260 (4.3L) Oldsmobile OHV	1975-82	27
262 (4.3L) Chevrolet OHV Vin "G"	1975-76	28
265 (4.3L) Chevrolet L99 OHV Vin "W"	1994-96	28
265 (4.3L) Pontiac OHV Vin "S"	1980-81	29
267 (4.4L) Chevrolet OHV Vin "J"	1979-82	28
273 (4.5L) Cadillac OHV	1988-92	24
283 (4.6L) Chevrolet OHV	1957-67	30
293 (4.8L) Chevrolet Vortec OHV Gen III	1999-06	31
300 (4.9L) Cadillac OHV	1991-95	24
300 (4.9L) Buick OHV	1964-67	32
301 (4.9L) Pontiac OHV	1977-81	29
301 (4.9L) Pontiac Turbo OHV	1980-81	29
302 (4.9L) Chevrolet OHV	1967-69	33
305 (5.0L) Chevrolet OHV	1976-99	28
307 (5.0L) Chevrolet OHV	1968-73	28
307 (5.0L) Oldsmobile OHV	1980-90	34
325 (5.3L) Chevrolet Vortec OHV Gen III	1999-06	31
327 (5.4L) Chevrolet OHV Vin "L"	1968-69	28
327 (5.4L) Chevrolet OHV	1962-69	33
330 (5.4L) Oldsmobile OHV , Second Series Vin "O"	1964-67	35
340 (5.6L) Buick OHV Vin "B"	1966-67	32
346 (5.7L) Chevrolet LS1 Vortec OHV Gen III	1997-04	31
346 (5.7L) Chevrolet LS6 Vortec OHV Gen III	2001-06	31
348 (5.7L) Chevrolet OHV	1958-65	36
350 (5.7L) Buick OHV Type B	1968-81	29
350 (5.7L) Oldsmobile OHV	1968-80	27
350 (5.7L) Chevrolet OHV, Inc. LT1, Exc. DOHC	1967-02	33
365 (6.0L) Chevrolet Vortec OHV Gen III	1999-06	31
366 (6.0L) Chevrolet OHV	1966-00	37
396 (6.5L) Chevrolet OHV	1965-70	37
400 (6.6L) Chevrolet OHV	1970-80	38
402 (6.6L) Chevrolet OHV	1970-72	37
403 (6.6L) Oldsmobile OHV	1977-79	39
427 (7.0L) Chevrolet OHV	1966-00	37
454 (7.4L) Chevrolet OHV	1970-00	37
496 (8.1L) Chevrolet Vortec OHV	2001-05	40
502 (8.2L) Chevrolet Gen IV, V, VI OHV	1990-01	35

GM CHEVROLET

MORESA!

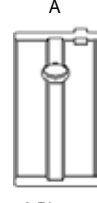

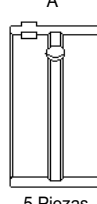
GM CHEVROLET BUICK OLDSMOBILE PONTIAC







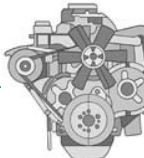
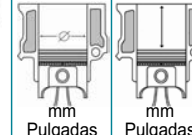
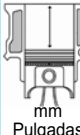

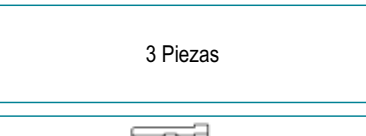
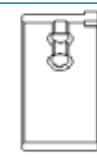

CIL.	AÑO	MOTOR / APLICACIÓN		Diámetro del Cilindro Nominal Bore	Carrera Stroke	COJINETE, BUJE O ARANDELA	No. de Parte	Ubicación Location
CYL.	YEAR	ENGINE / APPLICATION		 mm Pulgadas	 mm Pulgadas	BEARING, BUSHING OR THURST WASHER	Part Number	
1	L4	1994-03	1.4 L (1389 cc) Chevy	77.60 3.055	73.40 2.889	COJINETE DE BIELA	4B1451 STD 010 020	TODOS
		1996-08	1.6 L (1598 cc) Chevy, Chevy C2	79.00 3.110	81.50 3.208			
		C 16 NZ/E 16 SE /X 16 SZR (1.6L) (1598 cc) Corsa	79.00 3.110	81.50 3.208	COJINETE DE BANCADA	5C1545 STD 010 020 030	1-2-4-5 (A)	
		X 16 XE/XEL (1.6L) (1598 cc) Corsa	79.00 3.110	81.50 3.208			3 (B)	
2	L4	1976-77	85 (1.4L) Chevrolet SOHC 8 valve (1400 cc) Acadian, Chevette	82.00 3.228	66.19 2.606	COJINETE DE BIELA	4B1216 STD 010 020 030 040	TODOS
		1976-87	98 (1.6L) Chevrolet SOHC 8 valve (1600 cc) Acadian, Chevette	82.00 3.228	76.00 3.157			
					COJINETE DE BANCADA	5C1424 STD 010 020 030	1-2-3-4 (A)	
							5 (B)	
3	L4	1985-89	97 (1.6L) Toyota SOHC 8 valve (1587 cc) Nova	81.00 3.189	77.00 3.031	COJINETE DE BIELA	4B1361 STD 010 020 030	TODOS
		1988-89	97 (1.6L) Toyota SOHC 16 valve (1587 cc) Nova	81.00 3.189	77.00 3.031			
					COJINETE DE BANCADA	5C1638 STD 010 020 030 040	1-2-3-4-5 (A, B)	

Diámetro Estándar del Muñón Standard Shaft Diameter	Diámetro Total del Alojamiento Housing Bore	Ancho del Cojinete Width Bearing	Espesor Máximo de Pared Max Wall Thickness	Claro de Lubricación Oil Clearance	Torque Torque	Imagen del Cojinete / Arandela Image of the Bearing and Thrust Washer
						
mm Pulgadas	mm Pulgadas	mm Pulgadas	mm Pulgadas	mm Pulgadas	N.m Lbs.Ft	
42.972/42.987 1.692/1.692	45.999/46.012 1.811/1.812	16.64 0.655	1.496 0.0589	0.0177/0.0711 0.0007/0.0028	20 a 23 N.m 15 a 17 Lbs.Ft	 8 Piezas
54.973/54.986 2.164/2.165	58.999/59.012 2.323/2.323	19.56 0.770	1.991 0.0784	0.0254/0.0635 0.0010/0.0025	69 a 72 N.m	 A  B 8 Piezas 2 Piezas
54.973/54.986 2.164/2.165	58.999/59.012 2.323/2.323	25.91 1.020	1.991 0.0784	0.0254/0.0635 0.0010/0.0025	51 a 53 Lbs.Ft	
45.959/45.982 1.809/1.810	48.999/49.012 1.929/1.930	19.05 0.750	1.496 0.0589	0.0355/0.0889 0.0014/0.0035	50 N.m 37 Lbs.Ft (1976 - 77) 54 N.m 40 Lbs.Ft (1978 - 87)	 8 Piezas
51.001/51.013 2.008/2.008	54.986/55.014 2.165/2.166	18.01 0.709	1.979 0.0779	0.0228/0.0889 0.0009/0.0035	62 N.m 46 Lbs.Ft (1976 - 77)	 A  B 8 Piezas 2 Piezas
51.001/51.013 2.008/2.008	54.986/55.014 2.165/2.166	23.90 0.941	1.979 0.0779	0.0406/0.1066 0.0016/0.0042	68 N.m 50 Lbs.Ft (1978 - 87)	
39.980/40.000 1.574/1.575	43.000/43.025 1.693/1.694	17.09 0.673	1.491 0.0587	0.0177/0.0812 0.0007/0.0032	49 N.m 36 Lbs.Ft	 8 Piezas
47.981/48.001 1.889/1.890	52.019/52.045 2.048/2.049	19.89 0.783	2.004 0.0789	0.0152/0.0914 0.0006/0.0036	98 a 109 N.m 72 a 80 Lbs.Ft	 A  B 5 Piezas 5 Piezas

GM CHEVROLET

MORESA!





CIL.	AÑO	MOTOR / APLICACIÓN		Diámetro del Cilindro Nominal Bore	Carrera Stroke	COJINETE, BUJE O ARANDELA	No. de Parte	Ubicación Location
CYL.	YEAR	ENGINE / APPLICATION		 mm Pulgadas	 mm Pulgadas	BEARING, BUSHING OR THURST WASHER	Part Number	
4	L4	1.8L (1.8L) Block aluminio (1800 cc) Astra, Vectra, Zafira.				BUJE DE ARBOL	MOCHG-16 STD	1-2-3 FLECHA DERECHA 1-2-3 FLECHA IZQUIERDA
5	L4	1972-82 111 (1.8L) Isuzu SOHC 8 valve (1817 cc) Luv, S10, S15	84.00 3.307	82.00 3.228	COJINETE DE BIELA	4B1377 STD 010 020 030	TODOS	
		1982-85 119 (1.9L) Isuzu SOHC 8 valve LR1 (1949 cc) Luv, S10, S15	87.00 3.425	82.00 3.228				COJINETE DE BANCADA
					ARANDELA	AM451 STD	3	
6	L4	1982 112 (1.8L) Chevrolet OHV (1800 cc) Cavalier, Cimaron, Firenza, J2000, Skyhawk	89.00 3.504	74.00 2.913	COJINETE DE BIELA	4B745 STD 010 020 030 040 050 060	TODOS	
		1987-89 121 (2.0L) OHV LL8 Type 1 (2000 cc) Beretta, Cavailer, Corsica, Firenza, Skyhawk, Tempest	89.00 3.504	80.01 3.150				
		1983-86 121 (2.0L) OHV Types B,P (2000 cc) Cavalier, Firenza, Skyhawk	89.00 3.504	80.01 3.150				
		1983-84 121 (2.0L) OHV Type Y (2000 cc) Cavailer, Firenza, S10, S15, Skyhawk	89.00 3.504	80.01 3.150	BUJE DE ARBOL 1983-86	MO1485M STD	1 2-5 3-4	
		1975-77 122 (2.0L) Chevrolet (Cosworth) DOHC 16 valve (2000 cc) Vega	88.90 3.500	80.26 3.160				
		1971-77 140 (2.3L) Chevrolet SOHC 8 valve (2300 cc) Vega	88.90 3.500	92.08 3.625				
		1962-70 153 (2.5L) Chevrolet OHV (2506 cc) Chevy II, G10, G1000, Nova, P10, P1000	98.48 3.877	82.55 3.250				

Diámetro Estándar del Muñón Standard Shaft Diameter	Diámetro Total del Alojamiento Housing Bore	Ancho del Cojinete Width Bearing	Espesor Máximo de Pared Max Wall Thickness	Claro de Lubricación Oil Clearance	Torque Torque	Imagen del Cojinete / Arandela Image of the Bearing and Thrust Washer
mm Pulgadas	mm Pulgadas	mm Pulgadas	mm Pulgadas	mm Pulgadas	N.m Lbs.Ft	
36.748/36.730 1.4468/1.4461	40.716/40.703 1.6030/1.6025	25.65 1.010	1.973 0.0777	0.0127/0.0812 0.0005/0.0032		 3 Piezas
36.748/36.730 1.4468/1.4461	40.716/40.703 1.6030/1.6025	25.65 1.010	1.973 0.0777	0.0127/0.0812 0.0005/0.0032		 3 Piezas
48.925/48.941 1.926/1.927	51.984/51.999 2.047/2.047	21.51 0.847	1.514 0.0596	0.0304/0.1016 0.0012/0.0040	58 N.m 43 Lbs.Ft	 8 Piezas
55.921/55.936 2.202/2.202	58.979/58.999 2.322/2.323	32.13 1.265	1.514 0.0596	0.0228/0.0990 0.0009/0.0039	95 N.m	 A  B
55.921/55.936 2.202/2.202	58.979/58.999 2.322/2.323	21.11 0.831	1.514 0.0596	0.0228/0.0990 0.0009/0.0039	70 Lbs.Ft	 6 Piezas  4 Piezas
63.749/64.000 2.510/2.520	80.201/80.449 3.158/3.167		2.360 0.0929			 2 Piezas
50.775/50.800 1.999/2.000	53.967/53.980 2.125/2.125	21.39 0.842	1.577 0.0621	0.0254/0.0889 0.0010/0.0035	46 a 58 N.m 34 a 43 Lbs.Ft	 8 Piezas
47.440/47.490 1.868/1.870	51.280/51.331 2.019/2.021	15.88 0.625	1.882 0.0741	0.0381/0.1041 0.0015/0.0041		 1 Pieza
47.440/47.490 1.868/1.870	51.031/51.054 2.009/2.010	15.88 0.625	1.755 0.0691	0.0381/0.1041 0.0015/0.0041		 2 Pieza
47.440/47.490 1.868/1.870	50.770/50.805 1.999/2.000	16.00 0.630	1.626 0.064	0.0381/0.1041 0.0015/0.0041		 2 Pieza

GM CHEVROLET

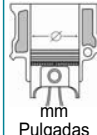
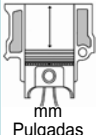





MORESA

GM CHEVROLET BUICK OLDSMOBILE PONTIAC

CIL.	AÑO	MOTOR / APLICACIÓN		Diámetro del Cilindro Nominal Bore	Carrera Stroke	COJINETE, BUJE O ARANDELA	No. de Parte	Ubicación Location
CYL.	YEAR	ENGINE / APPLICATION		 mm Pulgadas	 mm Pulgadas	BEARING, BUSHING OR THURST WASHER	Part Number	
L4	1987-89	121 (2.0L) OHV LL8 (2000 cc) Cavalier, Firenza, Skyhawk	89.00 3.504	80.00 3.150	COJINETE DE BIELA	4B745 STD 010 020 030 040 050 060		
	1990-97	134 (2.2L) OHV Types G,4 (2189 cc) Beretta, Cavalier, Century, Corsica, Cutlass, Cutlass Ciera, Lumina, S10, Sonoma, Sunfire	89.00 3.504	88.00 3.465				
					COJINETE DE BANCADA	5C1749 STD 010 020 030 040	1-2-3-5 (A)	
							4 (B)	
						BUJE DE ARBOL	MO1485M STD	1
								2-5
								3-4
L4	2000-05	134 (2.2L) L61 DOHC ECOTEC (2200 cc) Alero, Cavalier, Classic, Cobalt, Grand Am, Malibu, Pursuit, Saturn ION, Sunfire	86.00 3.386	94.60 3.724	COJINETE DE BIELA	4B1827 STD 010 020		
	2003	134 (2.2L) L42 DOHC ECOTEC (2200 cc)	86.00 3.386	94.60 3.724				
	2001-03	2.2L (2.2L) DOHC ECOTEC 16 valve (2200 cc) Astra, Vectra, Zafira.			BUJE DE ARBOL	MOCHG-16 STD	1-2-3 FLECHA DERECHA	
							1-2-3 FLECHA IZQUIERDA	

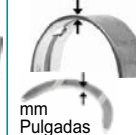
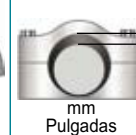
Línea Line
7

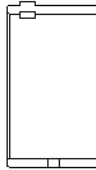

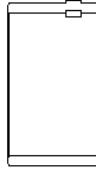

8

Diámetro Estándar del Muñón Standard Shaft Diameter	Diámetro Total del Alojamiento Housing Bore	Ancho del Cojinete Width Bearing	Espesor Máximo de Pared Max Wall Thickness	Claro de Lubricación Oil Clearance	Torque Torque	Imagen del Cojinete / Arandela Image of the Bearing and Thrust Washer
						
mm Pulgadas	mm Pulgadas	mm Pulgadas	mm Pulgadas	mm Pulgadas	N.m Lbs.Ft	
50.775/50.800 1.999/2.000	53.967/53.980 2.125/2.125	21.39 0.842	1.577 0.0621	0.0254/0.0889 0.0010/0.0035	46 a 58 N.m 34 a 43 Lbs.Ft	 8 Piezas
63.360/63.383 2.495/2.495	68.250/68.275 2.687/2.688	18.85 0.742	2.423 0.0954	0.0228/0.0990 0.0009/0.0039	95 N.m 70 Lbs.Ft	A  8 Piezas
63.360/63.383 2.495/2.495	68.250/68.275 2.687/2.688	23.93 0.942	2.423 0.0954	0.0228/0.0990 0.0009/0.0039		B  2 Piezas
47.440/47.490 1.868/1.870	51.280/51.331 2.019/2.021	15.88 0.625	1.882 0.0741	0.0381/0.1041 0.0015/0.0041		1 Pieza
47.440/47.490 1.868/1.870	51.031/51.054 2.009/2.010	15.88 0.625	1.755 0.0691	0.0381/0.1041 0.0015/0.0041		2 Pieza
47.440/47.490 1.868/1.870	50.770/50.805 1.999/2.000	16.00 0.630	1.626 0.0640	0.0381/0.1041 0.0015/0.0041		2 Pieza
49.979/50.004 1.9677/1.9687	53.042/53.058 2.0883/2.0889	20.14 0.793	1.508 0.0594	0.0101/0.0558 0.0004/0.0022	24 N.m + 90° 18 Lbs.Ft + 100°	 8 Piezas
36.748/36.730 1.4468/1.4461	40.716/40.703 1.6030/1.6025	25.65 1.010	1.973 0.0777	0.0127/0.0812 0.0005/0.0032		3 Piezas
36.748/36.730 1.4468/1.4461	40.716/40.703 1.6030/1.6025	25.65 1.010	1.973 0.0777	0.0127/0.0812 0.0005/0.0032		3 Piezas

GM CHEVROLET

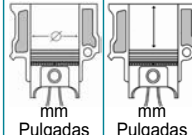
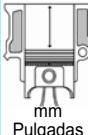











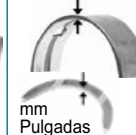
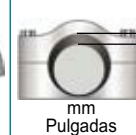

MORESA!

GM CHEVROLET BUICK OLDSMOBILE PONTIAC

CIL.	AÑO	MOTOR / APLICACIÓN		Diámetro del Cilindro Nominal Bore	Carrera Stroke	COJINETE, BUJE O ARANDELA	No. de Parte	Ubicación Location
CYL.	YEAR	ENGINE / APPLICATION		 mm Pulgadas	 mm Pulgadas	BEARING, BUSHING OR THURST WASHER	Part Number	
L4	1992-94	138 (2.3L) Oldsmobile SOHC 8 valve (2300 cc) Achieva, Grand Am, Skylark, Sunfire		91.95 3.620	85.09 3.350	COJINETE DE BIELA	4B1388 STD 010 020	TODOS
	1987-96	138 (2.3L) Oldsmobile DOHC 16 valve (2300 cc) Achieva, Beretta, Calais, Cavalier, Corsica, Cutlass, Grand Am, Grand Prix, Skyhawk, Somerset, Sunfire		92.00 3.622	85.09 3.350	COJINETE DE BANCADA	5C1703 STD 010 020	1-2-4-5 (A, B)
						BUJE DE ARBOL	MOGMG-1 STD	3 (C, D) 1-2-3-4-5
L4	1996-02	146 (2.4L) DOHC Oldsmobile, LD9, 16 valve (2400 cc) Achieva, Alero, Cavalier, Grand Am, Malibu, Skylark, Sunfire		89.99 3.543	93.98 3.700	COJINETE DE BIELA	4B1647 STD 010 020	TODOS
						COJINETE DE BANCADA	5C2056 STD 010 020	1-2-4-5 (A, B)
								BUJE DE ARBOL

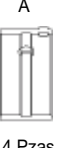



Línea Line
9

10

Diámetro Estándar del Muñón Standard Shaft Diameter	Diámetro Total del Alojamiento Housing Bore	Ancho del Cojinete Width Bearing	Espesor Máximo de Pared Max Wall Thickness	Claro de Lubricación Oil Clearance	Torque Torque	Imagen del Cojinete / Arandela Image of the Bearing and Thrust Washer
						
47.973/47.998 1.889/1.890	51.166/51.191 2.014/2.015	22.76 0.896	1.582 0.0623	0.0127/0.0508 0.0005/0.0020	24 N.m + 90° 18 Lbs.Ft + 90°	 8 Piezas
51.994/52.019 2.047/2.048	56.774/56.799 2.235/2.236	21.26 0.837	2.377 0.0936	0.0127/0.0508 0.0005/0.0020	20 N.m + 90°	 4 Pzas.
51.994/52.019 2.047/2.048	56.774/56.799 2.235/2.236	27.76 1.093	2.377 0.0936	0.0127/0.0508 0.0005/0.0020	15 Lbs.Ft + 90°	 4 Pzas.
29.974/29.959 1.180/1.180	33.050/28.699 1.301/1.130	20.19 0.795	1.506 0.0593	0.0101/0.0736 0.0004/0.0029		 1 Pza.
						 1 Pza.
47.973/47.998 1.889/1.890	51.173/51.186 2.015/2.015	18.29 0.720	1.582 0.0623	0.0228/0.0863 0.0009/0.0034	24 N.m + 90° 18 Lbs.Ft + 90°	 8 Piezas
60.010/60.030 2.363/2.363	64.775/64.800 2.550/2.551	19.99 0.787	2.377 0.0936	0.010170.0736 0.0004/0.0029	20 N.m + 90°	 4 Pzas.
60.010/60.030 2.363/2.363	64.775/64.800 2.550/2.551	27.74 1.092	2.377 0.0936	0.010170.0736 0.0004/0.0029	15 Lbs.Ft + 90°	 4 Pzas.
29.974/29.959 1.1801/1.1795	33.050/28.699 1.3012/1.1299	20.19 0.795	1.506 0.0593	0.010170.0736 0.0004/0.0029		 1 Pza.
						 1 Pza.



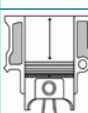



GM CHEVROLET

MORESA!

CIL.	AÑO	MOTOR / APLICACIÓN			Diámetro del Cilindro Nominal Bore	Carrera Stroke	COJINETE, BUJE O ARANDELA	No. de Parte	Ubicación Location
CYL.	YEAR	ENGINE / APPLICATION			mm Pulgadas	mm Pulgadas	BEARING, BUSHING OR THURST WASHER	Part Number	
L4	1977-84	151 (2.5L) Pontiac OHV (2500 cc) Astro, Camaro, Celebrity, Century, Citation, Firebird, Monza, Omega, Phoenix, Skylark, Starfire, Ventura	101.60 4.000	76.20 3.000	COJINETE DE BIELA	4B610 STD 010 020 030 040	TODOS		
	1985-92	151 (2.5L) Pontiac OHV Vin "R", "2" (2500 cc) 6000, Celebrity, Ciera, Citation, Fiero, Lumina, Skylark	101.60 4.000	76.20 3.000					
	1985-93	151 (2.5L) Pontiac OHV Vin "A", "E" (2500 cc) Astro, Camaro, Firebird, S10, S15, Safari, Sonoma	101.60 4.000	76.20 3.000				COJINETE DE BANCADA	5C1733 STD 010 020 030 040
					BUJE DE ARBOL	MO1461M STD	1-2-3		

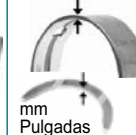
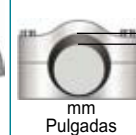
Línea Line

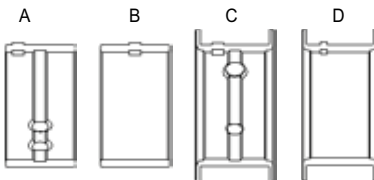

11

Diámetro Estándar del Muñón Standard Shaft Diameter	Diámetro Total del Alojamiento Housing Bore	Ancho del Cojinete Width Bearing	Espesor Máximo de Pared Max Wall Thickness	Claro de Lubricación Oil Clearance	Torque Torque	Imagen del Cojinete / Arandela Image of the Bearing and Thrust Washer
 mm Pulgadas	 mm Pulgadas	 mm Pulgadas	 mm Pulgadas	 mm Pulgadas	 N.m Lbs.Ft	
50.787/50.813 2.000/2.001	53.967/53.980 2.125/2.125	18.85 0.742	1.575 0.0620	0.0177/0.0812 0.0007/0.0032	41 N.m 30 Lbs.Ft Excepto Cabezas de Flujo Cruzado 43 N.m 32 Lbs.Ft Cabezas de Flujo Cruzado	 8 Piezas
58.377/58.402 2.298/2.299	63.261/63.287 2.491/2.492	20.50 0.807	2.426 0.0955	0.0152/0.0914 0.0006/0.0036	88 N.m 65 Lbs.Ft Excepto Cabezas de Flujo Cruzado	 A B C D 4 Pzas. 4 Pzas. 1 Pza. 1 Pza.
58.377/58.402 2.298/2.299	63.246/63.287 2.490/2.492	25.63 1.009	2.426 0.0955	0.0152/0.0914 0.0006/0.0036	95 N.m 70 Lbs.Ft Cabezas de Flujo Cruzado	
47.452/47.478 1.868/1.869	50.775/50.825 1.999/2.001	21.97 0.865	1.636 0.0644	0.0127/0.1270 0.0005/0.0050		3 Piezas





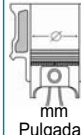
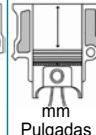





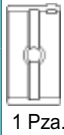

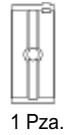
GM CHEVROLET

MORESA!

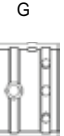
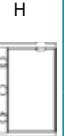
GM CHEVROLET BUICK OLDSMOBILE PONTIAC



CIL.	AÑO	MOTOR / APLICACIÓN		Diámetro del Cilindro Nominal Bore	Carrera Stroke	COJINETE, BUJE O ARANDELA	No. de Parte	Ubicación Location
CYL.	YEAR	ENGINE / APPLICATION		 mm Pulgadas	 mm Pulgadas	BEARING, BUSHING OR THURST WASHER	Part Number	
V6	1980-85	173 (2.8L) Chevrolet OHV, First Design a Small Journal Size 63.3mm (2800 cc) Camaro, Celebrity, Century, Citation, Firebird, Omega, Phoenix, Riviera, S10, S15, Skylark	88.98 3.503	76.00 2.992	COJINETE DE BIELA	6B1238 STD 010 020 030 040	TODOS	
	1985-93	173 (2.8L) Chevrolet OHV, Second Design a Large Journal Size 67.2mm 67.2mm (2800 cc) Beretta, Camaro, Cavalier, Celebrity, Century, Corsica, Cutlass, Cutlass Ciera, Fiero, Firebird, Firenza, Grand Prix, Regal, S10, S15, Sonoma	88.98 3.503	76.00 2.992	COJINETE DE BANCADA 1980-85	4C1494 STD 010 020 030 040	1 (A, B)	
							2 (C, D)	
							3 (E, F)	
							4 (G, H)	
	1985-93	173 (2.8L) Chevrolet OHV, Second Design a Large Journal Size 67.2mm 67.2mm (2800 cc) Beretta, Camaro, Cavalier, Celebrity, Century, Corsica, Cutlass, Cutlass Ciera, Fiero, Firebird, Firenza, Grand Prix, Regal, S10, S15, Sonoma	88.98 3.503	76.00 2.992	COJINETE DE BANCADA 1985-93	4C2037 STD 010 020 030 040	1-4 (A, B)	
							2 (C, D)	
							3 (E, F)	
	1985-93	173 (2.8L) Chevrolet OHV, Second Design a Large Journal Size 67.2mm 67.2mm (2800 cc) Beretta, Camaro, Cavalier, Celebrity, Century, Corsica, Cutlass, Cutlass Ciera, Fiero, Firebird, Firenza, Grand Prix, Regal, S10, S15, Sonoma	88.98 3.503	76.00 2.992	BUJE DE ARBOL	MO1492M STD 010	1	
							2-3	
4								

Línea Line
12

Diámetro Estándar del Muñón Standard Shaft Diameter	Diámetro Total del Alojamiento Housing Bore	Ancho del Cojinete Width Bearing	Espesor Máximo de Pared Max Wall Thickness	Claro de Lubricación Oil Clearance	Torque Torque	Imagen del Cojinete / Arandela Image of the Bearing and Thrust Washer
mm Pulgadas	mm Pulgadas	mm Pulgadas	mm Pulgadas	mm Pulgadas	N.m Lbs.Ft	
50.757/50.782 1.998/1.999	53.962/53.988 2.125/2.126	18.29 0.720	1.580 0.0622	0.0254/0.0812 0.0010/0.0032	53 N.m 39 Lbs.Ft	 12 Piezas
63.340/63.363 2.494/2.495	68.250/68.275 2.687/2.688	24.64 0.970	2.433 0.0958	0.0279/0.1016 0.0011/0.0040	85 a 100 N.m 63 a 74 Lbs.Ft	A  1 Pza. B  1 Pza. C  1 Pza. D  1 Pza.
63.340/63.363 2.494/2.495	68.250/68.275 2.687/2.688	18.85 0.742	2.433 0.0958	0.0279/0.1016 0.0011/0.0040		E  1 Pza. F  1 Pza. G  1 Pza. H  1 Pza.
63.340/63.363 2.494/2.495	68.250/68.275 2.687/2.688	31.70 1.248	2.433 0.0958	0.0279/0.1016 0.0011/0.0040		
63.340/63.363 2.494/2.495	68.250/68.275 2.687/2.688	23.93 0.942	2.433 0.0958	0.0279/0.1016 0.0011/0.0040		
67.239/67.264 2.647/2.648	72.149/72.174 2.841/2.842	24.82 0.977	2.426 0.0955	0.0381/0.0914 0.0015/0.0036	85 a 100 N.m 63 a 74 Lbs.Ft	A  2 Pz. B  2 Pz. C  1 Pza. D  1 Pza. E  1 Pza. F  1 Pza.
67.239/67.264 2.647/2.648	72.149/72.174 2.841/2.842	18.75 0.738	2.426 0.0955	0.0381/0.0914 0.0015/0.0036		
67.239/67.264 2.647/2.648	72.149/72.174 2.841/2.842	23.93 0.942	2.426 0.0955	0.0381/0.0914 0.0015/0.0036		
47.440/47.490 1.868/1.870	51.031/51.054 2.009/2.010	15.88 0.625	1.755 0.0691	0.0381/0.1041 0.0015/0.0041		1 Pieza
47.440/47.490 1.868/1.870	50.770/50.805 1.999/2.000	16.00 0.630	1.626 0.0640	0.0381/0.1041 0.0015/0.0041		2 Pieza
47.440/47.490 1.868/1.870	51.031/51.054 2.009/2.010	15.88 0.625	1.755 0.0691	0.0381/0.1041 0.0015/0.0041		1 Pieza

GM CHEVROLET

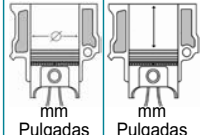
MORESA!

CIL.	AÑO	MOTOR / APLICACIÓN			Diámetro del Cilindro Nominal Bore	Carrera Stroke	COJINETE, BUJE O ARANDELA	No. de Parte	Ubicación Location
CYL.	YEAR	ENGINE / APPLICATION			mm Pulgadas	mm Pulgadas	BEARING, BUSHING OR THURST WASHER	Part Number	
V6	1987-89	173 (2.8L) Chevrolet LPG (2800 cc)	88.98 3.503	76.00 2.992	COJINETE DE BIELA	6B1238 STD 010 020 030 040	TODOS		
	1987-89	173 (2.8L) Chevrolet Meth (2800 cc)	88.98 3.503	76.00 2.992					
	1988-05	191 (3.1L) Types D,M,T,W,V6 (3100 cc) 6000, Achieva, Beretta, Camaro, Cavalier, Celebrity, Century, Corsica, Cutlass, Cutlass Ciera, Firebird, Grand Am, Grand Prix, Lumina, Lumina APV, Malibu, Monte Carlo, Silhouette, Skylark, Somerset, Sunbird, Tempest, Transport	89.03 3.505	84.00 3.307	COJINETE DE BANCADA	4C2037 STD 010 020 030 040	1-4 (A, B)		
							2 (C, D)		
							3 (E, F)		
	1989-90	191 (3.1L) Chevrolet Turbo OHV (3100 cc) Grand Prix	89.03 3.505	84.00 3.307	BUJE DE ARBOL	MO1492M STD 010	1		
	1993-03	207 (3.4L) OHV Type S (3400 cc) Alero, Aztec, Camaro, Firebird, Grand Am, Impala, Lumina APV, Montana, Rendezvous, Silhouette, Transport	92.02 3.623	84.07 3.310			2-3		
							4		
	1991-97	207 (3.4L) DOHC 24 valve Type X (3400 cc) Cutlass, Grand Prix, Lumina, Monte Carlo	92.02 3.623	84.07 3.310	BUJE DE ARBOL 1989-93 1985-89 motores con 20 tornillos en el carter	MO1755M STD	1-4		
							2-3		

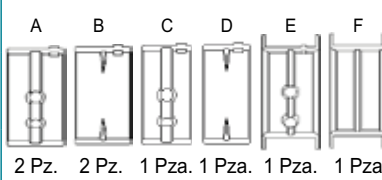

Línea Line
13

Diámetro Estándar del Muñón Standard Shaft Diameter	Diámetro Total del Alojamiento Housing Bore	Ancho del Cojinete Width Bearing	Espesor Máximo de Pared Max Wall Thickness	Claro de Lubricación Oil Clearance	Torque Torque	Imagen del Cojinete / Arandela Image of the Bearing and Thrust Washer
mm Pulgadas	mm Pulgadas	mm Pulgadas	mm Pulgadas	mm Pulgadas	N.m Lbs.Ft	
50.757/50.782 1.998/1.999	53.962/53.988 2.125/2.126	18.29 0.720	1.580 0.0622	0.0254/0.0812 0.0010/0.0032	53 N.m 39 Lbs.Ft	 12 Piezas
67.239/67.264 2.647/2.648	72.149/72.174 2.841/2.842	24.82 0.977	2.426 0.0955	0.0381/0.0914 0.0015/0.0036	85 a 100 N.m 63 a 74 Lbs.Ft	 2 Pz. 2 Pz. 1 Pza. 1 Pza. 1 Pza. 1 Pza.
67.239/67.264 2.647/2.648	72.149/72.174 2.841/2.842	18.75 0.738	2.426 0.0955	0.0381/0.0914 0.0015/0.0036		
67.239/67.264 2.647/2.648	72.149/72.174 2.841/2.842	23.93 0.942	2.426 0.0955	0.0381/0.0914 0.0015/0.0036		
47.440/47.490 1.868/1.870	51.031/51.054 2.009/2.010	15.88 0.625	1.755 0.0691	0.0381/0.1041 0.0015/0.0041		1 Pieza
47.440/47.490 1.868/1.870	50.770/50.805 1.999/2.000	16.00 0.630	1.626 0.0640	0.0381/0.1041 0.0015/0.0041		2 Pieza
47.440/47.490 1.868/1.870	51.031/51.054 2.009/2.010	15.88 0.625	1.755 0.0691	0.0381/0.1041 0.0015/0.0041		1 Pieza
45.339/45.364 1.785/1.786	49.162/49.213 1.936/1.938	19.30 0.760	1.887 0.0743	0.0127/0.1397 0.0005/0.0055		2 Piezas
45.339/45.364 1.785/1.786	48.654/48.705 1.916/1.918	15.88 0.625	1.631 0.0642	0.0127/0.1397 0.0005/0.0055		2 Piezas

GM CHEVROLET

MORESA!

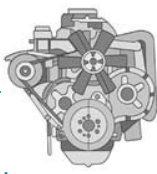
GM CHEVROLET BUICK OLDSMOBILE PONTIAC

CIL.	AÑO	MOTOR / APLICACIÓN		Diámetro del Cilindro Nominal Bore	Carrera Stroke	COJINETE, BUJE O ARANDELA	No. de Parte	Ubicación Location	
CYL.	YEAR	ENGINE / APPLICATION		mm Pulgadas	mm Pulgadas	BEARING, BUSHING OR THURST WASHER	Part Number		
14	V6	1982-88	181 (3.0L) Buick OHV (3000 cc) Calais, Century, Cutlass Ciera, Delta 88, Grand Am, LeSabre, Skylark, Somerset	96.52 3.800	67.56 2.660	COJINETE DE BIELA	6B1228 STD 010 020 030 040	TODOS	
		1978-89	231 (3.8L) Buick Turbo OHV (3800 cc) Century, Firebird, LeSabre, Monte Carlo, Regal, Riviera	96.52 3.800	86.36 3.400	COJINETE DE BANCADA	4C960 STD 010 020 030	1-3 (A, B)	
								4 (A, C)	
								2 (D, E)	
					96.52 3.800	86.36 3.400	BUJE DE ARBOL 1975-85 motores con 14 tornillos en el carter	MO1462M STD	1
									2-3-4
							BUJE DE ARBOL 1985-89 motores con 20 tornillos en el carter	MO1755M STD	1-4
							2-3		
					BUJE DE ARBOL 1975-85 motores con 14 tornillos en el carter	MO1782M STD	1		
							2-3-4		
15	L6	1962-67	194 (3.2L) Chevrolet OHV (3184 cc) Chevelle, Chevy II, G10, G1000, P10	90.47 3.562	82.55 3.250	COJINETE DE BIELA	6B745 STD 010 020 030 040 050 060	TODOS	
		1964-65	215 (3.5L) Pontiac OHV (3529 cc) Tempest	95.25 3.750	82.55 3.250				
		1962-70	230 (3.8L) Chevrolet OHV (3769 cc) Bel Air, Biscayne, C10, C20, C30, C50, Camaro, Chevelle, Chevy II, G10, G20, G1000, G1500, Impala, K10, K20, L50, P10, P20, P30, P50, P1000, P1500, P2500, P3500, T50	98.43 3.875	82.55 3.250	COJINETE DE BANCADA	7C617 STD 010 020 030 040	1-2-3-4-5-6 (A, B)	
								7 (C, D)	
1966-67	230 (3.8L) Pontiac SOHC 12 valve (3769 cc) Firebird, Tempest	98.43 3.875	82.55 3.250	BUJE DE ARBOL 1971-90	MO1557M STD 010	1-2-3-4			









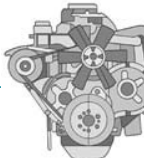

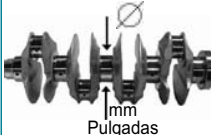



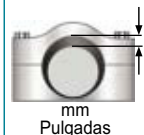

Diámetro Estándar del Muñón Standard Shaft Diameter	Diámetro Total del Alojamiento Housing Bore	Ancho del Cojinete Width Bearing	Espesor Máximo de Pared Max Wall Thickness	Claro de Lubricación Oil Clearance	Torque Torque	Imagen del Cojinete / Arandela Image of the Bearing and Thrust Washer
42.972/42.987 1.692/1.692	45.999/46.012 1.811/1.812	16.64 0.655	1.496 0.0589	0.0127/0.0762 0.0005/0.0030	54 N.m 40 Lbs.Ft	 12 Piezas
63.475/63.500 2.499/2.500	68.250/68.275 2.687/2.688	22.07 0.869	2.375 0.0935	0.0127/0.0863 0.0005/0.0034	149 N.m 110 Lbs.Ft	 A: 3 Pzas. B: 2 Pzas. C: 1 Pza. D: 1 Pza. E: 1 Pza.
63.475/63.500 2.499/2.500	68.250/68.275 2.687/2.688	22.07 0.869	2.375 0.0935	0.0127/0.0863 0.0005/0.0034		
63.475/63.500 2.499/2.500	68.250/68.275 2.687/2.688	26.87 1.058	2.375 0.0935	0.0127/0.0863 0.0005/0.0034		
45.339/45.364 1.785/1.786	48.654/48.705 1.916/1.918	19.30 0.760	1.631 0.0642	0.0127/0.1397 0.0005/0.0055		1 Pieza
45.339/45.364 1.785/1.786	48.654/48.705 1.916/1.918	15.88 0.625	1.631 0.0642	0.0127/0.1397 0.0005/0.0055		3 Piezas
45.339/45.364 1.785/1.786	49.162/49.213 1.936/1.938	19.30 0.760	1.887 0.0743	0.0127/0.1397 0.0005/0.0055		2 Piezas
45.339/45.364 1.785/1.786	48.654/48.705 1.916/1.918	15.88 0.625	1.631 0.0642	0.0127/0.1397 0.0005/0.0055		2 Piezas
45.339/45.364 1.785/1.786	48.654/48.705 1.916/1.918	19.30 0.760	1.631 0.0642	0.0127/0.1397 0.0005/0.0055		1 Pieza
45.339/45.364 1.785/1.786	48.654/48.705 1.916/1.918	15.88 0.625	1.631 0.0642	0.0127/0.1397 0.0005/0.0055		3 Piezas
50.775/50.800 1.999/2.000	53.967/53.980 2.125/2.125	21.39 0.842	1.577 0.0621	0.0254/0.0889 0.0010/0.0035	41 a 47 N.m 30 a 35 Lbs.Ft (194 3.2L) 47 a 61 N.m 35 a 45 Lbs.Ft (215 3.5L, 230 3.8L)	 12 Piezas
58.377/58.402 2.298/2.299	63.261/63.287 2.491/2.492	20.50 0.807	2.426 0.0955	0.0152/0.0914 0.0006/0.0036	81 a 95 N.m	 A: 6 Pzas. B: 6 Pzas. C: 1 Pza. D: 1 Pza.
58.377/58.402 2.298/2.299	63.261/63.287 2.491/2.492	25.63 1.009	2.426 0.0955	0.0152/0.0914 0.0006/0.0036	60 a 70 Lbs.Ft	
47.452/47.478 1.868/1.869	50.775/50.825 1.999/2.001	21.97 0.865	1.636 0.0644	0.0127/0.1270 0.0005/0.0050		4 Piezas

GM CHEVROLET

MORESA!

GM CHEVROLET BUICK OLDSMOBILE PONTIAC



CIL.	AÑO	MOTOR / APLICACIÓN		Diámetro del Cilindro Nominal Bore	Carrera Stroke	COJINETE, BUJE O ARANDELA	No. de Parte	Ubicación Location
CYL.	YEAR	ENGINE / APPLICATION		mm Pulgadas	mm Pulgadas	BEARING, BUSHING OR THURST WASHER	Part Number	→ 1 2 3 4 5
16	V6	1964-77	196 (3.2L) Buick OHV (3200 cc) Century, Regal	88.90 3.500	86.36 3.400	COJINETE DE BIELA	6B610 STD 010 020	TODOS
		1980-84	252 (4.1L) Buick OHV (4100 cc) Bonneville, Century, Commercial Chassis, Deville, Deville, Eldorado, Electra, Fleetwood, Grand Prix, LeSabre, Monza, Ninety Eight, Regal, Riviera, Toronado	100.71 3.965	86.36 3.400	COJINETE DE BANCADA 1978-79	4C960 STD 010 020 030	1-3 (A, B) 4 (A, C) 2 (D, E)
					BUJE DE ARBOL 1975-85	MO1462M STD	1 2-3-4	
					BUJE DE ARBOL 1975-85 1975-85 motores con 14 tornillos en el carter	MO1782M STD	1 2-3-4	
17	V6	1978-79	200 (3.3L) Chevrolet OHV (3300 cc) Caballero, El Camino, Malibu, Monte Carlo	88.95 3.502	88.39 3.480	COJINETE DE BIELA	6B1227 STD 010 020 030	TODOS
		1980-84	229 (3.8L) Chevrolet OHV (K) (3800 cc) Caballera, Camaro, Caprice, El Camino, Impala, Laurentain, Lemans, Malibu, Monte Carlo	94.89 3.736	88.49 3.484	COJINETE DE BANCADA	4C1454 STD 010 020 030 040	1-2-3 (A, B) 4 (C, D)
					BUJE DE ARBOL	MO1463M STD	1 2-4	
							3	

Diámetro Estándar del Muñón Standard Shaft Diameter	Diámetro Total del Alojamiento Housing Bore	Ancho del Cojinete Width Bearing	Espesor Máximo de Pared Max Wall Thickness	Claro de Lubricación Oil Clearance	Torque Torque	Imagen del Cojinete / Arandela Image of the Bearing and Thrust Washer
						
mm Pulgadas	mm Pulgadas	mm Pulgadas	mm Pulgadas	mm Pulgadas	N.m Lbs.Ft	
50.787/50.813 2.000/2.001	53.967/53.980 2.125/2.125	18.85 0.742	1.575 0.0620	0.0178/0.0812 0.0007/0.0032	41 a 54 N.m 30 a 40 Lbs.Ft	 12 Piezas
63.475/63.500 2.499/2.500	68.250/68.275 2.687/2.688	22.07 0.869	2.375 0.0935	0.012770.0863 0.0005/0.0034	149 N.m 110 Lbs.Ft	 A
63.475/63.500 2.499/2.500	68.250/68.275 2.687/2.688	22.07 0.869	2.375 0.0935	0.012770.0863 0.0005/0.0034		 B
63.475/63.500 2.499/2.500	68.250/68.275 2.687/2.688	26.87 1.058	2.375 0.0935	0.012770.0863 0.0005/0.0034		 C
63.475/63.500 2.499/2.500	68.250/68.275 2.687/2.688	26.87 1.058	2.375 0.0935	0.012770.0863 0.0005/0.0034		 D
63.475/63.500 2.499/2.500	68.250/68.275 2.687/2.688	26.87 1.058	2.375 0.0935	0.012770.0863 0.0005/0.0034		 E
45.339/45.364 1.785/1.786	48.654/48.705 1.916/1.918	19.30 0.760	1.631 0.0642	0.0127/0.1397 0.0005/0.0055		1 Pieza
45.339/45.364 1.785/1.786	48.654/48.705 1.916/1.918	15.88 0.625	1.631 0.0642	0.0127/0.1397 0.0005/0.0055		3 Piezas
45.339/45.364 1.785/1.786	48.654/48.705 1.916/1.918	19.30 0.760	1.631 0.0642	0.0127/0.1397 0.0005/0.0055		1 Pieza
45.339/45.364 1.785/1.786	48.654/48.705 1.916/1.918	15.88 0.625	1.631 0.0642	0.0127/0.1397 0.0005/0.0055		3 Piezas
53.315/53.340 2.099/2.100	56.507/56.533 2.225/2.226	18.11 0.713	1.575 0.0620	0.0076/0.0838 0.0003/0.0033	61 N.m 45 Lbs.Ft	 12 Piezas
62.189/62.212 2.448/2.449	67.071/67.094 2.641/2.642	20.50 0.807	2.426 0.0955	0.0152/0.0914 0.0006/0.0036	95 N.m 70 Lbs.Ft	 A
62.177/62.200 2.448/2.449	67.071/67.094 2.641/2.642	43.64 1.718	2.426 0.0955	0.0279/0.1041 0.0011/0.0041		 B
47.452/47.478 1.868/1.869	51.283/51.333 2.019/2.021	18.80 0.740	1.890 0.0744	0.0254/0.1270 0.0010/0.0050		1 Pieza
47.452/47.478 1.868/1.869	51.029/51.079 2.009/2.011	18.92 0.745	1.763 0.0694	0.0254/0.1270 0.0010/0.0050		2 Pieza
47.452/47.478 1.868/1.869	50.775/50.825 1.999/2.001	18.80 0.740	1.636 0.0644	0.0254/0.1270 0.0010/0.0050		1 Pieza

GM CHEVROLET



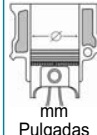
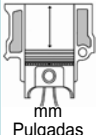



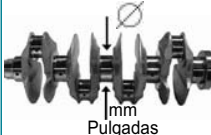

MORESA!

GM CHEVROLET BUICK OLDSMOBILE PONTIAC

CIL.	AÑO	MOTOR / APLICACIÓN		Diámetro del Cilindro Nominal Bore	Carrera Stroke	COJINETE, BUJE O ARANDELA	No. de Parte	Ubicación Location
CYL.	YEAR	ENGINE / APPLICATION		 mm Pulgadas	 mm Pulgadas	BEARING, BUSHING OR THURST WASHER	Part Number	
V6	1988-93	204 (3.3L) Buick OHV (3300 cc) Achieva, Century, Cutlass Ciera, Grand Am, Skylark, Somerset		93.98 3.700	80.26 3.160	COJINETE DE BIELA 1988-90	6B1228 STD 010 020 030 040	TODOS
						COJINETE DE BIELA 1990-93	6B1443 STD 010 020 030	TODOS
						COJINETE DE BANCADA 1989-90	4C960 STD 010 020 030	1-3 (A, B)
								4 (A, C)
								2 (D, E)
						COJINETE DE BANCADA 1991-93	4C1822 STD 010 020 030	1-3 (A, B)
								4 (C, D)
								2 (E, F)
						BUJE DE ARBOL	MO1755M STD	1-4
								2-3

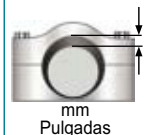
Línea Line

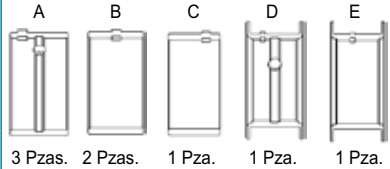
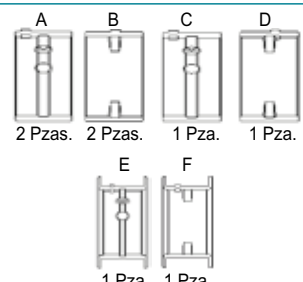

18







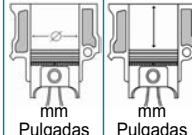
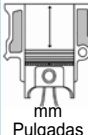

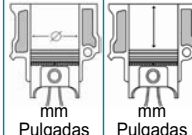
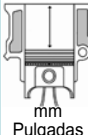
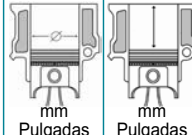
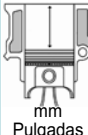
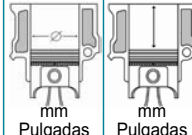
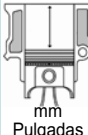



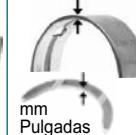
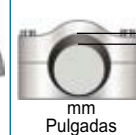







Diámetro Estándar del Muñón Standard Shaft Diameter	Diámetro Total del Alojamiento Housing Bore	Ancho del Cojinete Width Bearing	Espesor Máximo de Pared Max Wall Thickness	Claro de Lubricación Oil Clearance	Torque Torque	Imagen del Cojinete / Arandela Image of the Bearing and Thrust Washer
						
42.972/42.987 1.692/1.692	45.999/46.012 1.811/1.812	16.64 0.655	1.496 0.0589	0.0127/0.0762 0.0005/0.0030	54 N.m 40 Lbs.Ft	 12 Piezas
57.117/57.137 2.249/2.250	60.295/60.312 2.374/2.375	18.31 0.721	1.570 0.0618	0.0254/0.0889 0.0010/0.0035	27 N.m + 50° 20 Lbs.Ft + 50°	 12 Piezas
63.475/63.500 2.499/2.500	68.250/68.275 2.687/2.688	22.07 0.869	2.375 0.0935	0.0127/0.0863 0.0005/0.0034	35 N.m + 50°	 3 Pzas. 2 Pzas. 1 Pza. 1 Pza. 1 Pza.
63.475/63.500 2.499/2.500	68.250/68.275 2.687/2.688	22.07 0.869	2.375 0.0935	0.0127/0.0863 0.0005/0.0034	26 Lbs.Ft + 50°	
63.475/63.500 2.499/2.500	68.250/68.275 2.687/2.688	26.87 1.058	2.375 0.0935	0.0127/0.0863 0.0005/0.0034		
63.470/63.495 2.499/2.500	68.250/68.275 2.687/2.688	22.07 0.869	2.377 0.0936	0.0127/0.0812 0.0005/0.0032	35 N.m + 50°	 2 Pzas. 2 Pzas. 1 Pza. 1 Pza. 1 Pza. 1 Pza.
63.470/63.495 2.499/2.500	68.250/68.275 2.687/2.688	22.07 0.869	2.377 0.0936	0.0127/0.0812 0.0005/0.0032	26 Lbs.Ft + 50°	
63.470/63.495 2.499/2.500	68.250/68.275 2.687/2.688	26.87 1.058	2.377 0.0936	0.0127/0.0812 0.0005/0.0032		
45.339/45.364 1.785/1.786	49.162/49.213 1.936/1.938	19.30 0.760	1.887 0.0743	0.0127/0.1397 0.0005/0.0055		2 Piezas
45.339/45.364 1.785/1.786	48.654/48.705 1.916/1.918	15.88 0.625	1.631 0.0640	0.0127/0.1397 0.0005/0.0055		2 Piezas

GM CHEVROLET

MORESA

GM CHEVROLET BUICK OLDSMOBILE PONTIAC

CIL.	AÑO	MOTOR / APLICACIÓN		Diámetro del Cilindro Nominal Bore	Carrera Stroke	COJINETE, BUJE O ARANDELA	No. de Parte	Ubicación Location		
CYL.	YEAR	ENGINE / APPLICATION		 mm Pulgadas	 mm Pulgadas	BEARING, BUSHING OR THURST WASHER	Part Number			
19	V6	1993-03 207 (3.4L) OHV Type S (3400 cc) Alero, Aztec, Camaro, Firebird, Grand Am, Impala, Lumina APV, Montana, Rendezvous, Silhouette, Transport	 mm Pulgadas	 mm Pulgadas	COJINETE DE BIELA	6B1238 STD 010 020 030 040	TODOS			
								1991-97 207 (3.4L) DOHC 24 valve Type X (3400 cc) Cutlass, Grand Prix, Lumina, Monte Carlo	COJINETE DE BANCADA	4C2037 STD 010 020 030 040
	2 (C, D)									
	BUJE DE ARBOL	MO1828M STD	1							
2-3	4									
20	V6	1964-77 225 (3.7L) Buick OHV (3692 cc) F85, Skylark, Special	 mm Pulgadas	 mm Pulgadas	COJINETE DE BIELA	6B610 STD 010 020	TODOS			
								COJINETE DE BANCADA	4C960 STD 010 020 030	1-3 (A, B)
										4 (A, C)
2 (D, E)										
21	V6	1988-95 231 (3.8L) Buick OHV, Vin "C", "L", Series I (3800 cc) Bonneville, Century, Electra, Firebird, Grand Prix, LeSabre, Lumina, Lumina APV, Ninety Eight, Park Avenue, Reatta, Regal, Toronado, Transport	 mm Pulgadas	 mm Pulgadas	COJINETE DE BIELA 1991-05	6B1443 STD 010 020 030	TODOS			
					COJINETE DE BIELA 1978-90	6B1228 STD 010 020 030 040	TODOS			
					COJINETE DE BIELA 1975-77	6B610 STD 010 020	TODOS			

Diámetro Estándar del Muñón Standard Shaft Diameter	Diámetro Total del Alojamiento Housing Bore	Ancho del Cojinete Width Bearing	Espesor Máximo de Pared Max Wall Thickness	Claro de Lubricación Oil Clearance	Torque Torque	Imagen del Cojinete / Arandela Image of the Bearing and Thrust Washer
						
mm Pulgadas	mm Pulgadas	mm Pulgadas	mm Pulgadas	mm Pulgadas	N.m Lbs.Ft	
50.757/50.782 1.998/1.999	53.962/53.988 2.125/2.126	18.29 0.720	1.580 0.0622	0.0254/0.0812 0.0010/0.0032	53 N.m 39 Lbs.Ft	 12 Piezas
67.239/67.264 2.647/2.648	72.149/72.174 2.841/2.842	24.82 0.977	2.426 0.0955	0.0381/0.0914 0.0015/0.0036	85 a 100 N.m	A  B  C  D  E  F 
67.239/67.264 2.647/2.648	72.149/72.174 2.841/2.842	18.75 0.738	2.426 0.0955	0.0381/0.0914 0.0015/0.0036	63 a 74 Lbs.Ft	2 Pz. 2 Pz. 1 Pza. 1 Pza. 1 Pza. 1 Pza.
67.239/67.264 2.647/2.648	72.149/72.174 2.841/2.842	23.93 0.942	2.426 0.0955	0.0381/0.0914 0.0015/0.0036		1 Pieza
47.447/47.498 1.868/1.870	51.029/51.079 2.009/2.011	30.00 1.181	1.752 0.0690	0.0381/0.0889 0.0015/0.0035		1 Pieza
47.447/47.498 1.868/1.870	50.775/50.825 1.999/2.001	17.62 0.694	1.625 0.0640	0.0381/0.1041 0.0015/0.0041		2 Pieza
47.447/47.498 1.868/1.870	51.029/51.079 2.009/2.011	16.10 0.634	1.752 0.0690	0.0381/0.1041 0.0015/0.0041		1 Pieza
50.787/50.813 2.000/2.001	53.967/53.980 2.125/2.125	18.85 0.742	1.575 0.0620	0.0177/0.0812 0.0007/0.0032	41 a 54 N.m 30 a 40 Lbs.Ft	 12 Piezas
63.475/63.500 2.499/2.500	68.250/68.275 2.687/2.688	22.07 0.869	2.375 0.0935	0.0127/0.0863 0.0005/0.0034	149 N.m 110 Lbs.Ft	A  B  C  D  E 
63.475/63.500 2.499/2.500	68.250/68.275 2.687/2.688	22.07 0.869	2.375 0.0935	0.0127/0.0863 0.0005/0.0034		3 Pzas. 2 Pzas. 1 Pza. 1 Pza. 1 Pza.
63.475/63.500 2.499/2.500	68.250/68.275 2.687/2.688	26.87 1.058	2.375 0.0935	0.0127/0.0863 0.0005/0.0034		
57.117/57.137 2.249/2.250	60.295/60.312 2.374/2.375	18.31 0.721	1.570 0.0618	0.0254/0.0889 0.0010/0.0035	27 N.m + 50° 20 Lbs.Ft + 50°	 12 Piezas
42.972/42.987 1.692/1.692	45.999/46.012 1.811/1.812	16.64 0.655	1.496 0.0589	0.0127/0.0762 0.0005/0.0030	54 N.m 40 Lbs.Ft	 12 Piezas
50.787/50.813 2.000/2.001	53.967/53.980 2.125/2.125	18.85 0.742	1.575 0.0620	0.0177/0.0812 0.0007/0.0032	40 a 54 N.m 30 a 40 Lbs.Ft	 12 Piezas

GM CHEVROLET

MORESA

GM CHEVROLET BUICK OLDSMOBILE PONTIAC

CIL.	AÑO	MOTOR / APLICACIÓN	Diámetro del Cilindro Nominal Bore	Carrera Stroke	COJINETE, BUJE O ARANDELA	No. de Parte	Ubicación Location
CYL.	YEAR	ENGINE / APPLICATION	mm Pulgadas	mm Pulgadas	BEARING, BUSHING OR THURST WASHER	Part Number	→ 1 2 3 4 5
V6	1995-04	231 (3.8L) Buick OHV, Vin "K", Series II (3800 cc) Bonneville, Camaro, Firebird, Grand Prix, Impala, LeSabre, Lumina, Lumina APV, Monte Carlo, Park Avenue, Regal, Regency, Riviera, Silhouette, Toronado, Transport	96.52 3.800	86.36 3.400	COJINETE DE BANCADA 1975-90	4C960 STD 010 020 030	1-3 (A, B) 4 (A, C) 2 (D, E)
	1991-04	231 (3.8L) Buick Supercharged OHV, Vin "1" (3800 cc) Bonneville, Grand Prix, Impala, Monte Carlo, Ninety Eight, Park Avenue, Regal, Riviera	96.52 3.800	86.36 3.400	COJINETE DE BANCADA 1991-93	4C1822 STD 010 020 030	1-3 (A, B) 4 (C, D)
	1975-88	231 (3.8L) Buick OHV, Exc. 3800 Series I and II (3800 cc) Apollo, Caballera, Camaro, Caprice, Catalina, Cutlass, Delta 88, El Camino, Electra, Firebird, Grand Am, Grand Prix, Malibu, Monte Carlo, Monza, Nova, Omega, Parisienne, Phoenix, Regal, Riviera, Skyhawk, Skylark, Startire, Ventura	96.52 3.800	86.36 3.400	COJINETE DE BANCADA 1995-05	4C2022 STD 010 020 030	1 (A, B) 2 (C, D) 3 (E, F) 4 (G, H)
	1988-95	231 (3.8L) Buick OHV, Vin "C", "L", Series I (3800 cc) Bonneville, Century, Electra, Firebird, Grand Prix, LeSabre, Lumina, Lumina APV, Ninety Eight, Park Avenue, Reatta, Regal, Toronado, Transport	96.52 3.800	86.36 3.400	BUJE DE ARBOL 1984-85 VIN 3 motores con 14 tornillos en el carter	MO1462M STD	1 2-3-4
	1995-05	231 (3.8L) Buick OHV Type K 3800 Series II (3800 cc) Bonneville, Camaro, Firebird, Grand Prix, Impala, LeSabre, Lumina, Lumina APV, Monte Carlo, Park Avenue, Regal, Regency, Riviera, Silhouette, Toronado, Transport	96.52 3.800	86.36 3.400	BUJE DE ARBOL 1986-94 VIN 3 motores con 20 tornillos en el carter	MO1755M STD	1-4 2-3
	1991-05	231 (3.8L) Buick Supercharged OHV, Vin "1" (3800 cc) Bonneville, Grand Prix, Impala, Monte Carlo, Ninety Eight, Park Avenue, Regal, Riviera	96.49 3.799	86.36 3.400	BUJE DE ARBOL 1984-85 VIN 3 motor con 14 tornillos en el carter Buje de posición 1 con ranura de aceite a sus 360°	MO1782M STD	1 2-3-4
	1996-99	231 (3.8L) Type 1 Supercharged 3800 Series II (3800 cc) Bonneville, Camaro, Firebird, Grand Prix, Impala, LeSabre, Lumina, Lumina APV, Monte Carlo, Park Avenue, Regal, Regency, Riviera, Silhouette, Toronado, Transport	96.49 3.799	86.36 3.400	BUJE DE ARBOL 1995-05 Vin "K"	MO1889M STD	1 2-3-4
					BUJE DE FLECHA BALANCEADORA	MO3204DR STD	1

Línea Line



21

Diámetro Estándar del Muñón Standard Shaft Diameter	Diámetro Total del Alojamiento Housing Bore	Ancho del Cojinete Width Bearing	Espesor Máximo de Pared Max Wall Thickness	Claro de Lubricación Oil Clearance	Torque Torque	Imagen del Cojinete / Arandela Image of the Bearing and Thrust Washer
63.475/63.500 2.499/2.500	68.250/68.275 2.687/2.688	22.07 0.869	2.375 0.0935	0.0127/0.0863 0.0005/0.0034	149 N.m 110 Lbs.Ft	 3 Pzas. 2 Pzas. 1 Pza. 1 Pza. 1 Pza.
63.475/63.500 2.499/2.500	68.250/68.275 2.687/2.688	22.07 0.869	2.375 0.0935	0.0127/0.0863 0.0005/0.0034		
63.475/63.500 2.499/2.500	68.250/68.275 2.687/2.688	26.87 1.058	2.375 0.0935	0.0127/0.0863 0.0005/0.0034		
63.470/63.495 2.499/2.500	68.250/68.275 2.687/2.688	22.07 0.869	2.377 0.0936	0.0127/0.0812 0.0005/0.0032	35 N.m + 50° 26 Lbs.Ft + 50°	 2 Pzas. 2 Pzas. 1 Pza. 1 Pza. 1 Pza. 1 Pza.
63.470/63.495 2.499/2.500	68.250/68.275 2.687/2.688	22.07 0.869	2.377 0.0936	0.0127/0.0812 0.0005/0.0032		
63.470/63.495 2.499/2.500	68.250/68.275 2.687/2.688	26.87 1.058	2.377 0.0936	0.0127/0.0812 0.0005/0.0032		
68.250/68.275 2.687/2.688	63.195/63.475 2.488/2.499	2.21 0.087	2.380 0.0937	0.0127/0.0558 0.0005/0.0022	35 N.m + 50° 26 Lbs.Ft + 50°	 1 Pza. 1 Pza. 1 Pza. 1 Pza. 1 Pza. 1 Pza. 1 Pza. 1 Pza.
68.250/68.275 2.687/2.688	63.195/63.475 2.488/2.499	26.87 1.058	2.367 0.0932	0.0127/0.0812 0.0005/0.0032		
68.250/68.275 2.687/2.688	63.195/63.475 2.488/2.499	2.21 0.087	2.367 0.0932	0.0127/0.0812 0.0005/0.0032		
68.250/68.275 2.687/2.688	62.992/63.475 2.480/2.449	2.21 0.087	2.380 0.0937	0.0127/0.0558 0.0005/0.0022		1 Pza.
45.339/45.364 1.785/1.786	48.654/48.705 1.916/1.918	19.30 0.760	1.631 0.0642	0.0127/0.1397 0.0005/0.0055		1 Pieza
45.339/45.364 1.785/1.786	48.654/48.705 1.916/1.918	15.88 0.625	1.631 0.0642	0.0127/0.1397 0.0005/0.0055		3 Piezas
45.339/45.364 1.785/1.786	49.162/49.213 1.936/1.938	19.30 0.760	1.887 0.0743	0.0127/0.1397 0.0005/0.0055		2 Piezas
45.339/45.364 1.785/1.786	48.654/48.705 1.916/1.918	15.88 0.625	1.631 0.0642	0.0127/0.1397 0.0005/0.0055		2 Piezas
45.339/45.364 1.785/1.786	48.654/48.705 1.916/1.918	19.30 0.760	1.631 0.0642	0.0127/0.1397 0.0005/0.0055		1 Pieza
45.339/45.364 1.785/1.786	48.654/48.705 1.916/1.918	15.88 0.625	1.631 0.0642	0.0127/0.1397 0.0005/0.0055		3 Piezas
45.339/45.364 1.785/1.786	48.654/48.705 1.916/1.918	19.30 0.760	1.631 0.0642	0.0127/0.1397 0.0005/0.0055		2 Piezas
45.339/45.364 1.785/1.786	48.654/48.705 1.916/1.918	15.88 0.625	1.631 0.0642	0.0127/0.1397 0.0005/0.0055		2 Piezas
30.064/38.100 1.499/1.500	46.673/47.612 1.838/1.875	21.34 0.840	4.739 0.1866	0.0127/0.1295 0.0005/0.0051		1 Pieza

GM CHEVROLET

MORESA

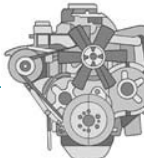
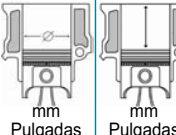
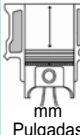









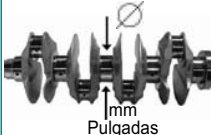

GM CHEVROLET BUICK OLDSMOBILE PONTIAC

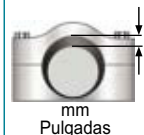
CIL.	AÑO	MOTOR / APLICACIÓN		Diámetro del Cilindro Nominal Bore	Carrera Stroke	COJINETE, BUJE O ARANDELA	No. de Parte	Ubicación Location
CYL.	YEAR	ENGINE / APPLICATION		 mm Pulgadas	 mm Pulgadas	BEARING, BUSHING OR THURST WASHER	Part Number	
L6	1953-62	235 (3.8L) Chevrolet OHV (3861 cc) 4, 6, 3100, 3200, 3600, 3800, Beauville, Bel Air, Brookwood, C10, C20, C30, C40, C50, Del Ray, Deluxe, El Camino, HU, Impala, K, K10, K20, KU, L50, M, Nomad, P10, P20, P30, Special 150, Suburban, T, TP, TR, TS, TV, TW, TX, TY, Townsman, U, UP, UR, US, UV, UW, UX, UY, V, VP, VR, VS, VV, VW, VX, VY, VZ, W, X, Y, Yeoman, Z	90.50 3.563	100.03 3.938	COJINETE DE BIELA	6B416 STD 010 020 030 040	TODOS	
	1954-62	261 (4.2L) Chevrolet OHV (4275 cc) 6, C10, C20, C30, C60, K10, K20, L60, Suburban, T60, V, W, X, Y, Z	95.25 3.750	100.03 3.938	BUJE DE ARBOL	MO1170M STD	1	
							2	
							3	
4								
L6	1968-69	250 (4.1L) Pontiac SOHC 12 valve (4095 cc) Firebird, Tempest	98.43 3.875	89.69 3.531	COJINETE DE BIELA 1994-98	6B1238 STD 010 020 030 040	TODOS	
	1966-84	250 (4.1L) Chevrolet OHV (4100 cc) Apollo, Bel Air, Biscayne, Blazer, C10, C20, C30, C1500, C2500, Camaro, Caprice, Chevelle, Chevy II, Cutlass, El Camino, Firebird, G10, G20, G30, G2500, G3500, Impala, Jimmy, K10, K20, K1500, K2500, Laurentain, Lemans, Nova, Omega, P10, P20, P30, P1500, P2500, P3500, PS40, PS50, SS40, SS50, Skylark, Special, Sprint, TS40, TS50, Ventura	98.43 3.875	89.69 3.531	COJINETE DE BIELA 1966-84	6B745 STD 010 020 030 040 050 060	TODOS	
					COJINETE DE BANCADA	7C617 STD 010 020 030 040	1-2-3-4-5-6 (A, B)	
							7 (C, D)	
	1994-98	250 (4.1L) Chevrolet OHV (4100 cc) Camioneta TBI	98.43 3.875	89.69 3.531	BUJE DE ARBOL 1971-98	MO1557M STD 010	1-2-3-4	

Línea Line

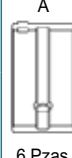
22



23

Diámetro Estándar del Muñón Standard Shaft Diameter	Diámetro Total del Alojamiento Housing Bore	Ancho del Cojinete Width Bearing	Espesor Máximo de Pared Max Wall Thickness	Claro de Lubricación Oil Clearance	Torque Torque	Imagen del Cojinete / Arandela Image of the Bearing and Thrust Washer
						
mm Pulgadas	mm Pulgadas	mm Pulgadas	mm Pulgadas	mm Pulgadas	N.m Lbs.Ft	
58.699/58.725 2.311/2.312	61.892/61.905 2.437/2.437	26.24 1.033	1.575 0.0620	0.0279/0.0914 0.0011/0.0036	54 a 61 N.m 40 a 45 Lbs.Ft	 12 Piezas
54.704/54.729 2.154/2.155	58.014/58.064 2.284/2.286	28.58 1.125	1.628 0.0641	0.0127/0.1270 0.0005/0.0050		1 Pieza
53.116/53.142 2.091/2.092	56.426/56.477 2.222/2.224	23.80 0.937	1.628 0.0641	0.0127/0.1270 0.0005/0.0050		1 Pieza
51.529/51.554 2.029/2.030	54.839/54.889 2.159/2.161	23.80 0.937	1.628 0.0641	0.0127/0.1270 0.0005/0.0050		1 Pieza
49.941/49.967 1.966/1.967	53.251/53.302 2.097/2.099	23.80 0.937	1.631 0.0642	0.0127/0.1270 0.0005/0.0050		1 Pieza
50.757/50.782 1.998/1.999	53.962/53.988 2.125/2.126	18.29 0.720	1.580 0.0622	0.0254/0.0812 0.0010/0.0032	53 N.m 39 Lbs.Ft	 12 Piezas
50.775/50.800 1.999/2.000	53.967/53.980 2.125/2.125	21.39 0.842	1.577 0.0621	0.0254/0.0889 0.0010/0.0035	41 a 47 N.m 30 a 35 Lbs.Ft (194 3.2L) 47 a 61 N.m 35 a 45 Lbs.Ft (215 3.5L, 230 3.8L)	 12 Piezas
58.377/58.402 2.298/2.299	63.261/63.287 2.491/2.492	20.50 0.807	2.426 0.0955	0.0152/0.0914 0.0006/0.0036	81 a 95 N.m	 6 Pzas.
58.377/58.402 2.298/2.299	63.261/63.287 2.491/2.492	25.63 1.009	2.426 0.0955	0.0152/0.0914 0.0006/0.0036	60 a 70 Lbs.Ft	 6 Pzas.
						 1 Pza.
						 1 Pza.
47.452/47.478 1.868/1.869	50.775/50.825 1.999/2.001	21.97 0.865	1.636 0.064	0.0127/0.1270 0.0005/0.0050		4 Piezas

GM CHEVROLET

MORESA!

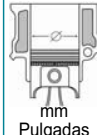
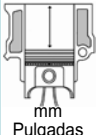



GM CHEVROLET BUICK OLDSMOBILE PONTIAC

CIL.	AÑO	MOTOR / APLICACIÓN		Diámetro del Cilindro Nominal Bore	Carrera Stroke	COJINETE, BUJE O ARANDELA	No. de Parte	Ubicación Location					
CYL.	YEAR	ENGINE / APPLICATION		 mm Pulgadas	 mm Pulgadas	BEARING, BUSHING OR THURST WASHER	Part Number						
V8	1982-88	252 (4.1L) Cadillac OHV (4100 cc) Allante, Commercial Chassis, Deville, Eldorado, Fleetwood, Seville		88.01 3.465	84.00 3.307	COJINETE, BUJE O ARANDELA BEARING, BUSHING OR THURST WASHER BUJE DE ARBOL	MO1757M STD 010	1					
	1988-92	273 (4.5L) Cadillac OHV (4500 cc) Allante, Commercial Chassis, Deville, Eldorado, Fleetwood, Seville		2									
				3									
	1991-95	300 (4.9L) Cadillac OHV (4900 cc) Deville, Eldorado, Fleetwood, Seville		4									
V6	1985-06	262 (4.3L) Chevrolet exc. High Output, OHV (4300 cc) Astro, Blazer, Bonneville, Bravado, C10, C20, C30, C1500, C2500, C3500, Caballera, Caprice, El Camino, Envoy, Express, G10, G20, G30, G1500, G2500, G3500, Grand Prix, Impala, Jimmy, K10, K20, K1500, K2500, K3500, Monte Carlo, P30, P3500, Parisienne, R2500, Regal, S10, S15, Safari, Sierra, Silverado, Sonoma, Surburban, R10, R20, R1500, Trailblazer, V10, V20, V1500, V2500	101.60 4.000	88.49 3.484	COJINETE DE BIELA	6B1358 STD 010 020 030 040	TODOS						
							COJINETE DE BANCADA	4C1454 STD 010 020 030 040	1-2-3 (A, B)				
								BUJE DE ARBOL Para todos los motores excepto 1992-04 con la "T" (localizada frente al block).	MO1463M STD	1			
	1990-91	262 (4.3L) Chevrolet High Output OHV Vin "B" LU4 (4300 cc) Astro, Safari	101.60 4.000	88.39 3.480	BUJE DE ARBOL Para todos los motores excepto 1992-04 con la "T" (localizada frente al block).	MO1463M STD	2-4						
							3						
							1991-93	262 (4.3L) Chevrolet Turbo OHV Vin "Z" LB4 (4300 cc) Syclone, Typhoon	101.60 4.000	88.39 3.480	BUJE DE ARBOL Para todos los motores excepto 1992-04 con la "T" (localizada frente al block).	MO1855M STD	1-4
													2
BUJE DE FLECHA BALANCEADORA 1992-2004, Excepto motores con Cojinetes tipo Roller	MO3204DR STD	3											
		1											

Línea Line

24



25

Diámetro Estándar del Muñón Standard Shaft Diameter	Diámetro Total del Alojamiento Housing Bore	Ancho del Cojinete Width Bearing	Esesor Máximo de Pared Max Wall Thickness	Claro de Lubricación Oil Clearance	Torque Torque	Imagen del Cojinete / Arandela Image of the Bearing and Thrust Washer
mm Pulgadas	mm Pulgadas	mm Pulgadas	mm Pulgadas	mm Pulgadas	N.m Lbs.Ft	
51.709/51.730 2.036/2.037	55.067/55.105 2.168/2.170	15.14 0.596	1.656 0.0652	0.0254/0.1143 0.0010/0.0045		1 Pieza
51.199/51.219 2.016/2.017	54.559/54.597 2.148/2.150	15.14 0.596	1.656 0.0652	0.0254/0.1143 0.0010/0.0045		1 Pieza
50.691/50.711 1.996/1.997	54.051/54.089 2.128/2.130	15.14 0.596	1.656 0.0652	0.0279/0.1168 0.0011/0.0046		1 Pieza
50.180/50.201 1.976/1.976	53.543/53.581 2.108/2.110	15.14 0.596	1.656 0.0652	0.0304/0.1193 0.0012/0.0047		1 Pieza
49.680/49.700 1.956/1.957	53.035/53.073 2.088/2.090	18.29 0.720	1.656 0.0652	0.022870.1117 0.0009/0.0044		1 Pieza
57.130/57.145 2.249/2.250	60.317/60.343 2.375/2.376	19.13 0.753	1.575 0.062	0.0127/0.0787 0.0005/0.0031	61 N.m 45 Lbs.Ft	 12 Piezas
62.189/62.212 2.448/2.449	67.071/67.094 2.641/2.642	20.50 0.807	2.426 0.0955	0.0152/0.0914 0.0006/0.0036	95 N.m 70 Lbs.Ft	A  B  C  D  3 Pzas. 3 Pzas. 1 Pza. 1 Pza.
62.177/62.200 2.448/2.449	67.071/67.094 2.641/2.642	43.64 1.718	2.426 0.0955	0.0279/0.1041 0.0011/0.0041		
47.452/47.478 1.868/1.869	51.283/51.333 2.019/2.021	18.80 0.740	1.890 0.0744	0.0254/0.1270 0.0010/0.0050		1 Pieza
47.452/47.478 1.868/1.869	51.029/51.079 2.009/2.011	18.92 0.745	1.763 0.0694	0.0254/0.1270 0.0010/0.0050		2 Pieza
47.452/47.478 1.868/1.869	50.775/50.825 1.999/2.001	18.80 0.740	1.636 0.0644	0.0254/0.1270 0.0010/0.0050		1 Pieza
47.452/47.780 1.868/1.869	51.283/51.333 2.019/2.021	18.80 0.740	1.889 0.0744	0.0254/0.1270 0.0010/0.0050		2 Pieza
47.452/47.780 1.868/1.869	50.775/50.825 1.999/2.001	18.80 0.740	1.635 0.0644	0.0254/0.1270 0.0010/0.0050		1 Pieza
47.452/47.780 1.868/1.869	51.029/51.079 2.009/2.011	18.796 0.740	1.762 0.0694	0.0254/0.1270 0.0010/0.0050		1 Pieza
30.065/38.100 1.499/1.500	46.673/47.612 1.838/1.875	21.35 0.840	4.739 0.1866	0.0127/0.1295 0.0005/0.0051		1 Pieza

GM CHEVROLET

MORESA!

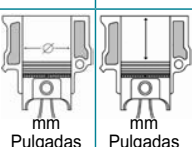
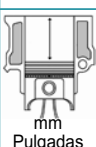

GM CHEVROLET BUICK OLDSMOBILE PONTIAC

CIL.	AÑO	MOTOR / APLICACIÓN		Diámetro del Cilindro Nominal Bore	Carrera Stroke	COJINETE, BUJE O ARANDELA	No. de Parte	Ubicación Location
CYL.	YEAR	ENGINE / APPLICATION		 mm Pulgadas	 mm Pulgadas	BEARING, BUSHING OR THURST WASHER	Part Number	
L6	1963-90	292 (4.8L) Chevrolet OHV Vin "T" (4784 cc) Blazer, C20, C30, C1500, C2500, C3500, C5000, C6000, G20, G30, G2500, G3500, Jimmy, K20, K1500, K2500, K3500, P4, P10, P20, P30, P1500, P2500, P3500, R20, R30, R2500, R3500, V20, V30, V2500, V3500	98.43 3.875	104.78 4.125	COJINETE DE BIELA	6B663 STD 010 020 030 040	TODOS	
					COJINETE DE BANCADA	7C617 STD 010 020 030 040	1-2-3-4-5-6 (A, B)	
					BUJE DE ARBOL 1971-89	MO1557M STD 010	7 (C, D) 1-2-3-4	
V8	1975-82	260 (4.3L) Oldsmobile OHV (4300 cc) Apollo, Cutlass, Delta 88, Lemans, Omega, Skylark, Ventura	88.90 3.500	85.98 3.385	COJINETE DE BIELA	8B684 STD 010 020 030 040	TODOS	
					BUJE DE ARBOL	MO1466M STD	1	
	2							
	3							
	1968-80	350 (5.7L) Oldsmobile OHV (5700 cc) Catalina, Century, Custom Cruiser, Cutlass, Delta 88, Eldorado, Electra, Estate Wagon, F85, Grand Prix, Lemans, Ninety Eight, Seville, Toronado, Ventura, Vista Cruiser	103.05 4.057	85.98 3.385	4			
5								

Línea Line

26

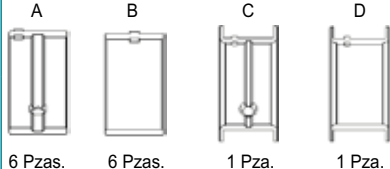

27

Diámetro Estándar del Muñón Standard Shaft Diameter	Diámetro Total del Alojamiento Housing Bore	Ancho del Cojinete Width Bearing	Espesor Máximo de Pared Max Wall Thickness	Claro de Lubricación Oil Clearance	Torque Torque	Imagen del Cojinete / Arandela Image of the Bearing and Thrust Washer
mm Pulgadas	mm Pulgadas	mm Pulgadas	mm Pulgadas	mm Pulgadas	N.m Lbs.Ft	
53.315/53.340 2.099/2.100	56.507/56.520 2.225/2.225	21.39 0.842	1.577 0.0621	0.0304/0.0939 0.0012/0.0037	40 a 47 N.m 30 a 35 Lbs.Ft	 12 Piezas
58.377/58.402 2.298/2.299	63.261/63.287 2.491/2.492	20.50 0.807	2.426 0.0955	0.0152/0.0914 0.0006/0.0036	81 a 95 N.m	 6 Pzas. 6 Pzas. 1 Pza. 1 Pza.
58.377/58.402 2.298/2.299	63.261/63.287 2.491/2.492	25.63 1.009	2.426 0.0955	0.0152/0.0914 0.0006/0.0036	60 a 70 Lbs.Ft	
47.452/47.478 1.868/1.869	50.775/50.825 1.999/2.001	21.97 0.865	1.636 0.0644	0.0127/0.1270 0.0005/0.0050		4 Piezas
53.944/53.969 2.124/2.125	57.137/57.150 2.249/2.250	21.11 0.831	1.572 0.0619	0.0355/0.0990 0.0014/0.0039	57 N.m 42 Lbs.Ft	 16 Piezas
51.727/51.747 2.037/2.037	55.067/55.105 2.168/2.170	17.60 0.693	1.641 0.0646	0.0508/0.1524 0.0020/0.0060		1 Pieza
51.219/51.239 2.017/2.017	54.559/54.597 2.148/2.150	17.48 0.688	1.641 0.0646	0.0508/0.1524 0.0020/0.0060		1 Pieza
50.711/50.731 1.997/1.997	54.051/54.089 2.128/2.130	17.48 0.688	1.641 0.0646	0.0508/0.1524 0.0020/0.0060		1 Pieza
50.203/50.223 1.977/1.977	53.543/53.581 2.108/2.110	17.48 0.688	1.641 0.0646	0.0508/0.1524 0.0020/0.0060		1 Pieza
49.695/49.715 1.957/1.957	53.035/53.073 2.088/2.090	17.48 0.688	1.641 0.0646	0.0508/0.1524 0.0020/0.0060		1 Pieza

GM CHEVROLET

MORESA!

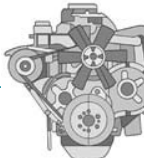
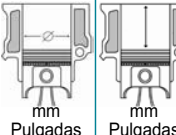
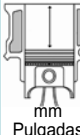
GM CHEVROLET BUICK OLDSMOBILE PONTIAC

CIL.	AÑO	MOTOR / APLICACIÓN		Diámetro del Cilindro Nominal Bore	Carrera Stroke	COJINETE, BUJE O ARANDELA	No. de Parte	Ubicación Location
CYL.	YEAR	ENGINE / APPLICATION		 mm Pulgadas	 mm Pulgadas	BEARING, BUSHING OR THURST WASHER	Part Number	
V8	1975-76	262 (4.3L) Chevrolet OHV Vin "G" (4291 cc) Monza, Nova	93.24 3.671	78.97 3.109			8B663 STD 010 020 030 040	TODOS
	1994-96	265 (4.3L) Chevrolet L99 OHV Vin "W" (4300 cc) Caprice	94.87 3.735	76.20 3.000	COJINETE DE BIELA 1968- 96			
	1979-82	267 (4.4L) Chevrolet OHV Vin "J" (4400 cc) Caballera, Camaro, Caprice, Century, Cutlass, El Camino, Impala, Laurentian, LeSabre, Malibu, Monte Carlo, Regal	88.90 3.500	88.49 3.484			5C909 STD 010 020 030 040	1-2-3-4 (A, B)
	1976-99	305 (5.0L) Chevrolet OHV (5000 cc)	94.89 3.736	88.49 3.484	COJINETE DE BANCADA			
	1968-73	307 (5.0L) Chevrolet OHV (5028 cc) Bel Air, Biscayne, Blazer, C10, C20, C30, C1500, C2500, C3500, Camaro, Caprice, Chevelle, Chevy II, El Camino, G10, G20, Jimmy, K10, K20, K1500, K2500, Nova, P10, P20, P30, P2500, P3500, Sprint, Suburban, Sprint, Ventura II	98.43 3.875	82.55 3.250				5 (C, D)
	1968-69	327 (5.4L) Chevrolet OHV Vin "L" (5356 cc) C10, C20, C30, CE50, CE60, Camaro, Caprice, Chevelle, Chevy II, Corvette, El Camino, Impala, K10, K20, ME50, P10, P20, P30, SE5000, Suburban, TE50	101.60 4.000	82.55 3.250			MO1235M STD 010 020 030	1 2-5 3-4

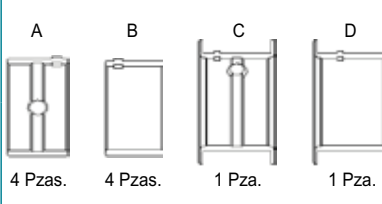

Línea Line

28

Diámetro Estándar del Muñón Standard Shaft Diameter	Diámetro Total del Alojamiento Housing Bore	Ancho del Cojinete Width Bearing	Esesor Máximo de Pared Max Wall Thickness	Claro de Lubricación Oil Clearance	Torque Torque	Imagen del Cojinete / Arandela Image of the Bearing and Thrust Washer
mm Pulgadas	mm Pulgadas	mm Pulgadas	mm Pulgadas	mm Pulgadas	N.m Lbs.Ft	
53.315/53.340 2.099/2.100	56.507/56.520 2.225/2.225	21.39 0.842	1.577 0.0621	0.0304/0.0939 0.0012/0.0037	47 N.m 35 Lbs.Ft Tornillos 11/32" 61 N.m 45 Lbs.Ft Tornillos 3/8"	
62.189/62.212 2.448/2.449	67.071/67.094 2.641/2.642	20.50 0.807	2.426 0.0955	0.0152/0.1524 0.0006/0.0036	102 N.m 75 Lbs.Ft	
62.177/62.200 2.448/2.449	67.071/67.094 2.641/2.642	43.64 1.718	2.426 0.0955	0.0279/0.1041 0.0011/0.0041		4 Pzas. 4 Pzas. 1 Pza. 1 Pza.
47.452/47.478 1.868/1.869	51.283/51.333 2.019/2.021	18.80 0.740	1.890 0.0744	0.0254/0.1270 0.0010/0.0050		1 Pieza
47.452/47.478 1.868/1.869	51.029/51.079 2.009/2.011	18.92 0.745	1.763 0.0694	0.0254/0.1270 0.0010/0.0050		1 Pieza
47.452/47.478 1.868/1.869	50.775/50.825 1.999/2.001	18.80 18.92	1.636 0.0644	0.0254/0.1270 0.0010/0.0050		1 Pieza

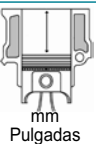

GM CHEVROLET

MORESA!

CIL.	AÑO	MOTOR / APLICACIÓN	Diámetro del Cilindro Nominal Bore	Carrera Stroke	COJINETE, BUJE O ARANDELA	No. de Parte	Ubicación Location
CYL.	YEAR	ENGINE / APPLICATION	 mm Pulgadas	 mm Pulgadas	BEARING, BUSHING OR THURST WASHER	Part Number	
V8	1980-81	265 (4.3L) Pontiac OHV Vin "S" (4300 cc) Bonneville, Catalina, Century, Delta 88, Firebird, Grand Prix, Laurentian, Lemans, Regal	95.25 3.750	76.20 3.000	COJINETE DE BIELA	8B610 STD 010 020	TODOS
	1977-81	301 (4.9L) Pontiac OHV (4900 cc) Bonneville, Catalina, Century, Delta 88, Electra, Estate Wagon, Firebird, Grand Am, Grand Prix, LeSabre, Lemans, Regal, Riviera, Skylark	101.60 4.000	76.20 3.000			
	1980-81	301 (4.9L) Pontiac Turbo OHV (4900 cc) Firebird	101.60 4.000	76.20 3.000			
	1968-81	350 (5.7L) Buick OHV Type B (5700 cc) Apollo, Bonneville, Catalina, Centurian, Century, Electra, Estate Wagon, Gran Sport, Laurentian, Lemans, Regal, Riviera, Skylark, Special, Ventura	96.52 3.800	97.79 3.850			
V8	1957-67	283 (4.6L) Chevrolet OHV (4635 cc) Beauville, Bel Air, Biscayne, Brookwood, C10, C20, C30, Camaro, Caprice, Chevelle, Chevy II, Corvette, Del Ray, Deluxe 210, El Camino, G10, G20, G1500, G2500, Impala, K10, K20, Special 150, Suburban, Townsman	98.43 3.875	76.20 3.000	COJINETE DE BIELA	8B745 STD 010 020 030 040	TODOS
					BUJE DE ARBOL 1964-67	MO1235M STD 010 020 030	1
							2-5
							3-4

Línea Line
29



30

Diámetro Estándar del Muñón Standard Shaft Diameter	Diámetro Total del Alojamiento Housing Bore	Ancho del Cojinete Width Bearing	Espesor Máximo de Pared Max Wall Thickness	Claro de Lubricación Oil Clearance	Torque Torque	Imagen del Cojinete / Arandela Image of the Bearing and Thrust Washer
mm Pulgadas	mm Pulgadas	mm Pulgadas	mm Pulgadas	mm Pulgadas	N.m Lbs.Ft	
50.787/50.813 2.000/2.001	53.967/53.980 2.125/2.125	18.85 0.742	1.575 0.0620	0.0177/0.0812 0.0007/0.0032	38 N.m 28 Lbs.Ft (301 4.9L) 47 N.m 35 Lbs.Ft (265 4.3L LS5) (301 4.9L L27) 41 a 54 N.m 30 a 40 Lbs.Ft (4.9L) 47 N.m 35 Lbs.Ft (5.7L)	 16 Piezas
50.775/50.800 1.999/2.000	53.967/53.980 2.125/2.125	21.39 0.842	1.577 0.0621	0.0254/0.0889 0.0010/0.0035	47 N.m 35 Lbs.Ft Tornillos 11/32" 61 N.m 45 Lbs.Ft Tornillos 3/8"	 16 Piezas
47.452/47.478 1.868/1.869	51.283/51.333 2.019/2.021	18.80 0.740	1.890 0.0744	0.0254/0.1270 0.0010/0.0050		1 Pieza
47.452/47.478 1.868/1.869	51.029/51.079 2.009/2.011	18.92 0.745	1.763 0.0694	0.0254/0.1270 0.0010/0.0050		1 Pieza
47.452/47.478 1.868/1.869	50.775/50.825 1.999/2.001	18.80 0.740	1.636 0.0644	0.0254/0.1270 0.0010/0.0050		1 Pieza

GM CHEVROLET

MORESA!

GM CHEVROLET BUICK OLDSMOBILE PONTIAC



CIL.	AÑO	MOTOR / APLICACIÓN		Diámetro del Cilindro Nominal Bore	Carrera Stroke	COJINETE, BUJE O ARANDELA	No. de Parte	Ubicación Location
CYL.	YEAR	ENGINE / APPLICATION		mm Pulgadas	mm Pulgadas	BEARING, BUSHING OR THURST WASHER	Part Number	
31	V8	1999-06	293 (4.8L) Chevrolet Vortec OHV Gen III (4800 cc) Express, Savana, Sierra, Silverado, Suburban, Tahoe, Yukon	96.00 3.780	83.01 3.268	COJINETE DE BIELA	8B663 STD 010 020 030 040	TODOS
	1999-06	325 (5.3L) Chevrolet Vortec OHV Gen III(5300 cc) Avalanche, Envoy, Escalade, Express, Grand Prix, Rainier, Savana, Sierra, Silverado, Suburban, Tahoe, Trailblazer, Yukon	96.00 3.780	92.00 3.622				
	1997-04	346 (5.7L) Chevrolet LS1 Vortec OHV Gen III (5700 cc) Camaro, Corvette, Fierbird, GTO	99.01 3.898	92.00 3.622	COJINETE DE BANCADA	5C2199 STD 010 020 030	1-2-4-5 (A, B)	
	2001-06	346 (5.7L) Chevrolet LS6 Vortec OHV Gen III (5700 cc) CTS-V, Corvette	99.01 3.898	92.00 3.622				
	1999-06	365 (6.0L) Chevrolet Vortec OHV Gen III (6000 cc) CTS-V, Escalade, Express, GTO, Hummer H2, SSR, Savana, Sierra, Silverado, Suburban, Trailblazer, Yukon	101.60 4.000	92.08 3.625			3 (C, D)	
32	V8	1964-67	300 (4.9L) Buick OHV (4914 cc) LeSabre, Riviera, Skylark, Special	95.25 3.750	86.36 3.400	COJINETE DE BIELA	8B610 STD 010 020	TODOS
	1966-67	340 (5.6L) Buick OHV Vin "B" (5569 cc) LeSabre, Special	95.25 3.750	97.79 3.850				
						BUJE DE ARBOL	MO1421M STD	1
								2
								3
					4			
							5	

Diámetro Estándar del Muñón Standard Shaft Diameter	Diámetro Total del Alojamiento Housing Bore	Ancho del Cojinete Width Bearing	Esesor Máximo de Pared Max Wall Thickness	Claro de Lubricación Oil Clearance	Torque Torque	Imagen del Cojinete / Arandela Image of the Bearing and Thrust Washer
53.315/53.340 2.099/2.100	56.507/56.520 2.225/2.225	21.39 0.842	1.577 0.0621	0.0304/0.0939 0.0012/0.0037	47 N.m 35 Lbs.Ft Tornillos 11/32" 61 N.m 45 Lbs.Ft Tornillos 3/8"	 16 Piezas
64.994/65.006 2.559/2.559	69.873/69.886 2.751/2.751	20.45 0.805	2.426 0.0955	0.0050/0.0457 0.0002/0.0018	Interno 20 N.m + 80° Externo 20 N.m + 53° Laterales 24 N.m	
64.994/65.006 2.559/2.559	69.873/69.886 2.751/2.751	26.09 1.027	2.426 0.0955	0.0050/0.0457 0.0002/0.0018	Interno 15 Lbs.Ft + 80° Externo 15 Lbs.Ft + 53° Laterales 18 Lbs.Ft	4 Pzas. 4 Pzas. 1 Pza. 1 Pza.
50.787/50.813 2.000/2.001	53.967/53.980 2.125/2.125	18.85 0.742	1.575 0.062	0.0177/0.0812 0.0007/0.0032	38 N.m 28 Lbs.Ft (301 4.9L) 47 N.m 35 Lbs.Ft (265 4.3L LS5) (301 4.9L L27) 41 a 54 N.m 30 a 40 Lbs.Ft (4.9L) 47 N.m 35 Lbs.Ft (5.7L)	 16 Piezas
45.339/45.364 1.785/1.786	48.654/48.705 1.916/1.918	19.30 0.760	1.633 0.0643	0.0127/0.1397 0.0005/0.0055		1 Pieza
44.577/44.602 1.755/1.756	47.892/47.943 1.886/1.888	19.30 0.760	1.633 0.0643	0.0254/0.1524 0.0010/0.0060		1 Pieza
43.815/43.840 1.725/1.726	47.130/47.181 1.856/1.858	19.30 0.760	1.633 0.0643	0.0254/0.1524 0.0010/0.0060		1 Pieza
43.053/43.078 1.695/1.696	46.368/46.419 1.826/1.828	19.30 0.760	1.633 0.0643	0.0254/0.1524 0.0010/0.0060		1 Pieza
42.294/42.316 1.665/1.666	45.606/45.657 1.796/1.798	19.30 0.760	1.633 0.0643	0.0254/0.1524 0.0010/0.0060		1 Pieza

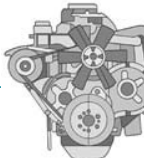
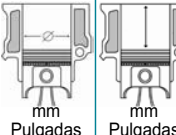
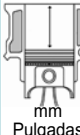

GM CHEVROLET

MORESA

GM CHEVROLET BUICK OLDSMOBILE PONTIAC

CIL.	AÑO	MOTOR / APLICACIÓN		Diámetro del Cilindro Nominal Bore	Carrera Stroke	COJINETE, BUJE O ARANDELA	No. de Parte	Ubicación Location	
CYL.	YEAR	ENGINE / APPLICATION		 mm Pulgadas	 mm Pulgadas	BEARING, BUSHING OR THURST WASHER	Part Number		
V8	1967-69	302 (4.9L) Chevrolet OHV (4946 cc) Camaro	101.60 4.000	76.20 3.000	COJINETE DE BIELA 1968-69	8B663	STD 010 020 030 040	TODOS	
	1962-69	327 (5.4L) Chevrolet OHV (5354 cc) Bel Air, Biscayne, C10, C20, C30, CE50, CE60, Caprice, Chevelle, Chevy II, Corvette, El Camino, Impala, K10, K20, ME50, P10, P20, P30, S6200, SE5000, SE6000, Suburban, TE50	101.60 4.000	82.55 3.250	1967-02 350 Chevrolet OHV, Inc. LT1, Exc. DOHC				
	1967-02	350 (5.7L) Chevrolet OHV, Inc. LT1, Exc. DOHC (5700 cc) Bel Air, Biscayne, Blazer, Bonneville, Brougham, C10, C20, C30, C50, C60, C1500, C2500, C3500, C5000, C6000, CE40, CE50, CE60, Caballera, Camaro, Caprice, Catalina, Century, Chevelle, Corvette, Custom Cruiser, Cutl, El Camino, Escalade, Express, Firebird, Fleetwood, G10, G20, G30, G1500, G2500, G3500, Impala, Jimmy, K10, K20, K30, K1500, K2500, K3500, Laurentian, LeSabre, Lemans, ME50, Malibu, Monte Carlo, Monza, Nova, Omega, P6, P10, P20, P30, P2500, P3500, Phoenix, R10, R20, R30, R1500, R2500, R3500, Regal, Riviera, Roadmaster, SE50, SE60, Sierra, Sonoma, Skylark, Sprint, Suburban, TE50, TE60, V10, V20, V30, V1500, V2500, V3500, Ventura, W6, Yukon	101.60 4.000	88.39 3.480	COJINETE DE BIELA 1967 302 Chevrolet OHV 1962-67 327 Chevrolet OHV	8B745	STD 010 020 030 040	TODOS	
					COJINETE DE BANCADA 1968-69 1967-02 350 Chevrolet OHV, Inc. LT1, Exc. DOHC	5C909			1-2-3-4 (A, B)
					BUJE DE ARBOL 1964-69 327 Chevrolet OHV	MO1235M	1	2-5	3-4



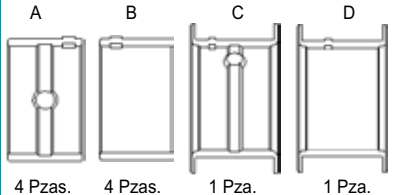

Línea Line
33

Diámetro Estándar del Muñón Standard Shaft Diameter	Diámetro Total del Alojamiento Housing Bore	Ancho del Cojinete Width Bearing	Espesor Máximo de Pared Max Wall Thickness	Claro de Lubricación Oil Clearance	Torque Torque	Imagen del Cojinete / Arandela Image of the Bearing and Thrust Washer
mm Pulgadas	mm Pulgadas	mm Pulgadas	mm Pulgadas	mm Pulgadas	N.m Lbs.Ft	
53.315/53.340 2.099/2.100	56.507/56.520 2.225/2.225	21.39 0.842	1.577 0.0621	0.0304/0.0939 0.0012/0.0037	47 N.m 35 Lbs.Ft Tornillos 11/32" 61 N.m 45 Lbs.Ft Tornillos 3/8"	 16 Piezas
50.775/50.800 1.999/2.000	53.967/53.980 2.125/2.125	21.39 0.842	1.577 0.0621	0.0254/0.0889 0.0010/0.0035	47 N.m 35 Lbs.Ft Tornillos 11/32" 61 N.m 45 Lbs.Ft Tornillos 3/8"	 16 Piezas
62.189/62.212 2.448/2.449	67.071/67.094 2.641/2.642	20.50 0.807	2.426 0.0955	0.0152/0.0914 0.0006/0.0036	102 N.m 75 Lbs.Ft	 4 Pzas. 4 Pzas. 1 Pza. 1 Pza.
62.177/62.200 2.448/2.449	67.071/67.094 2.641/2.642	43.64 1.718	2.426 0.0955	0.0279/0.1041 0.0011/0.0041		
47.452/47.478 1.868/1.869	51.283/51.333 2.019/2.021	18.80 0.740	1.890 0.0744	0.0254/0.1270 0.0010/0.0050		1 Pieza
47.452/47.478 1.868/1.869	51.029/51.079 2.009/2.011	18.92 0.745	1.763 0.0694	0.0254/0.1270 0.0010/0.0050		2 Piezas
47.452/47.478 1.868/1.869	50.775/50.825 1.999/2.001	18.80 0.740	1.636 0.0644	0.0254/0.1270 0.0010/0.0050		2 Piezas

GM CHEVROLET

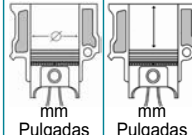
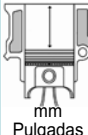
MORESA!

GM CHEVROLET BUICK OLDSMOBILE PONTIAC

CIL.	AÑO	MOTOR / APLICACIÓN		Diámetro del Cilindro Nominal Bore	Carrera Stroke	COJINETE, BUJE O ARANDELA	No. de Parte	Ubicación Location
CYL.	YEAR	ENGINE / APPLICATION		 mm Pulgadas	 mm Pulgadas	BEARING, BUSHING OR THURST WASHER	Part Number	
34	V8	1980-90 307 (5.0L) Oldsmobile OHV (5000 cc) Bonneville, Caprice, Catalina, Custom Cruiser, Cutlass, Delta 88, Electra, Fleetwood, Laurentian, LeSabre, Monte Carlo, Ninety Eight, Parisienne, Regal, Regency, Riviera, Safari		96.52 3.800	85.98 3.385	COJINETE DE BIELA	8B684 STD 010 020 030 040	TODOS
						BUJE DE ARBOL	MO1466M STD	1
								2
								3
								4
5								
35	V8	1964-67 330 (5.4L) Oldsmobile OHV , Second Series Vin "O" (5405 cc) Cutlass, Delmont Eighty Eight, F85, Jetstar 88		100.03 3.938	85.95 3.385	COJINETE DE BIELA	8B684 STD 010 020 030 040	TODOS
36	V8	1958-65 348 (5.7L) Chevrolet OHV (5700 cc) Bel Air, Biscayne, Brookwood, Del Ray, Impala, M70, M80, S70, T70, T80, Yeoman		104.78 4.125	82.55 3.250	COJINETE DE BIELA	8B663 STD 010 020 030 040	TODOS
						COJINETE DE BIELA	8B743 STD 010 020 030 040	TODOS

Diámetro Estándar del Muñón Standard Shaft Diameter	Diámetro Total del Alojamiento Housing Bore	Ancho del Cojinete Width Bearing	Espesor Máximo de Pared Max Wall Thickness	Claro de Lubricación Oil Clearance	Torque Torque	Imagen del Cojinete / Arandela Image of the Bearing and Thrust Washer
53.944/53.969 2.124/2.125	57.137/57.150 2.249/2.250	21.11 0.831	1.572 0.0619	0.0355/0.0990 0.0014/0.0039	57 N.m 42 Lbs.Ft	 16 Piezas
51.727/51.747 2.037/2.037	55.067/55.105 2.168/2.170	17.60 0.693	1.641 0.0646	0.0508/0.1524 0.0020/0.0060		1 Pieza
51.219/51.239 2.017/2.017	54.559/54.597 2.148/2.150	17.48 0.688	1.641 0.0646	0.0508/0.1524 0.0020/0.0060		1 Pieza
50.711/50.731 1.997/1.997	54.051/54.089 2.128/2.130	17.48 0.688	1.641 0.0646	0.0508/0.1524 0.0020/0.0060		1 Pieza
50.203/50.223 1.977/1.977	53.543/53.581 2.108/2.110	17.48 0.688	1.641 0.0646	0.0508/0.1524 0.0020/0.0060		1 Pieza
49.695/49.715 1.957/1.957	53.035/53.073 2.088/2.090	17.48 0.688	1.641 0.0646	0.0508/0.1524 0.0020/0.0060		1 Pieza
53.944/53.969 2.1238/2.1248	57.137/57.150 2.2495/2.2500	21.11 0.831	1.572 0.0619	0.0355/0.0990 0.0014/0.0039	57 N.m 42 Lbs.Ft	 16 Piezas
53.315/53.340 2.099/2.100	56.507/56.520 2.225/2.225	21.39 0.842	1.577 0.0621	0.0304/0.0939 0.0012/0.0037	47 N.m 35 Lbs.Ft Tornillos 11/32" 61 N.m 45 Lbs.Ft Tornillos 3/8"	 16 Piezas
55.855/55.880 2.199/2.200	59.047/59.060 2.325/2.325	22.66 0.892	1.580 0.0622	0.0304/0.0939 0.0012/0.0037	61 a 75 N.m 45 a 55 Lbs.Ft	 16 Piezas

GM CHEVROLET

MORESA

GM CHEVROLET BUICK OLDSMOBILE PONTIAC

CIL.	AÑO	MOTOR / APLICACIÓN	Diámetro del Cilindro Nominal Bore	Carrera Stroke	COJINETE, BUJE O ARANDELA	No. de Parte	Ubicación Location
CYL.	YEAR	ENGINE / APPLICATION	mm Pulgadas	mm Pulgadas	BEARING, BUSHING OR THURST WASHER	Part Number	→ 1 2 3 4 5
V8	1966-00	366 (6.0L) Chevrolet OHV (6000 cc) B6, B6000, B7000, C50, C60, C65, C70, C80, C5500, C6000, C7000, C7500, C8500, Kodiak, L60, L80, M60, S60, T60, T80, T6500, T7500, T8500, W6, W7	100.03 3.938	95.50 3.760	COJINETE DE BIELA	8B743 STD 010 020 030 040	TODOS
	1965-70	396 (6.5L) Chevrolet OHV (6488 cc) Bel Air, Biscayne, C10, C20, C30, C1500, C2500, C3500, Camaro, Caprice, Chevelle, Corvette, El Camino, Impala, K10, K20, K30, K1500, K2500, K3500, Nova, Suburban	103.99 4.094	95.50 3.760			
	1970-72	402 (6.6L) Chevrolet OHV (6587 cc) C1500, C2500, C3500, Camaro, Caprice, Chevelle, El Camino, Impala, Monte Carlo, Sprint, Suburban	104.78 4.125	95.50 3.760	COJINETE DE BANCADA	5C829 STD 010 020 030 040	1-2-3-4 (A, B)
	1966-00	427 (7.0L) Chevrolet OHV (7000 cc) B6, B6000, B7000, Bel Air, Biscayne, C50, C60, C65, C70, C80, C5500, C6000, C7000, C7500, C8500, Camaro, Caprice, Corvette, Impala, Kodiak, W7	107.98 4.251	95.50 3.760			5 (C, D)
	1970-00	454 (7.4L) Chevrolet OHV (7400 cc) B7500, Bel Air, Biscayne, Blazer, C10, C20, C30, C1500, C2500, C3500, C6500, C7500, C8500, C50, C60, C65, C70, C80, C5500, C6000, C7000, C7500, C8500, Camaro, Caprice, Chevelle, Corvette, El Camino, Express 3500, G30, G3500, Jimmy, K10, K10, K20, K30, K1500, K20, K30, K1500, K2500, K3500, K2500, K3500, Nova, Suburban, Monte Carlo, P20, P30, P2500, P3500, R20, R30, R1500, R2500, R3500, Savana, Sierra, Sprint, V20, V30, V2500, V3500	107.25 4.250	101.60 4.000	BUJE DE ARBOL 1967-95	MO1404M STD 010	1 2-5
	1990-01	502 (8.2L) Chevrolet Gen IV, V, VI OHV (8200 cc) Marine, Performance	113.44 4.466	101.60 4.000			3-4

Línea Line

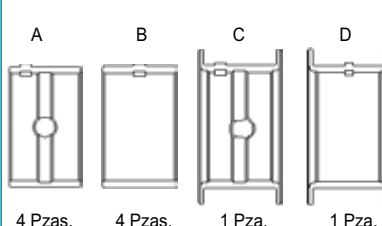

37

Diámetro Estándar del Muñón Standard Shaft Diameter	Diámetro Total del Alojamiento Housing Bore	Ancho del Cojinete Width Bearing	Espesor Máximo de Pared Max Wall Thickness	Claro de Lubricación Oil Clearance	Torque Torque	Imagen del Cojinete / Arandela Image of the Bearing and Thrust Washer
mm Pulgadas	mm Pulgadas	mm Pulgadas	mm Pulgadas	mm Pulgadas	N.m Lbs.Ft	
55.855/55.880 2.199/2.200	59.047/59.060 2.325/2.325	22.66 0.892	1.580 0.0622	0.0304/0.0939 0.0012/0.0037	61 a 75 N.m 45 a 55 Lbs.Ft	 16 Piezas
69.812/69.837 2.749/2.750	74.600/74.625 2.937/2.938	26.52 1.044	2.377 0.0936	0.0177/0.0812 0.0007/0.0032	122 a 136 N.m 90 a 100 Lbs.Ft	
69.794/69.820 2.748/2.749	74.600/74.625 2.937/2.938	46.00 1.811	2.377 0.0936	0.0228/0.0990 0.0009/0.0039	149 a 163 N.m 110 a 120 Lbs.Ft (KODIAK)	4 Pzas. 4 Pzas. 1 Pza. 1 Pza.
49.497/49.522 1.949/1.950	54.343/54.369 2.140/2.141	22.10 0.870	2.390 0.0941	0.0152/0.1168 0.0006/0.0046		1 Pieza
49.497/49.522 1.949/1.950	54.089/54.115 2.130/2.131	25.15 0.990	2.263 0.0891	0.0152/0.1168 0.0006/0.0046		2 Piezas
49.497/49.522 1.949/1.950	53.835/53.861 2.120/2.121	25.15 0.990	2.136 0.0841	0.0152/0.1168 0.0006/0.0046		2 Piezas

GM CHEVROLET

MORESA!

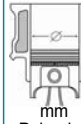
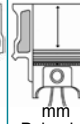
GM CHEVROLET BUICK OLDSMOBILE PONTIAC

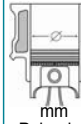
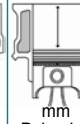
CIL.	AÑO	MOTOR / APLICACIÓN		Diámetro del Cilindro Nominal Bore	Carrera Stroke	COJINETE, BUJE O ARANDELA	No. de Parte	Ubicación Location
CYL.	YEAR	ENGINE / APPLICATION		 mm Pulgadas	 mm Pulgadas	BEARING, BUSHING OR THURST WASHER	Part Number	
V8	1970-80	400 (6.6L) Chevrolet OHV (6600 cc) Bel Air, Biscayne, Blazer, Bonneville, Caprice, El Camino, G30, G3500, Grand Prix, Impala, Jimmy, K10, K20, K30, K1500, K2500, K3500, Monte Carlo, Sprint, Suburban	 mm Pulgadas 104.80 4.126	 mm Pulgadas 95.25 3.750	COJINETE DE BIELA	8B663 STD 010 020 030	TODOS	
					COJINETE DE BANCADA	5C1038 STD 010 020 030 040	1-2-3-4 (A, B)	
							5 (C, D)	
					BUJE DE ARBOL	MO1235M STD 010 020 030	1	
							2-5	
							3-4	

Línea Line

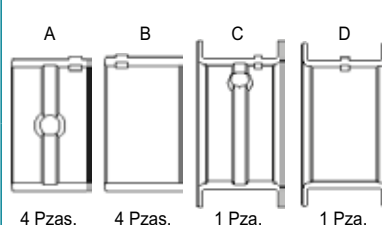

38





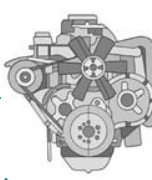
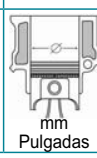
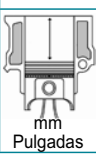

Diámetro Estándar del Muñón Standard Shaft Diameter	Diámetro Total del Alojamiento Housing Bore	Ancho del Cojinete Width Bearing	Esesor Máximo de Pared Max Wall Thickness	Claro de Lubricación Oil Clearance	Torque Torque	Imagen del Cojinete / Arandela Image of the Bearing and Thrust Washer
mm Pulgadas	mm Pulgadas	mm Pulgadas	mm Pulgadas	mm Pulgadas	N.m Lbs.Ft	
53.315/53.340 2.099/2.100	56.507/56.520 2.225/2.225	21.39 0.842	1.577 0.0621	0.0304/0.0939 0.0012/0.0037	47 N.m 35 Lbs.Ft Tornillos 11/32" 61 N.m 45 Lbs.Ft Tornillos 3/8"	
67.269/67.292 2.648/2.649	72.151/72.174 2.841/2.842	20.50 0.807	2.426 0.0955	0.0152/0.0863 0.0006/0.0034	102 N.m 75 Lbs.Ft	
67.257/67.280 2.648/2.649	72.151/72.174 2.841/2.842	43.64 1.718	2.426 0.0955	0.0279/0.0990 0.0011/0.0039		4 Pzas. 4 Pzas. 1 Pza. 1 Pza.
47.452/47.478 1.868/1.869	51.283/51.333 2.019/2.021	18.80 0.740	1.890 0.0744	0.0254/0.1270 0.0010/0.0050		1 Pieza
47.452/47.478 1.868/1.869	51.029/51.079 2.009/2.011	18.92 0.745	1.763 0.0694	0.0254/0.1270 0.0010/0.0050		2 Piezas
47.452/47.478 1.868/1.869	50.775/50.825 1.999/2.001	18.80 0.740	1.636 0.0644	0.0254/0.1270 0.0010/0.0050		2 Piezas

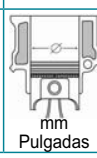
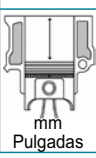
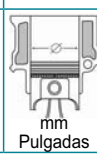
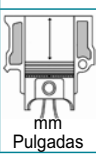
GM CHEVROLET

MORESA!

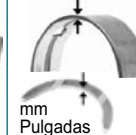
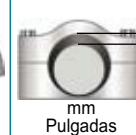
GM CHEVROLET BUICK OLDSMOBILE PONTIAC



CIL.	AÑO	MOTOR / APLICACIÓN		Diámetro del Cilindro Nominal Bore	Carrera Stroke	COJINETE, BUJE O ARANDELA	No. de Parte	Ubicación Location	
CYL.	YEAR	ENGINE / APPLICATION				BEARING, BUSHING OR THURST WASHER	Part Number		
39	V8 1977-79	403 (6.6L) Oldsmobile OHV (6600 cc) Bonneville, Catalina, Century, Custom Cruiser, Cutlass, Delta 88, Electra, Estate Wagon, Firebird, Grand Prix, LeSabre, Lemans, Ninety Eight, Regal, Riviera, Toronado			110.52 4.351	85.98 3.385	COJINETE DE BIELA 	8B684 STD 010 020 030 040	TODOS
									1
									2
									3
									4
									5
40	V8 2001-05	496 (8.1L) Chevrolet Vortec OHV (8100 cc) Avalanche, Express, Silverado, Suburban, 3500HD, Kodiak			107.95 4.250	111.00 4.370	COJINETE DE BIELA 	8B743 STD 010 020 030 040	TODOS
									1
									2-5
									3-4

Diámetro Estándar del Muñón Standard Shaft Diameter	Diámetro Total del Alojamiento Housing Bore	Ancho del Cojinete Width Bearing	Espesor Máximo de Pared Max Wall Thickness	Claro de Lubricación Oil Clearance	Torque Torque	Imagen del Cojinete / Arandela Image of the Bearing and Thrust Washer
						
mm Pulgadas	mm Pulgadas	mm Pulgadas	mm Pulgadas	mm Pulgadas	N.m Lbs.Ft	
53.944/53.969 2.124/2.125	57.137/57.150 2.249/2.250	21.11 0.831	1.572 0.0619	0.0355/0.0990 0.0014/0.0039	57 N.m 42 Lbs.Ft	 16 Piezas
51.727/51.747 2.037/2.037	55.067/55.105 2.168/2.170	17.60 0.693	1.641 0.0646	0.0508/0.1524 0.0020/0.0060		1 Pieza
51.219/51.239 2.017/2.017	54.559/54.597 2.148/2.150	17.48 0.688	1.641 0.0646	0.0508/0.1524 0.0020/0.0060		1 Pieza
50.711/50.731 1.997/1.997	54.051/54.089 2.128/2.130	17.48 0.688	1.641 0.0646	0.0508/0.1524 0.0020/0.0060		1 Pieza
50.203/50.223 1.977/1.977	53.543/53.581 2.108/2.110	17.48 0.688	1.641 0.0646	0.0508/0.1524 0.0020/0.0060		1 Pieza
49.695/49.715 1.957/1.957	53.035/53.073 2.088/2.090	17.48 0.688	1.641 0.0646	0.0508/0.1524 0.0020/0.0060		1 Pieza
55.855/55.880 2.199/2.200	59.047/59.060 2.325/2.325	22.66 0.892	1.580 0.0622	0.0304/0.0939 0.0012/0.0037	61 a 75 N.m 45 a 55 Lbs.Ft	 16 Piezas
49.497/49.522 1.949/1.950	54.343/54.369 2.140/2.141	22.10 0.870	2.390 0.0941	0.0152/0.1168 0.0006/0.0046		1 Pieza
49.497/49.522 1.949/1.950	54.089/54.115 2.130/2.131	25.15 0.990	2.263 0.0891	0.0152/0.1168 0.0006/0.0046		2 Piezas
49.497/49.522 1.949/1.950	53.835/53.861 2.120/2.121	25.15 0.990	2.136 0.0841	0.0152/0.1168 0.0006/0.0046		2 Piezas

HONDA

MORESA!

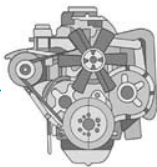
4 CILINDROS / 4 CYLINDER		
MOTOR / ENGINE	AÑO / YEAR	LINEA / LINE
EB1 (1.2L) SOHC 8 valve	1973	1
EB2,EB3 (1.2L) SOHC 8 valve	1974-79	1
EE (1.2L) SOHC 8 valve	1975-79	1
EJ1 (1.3L) SOHC 8 valve	1980-83	1
EN (1.3L) SOHC 8 valve	1979-83	1
EV2 (1.3L) SOHC 8 valve	1983-87	2
ED1,ED2,ED3,ED4 (1.5L) SOHC 8 valve	1974-78	3
EM1 (1.5L) SOHC 8 valve	1979-83	3

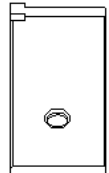
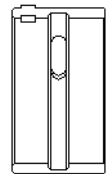

CIL.	AÑO	MOTOR / APLICACIÓN		Diámetro del Cilindro	Carrera	COJINETE, BUJE O ARANDELA	No. de Parte	Ubicación
				Nominal Bore	Stroke			
CYL.	YEAR	ENGINE / APPLICATION		mm Pulgadas	mm Pulgadas	BEARING, BUSHING OR THURST WASHER	Part Number	
1	L4	1973	EB1 (1.2L) SOHC 8 valve (1169 cc) Civic	70.00 2.756	76.00 2.992	COJINETE DE BIELA	4B1222 STD 010 020 030	→ 1 2 3 4 5 TODOS
		1974-79	EB2,EB3 (1.2L) SOHC 8 valve (1237 cc) Civic	72.01 2.835	76.00 2.992			
		1975-79	EE (1.2L) SOHC 8 valve (1238 cc) Civic	72.00 2.835	76.00 2.992			
		1980-83	EJ1 (1.3L) SOHC 8 valve (1335 cc) Civic	72.01 2.835	81.99 3.228	COJINETE DE BANCADA	5C1431 STD 010 020 030	TODOS
		1979-83	EN (1.3L) SOHC 8 valve (1335 cc)	72.01 2.835	81.99 3.228			
								ARANDELA

4 CILINDROS / 4 CYLINDER		
MOTOR / ENGINE	AÑO / YEAR	LINEA / LINE
EM1 (1.5L) SOHC 8 valve	1979-83	2
EW1,EW3,EW4 (1.5L) SOHC 12 valve	1984-86	2
ED1,ED2,ED3,ED4 (1.5L) SOHC 8 valve	1974-78	2
EF1 (1.6L) SOHC 8 valve	1976-86	3
EP (1.6L) SOHC 8 valve	1980-86	3
EF1 (1.6L) SOHC 8 valve	1976-86	2
EK,EK1 (1.8L) SOHC 8 valve	1978-83	2
EK,EK1 (1.8L) SOHC 8 valve	1978-83	3

Diámetro Estándar del Muñón Standard Shaft Diameter	Diámetro Total del Alojamiento Housing Bore	Ancho del Cojinete Width Bearing	Espesor Máximo de Pared Max Wall Thickness	Claro de Lubricación Oil Clearance	Torque Torque	Imagen del Cojinete / Arandela Image of the Bearing and Thurst Washer
mm Pulgadas	mm Pulgadas	mm Pulgadas	mm Pulgadas	mm Pulgadas	N.m Lbs.Ft	
39.977/40.000 1.574/1.575	43.000/43.025 1.693/1.694	17.50 0.689	1.501 0.0591	0.0127/0.0863 0.0005/0.0034	24 a 28 N.m 18 a 21 Lbs.Ft	 8 Piezas
49.977/50.000 1.968/1.969	54.000/54.023 2.126/2.127	19.99 0.787	1.999 0.0787	0.0228/0.0431 0.0009/0.0017	37 a 42 N.m 27 a 31 Lbs.Ft	 10 Piezas
55.999/56.251 2.205/2.215	78.001/78.250 3.071/3.081		2.499 0.0984			2 Piezas

HONDA

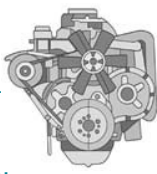
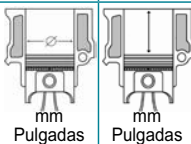
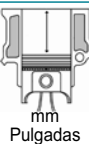
MORESA!

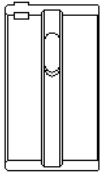
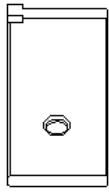
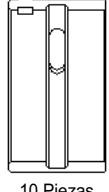

CIL.	AÑO	MOTOR / APLICACIÓN		Diámetro del Cilindro Nominal Bore	Carrera Stroke	COJINETE, BUJE O ARANDELA	No. de Parte	Ubicación Location
CYL.	YEAR	ENGINE / APPLICATION		 mm Pulgadas	 mm Pulgadas	BEARING, BUSHING OR THURST WASHER	Part Number	
2	L4							
	1983-87	EV2 (1.3L) SOHC 8 valve (1342 cc) CRX -1300, Civic (Standard)	73.99 2.913	78.00 3.071				
	1979-83	EM1 (1.5L) SOHC 8 valve (1488 cc) Civic, CRX	73.99 2.913	86.39 3.401	COJINETE DE BANCADA	5C1431 STD 010 020 030	TODOS	
	1984-86	EW1,EW3,EW4 (1.5L) SOHC 12 valve (1488 cc) CRX, CRX DX, CRX Si, Civic 2WD Wagon, Civic 4WD Wagon, Civic S, Civic Si	73.99 2.913	86.39 3.401				
	1974-78	ED1,ED2,ED3,ED4 (1.5L) SOHC 8 valve (1488 cc) Civic	73.99 2.913	86.00 3.386				
	1976-86	EF1 (1.6L) SOHC 8 valve (1599 cc) Accord, Civic	73.99 2.913	92.99 3.661	COJINETE DE BANCADA	AM327 STD	1	
	1978-83	EK,EK1 (1.8L) SOHC 8 valve (1750 cc) Accord, Prelude	77.01 3.032	94.01 3.701				
3	L4							
	1974-78	ED1,ED2,ED3,ED4 (1.5L) SOHC 8 valve (1488 cc) Civic	73.99 2.913	86.39 3.401	COJINETE DE BIELA	4B1223 STD 010 020 030	TODOS	
	1979-83	EM1 (1.5L) SOHC 8 valve (1488 cc) Civic, CRX	73.99 2.913	86.39 3.401				
	1976-86	EF1 (1.6L) SOHC 8 valve (1599 cc) Accord, Civic	73.99 2.913	92.99 3.661	COJINETE DE BANCADA	5C1431 STD 010 020 030	TODOS	
	1980-86	EP (1.6L) SOHC 8 valve (1601 cc) Civic	77.00 3.032	86.00 3.386				
1978-83	EK,EK1 (1.8L) SOHC 8 valve (1750 cc) Accord, Prelude	77.00 3.032	94.00 3.701	ARANDELA	AM327 STD	1		







Diámetro Estándar del Muñón Standard Shaft Diameter	Diámetro Total del Alojamiento Housing Bore	Ancho del Cojinete Width Bearing	Esesor Máximo de Pared Max Wall Thickness	Claro de Lubricación Oil Clearance	Torque Torque	Imagen del Cojinete / Arandela Image of the Bearing and Thrust Washer
mm Pulgadas	mm Pulgadas	mm Pulgadas	mm Pulgadas	mm Pulgadas	N.m Lbs.Ft	
49.977/50.000 1.968/1.969	54.000/54.023 2.126/2.127	19.99 0.787	1.999 0.0787	0.0228/0.0431 0.0009/0.0017	37 a 42 N.m 27 a 31 Lbs.Ft	 10 Piezas
55.999/56.251 2.205/2.215	78.001/78.250 3.071/3.081		2.499 0.0984			2 Piezas
41.976/41.999 1.653/1.654	45.001/45.024 1.772/1.773	17.50 0.689	1.499 0.0590	0.0127/0.0863 0.0005/0.0034	24 a 28 N.m 18 a 21 Lbs.Ft	 8 Piezas
49.977/50.000 1.968/1.969	54.000/54.023 2.126/2.127	19.99 0.787	1.999 0.0787	0.0228/0.0431 0.0009/0.0017	41 a 47 N.m 30 a 35 Lbs.Ft	 10 Piezas
55.999/56.251 2.205/ 2.215	78.001/78.250 3.071/ 3.081		2.499 0.0984			2 Piezas

HYUNDAI

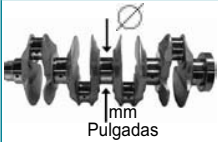
MORESA!

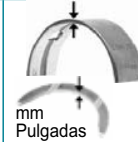
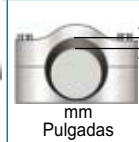
4 CILINDROS / 4 CYLINDER		
MOTOR / ENGINE	AÑO / YEAR	LINEA / LINE
G4HC (1.0L)	2000-04	1
1086cc (1.1L) SOHC 12V	2004-08	1

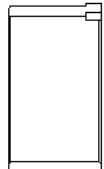
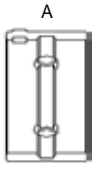
CIL.	AÑO	MOTOR / APLICACIÓN		Diámetro del Cilindro		Carrera	COJINETE, BUJE O ARANDELA	No. de Parte	Ubicación	
				Nominal	Bore					
CYL.	YEAR	ENGINE / APPLICATION		mm	Pulgadas	mm	Pulgadas	BEARING, BUSHING OR THURST WASHER	Part Number	Location
										
1	L4									
	2000-05	G4HC (1.0L) (999cc) Atos, Atos Prime		66.00 2.598		73.00 2.874				
	2004-08	1086cc (1.1L) SOHC 12V (1086 cc) Atos, Atos Prime		67.00 2.638		77.00 3.031				
							COJINETE DE BIELA	4B7000 STD 25MM 50MM		TODOS
							COJINETE DE BANCADA	5C7000 STD 25MM		1-2-3-4-5 (A, B) 3 (C)

Diámetro Estándar del Muñón Standard Shaft Diameter	Diámetro Total del Alojamiento Housing Bore	Ancho del Cojinete Width Bearing	Espesor Máximo de Pared Max Wall Thickness	Claro de Lubricación Oil Clearance	Torque Torque	Imagen del Cojinete / Arandela Image of the Bearing and Thrust Washer
						
37.986/38.001 1.496/1.496	40.965/40.991 1.613/1.614	14.61 0.575	1.499 0.0590	0.0177/0.0355 0.0007/0.0014	Paso 1 14 a 16 N.m 10 a 12 Lbs.Ft Paso 2 27 a 31 N.m 20 a 23 Lbs.Ft	 8 Piezas
41.966/41.994 1.652/1.653	45.987/46.012 1.811/1.812	16.13 0.635	1.981 0.0780	0.0127/0.0406 0.0005/0.0016	Paso 1 34 a 38 N.m 25 a 28 Lbs.Ft Paso 2 68 a 75 N.m 50 a 55 Lbs.Ft	 A 5 Pzas.  B 5 Pzas.  C 2 Pzas.

ISUZU

MORESA

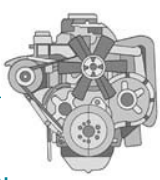
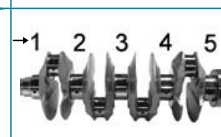
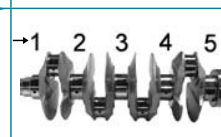
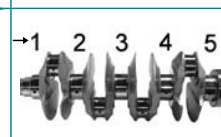

4 CILINDROS / 4 CYLINDER		
MOTOR / ENGINE	AÑO / YEAR	LINEA / LINE
G180 (1.8L) SOHC 8 valve	1969-87	1
4FB1, 4FB1-T (1.8L)	1979-86	1
4ZC1 (2.0L) SOHC Turbo	1985-89	2
G200 (2.0L)	1988-89	3
G200 (2.0L) SOHC 8 valve	1988-89	3
4ZD1 (2.2L) SOHC 8 valve	1986-95	2

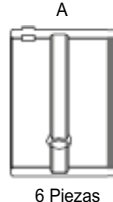
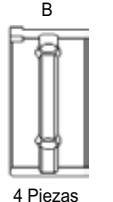
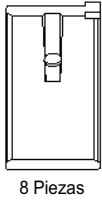
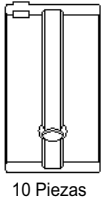
CIL.	AÑO	MOTOR / APLICACIÓN		Diámetro del Cilindro Nominal Bore	Carrera Stroke	COJINETE, BUJE O ARANDELA	No. de Parte		Ubicación Location
				mm Pulgadas	mm Pulgadas				
1	L4	1969-87	G180 (1.8L) SOHC 8 valve (1817 cc) I-Mark (RWD), Pick-up	84.00 3.307	82.00 3.228	COJINETE DE BANCADA 1969-87 G180 SOHC 8 Válvulas	5C1298 STD 010 020 030		1-3-5 (A)
		1979-86	4FB1, 4FB1-T (1.8L) (1817 cc) Gemini, Fargo, I-Mark Diesel (RWD)	84.00 3.307	82.00 3.228				2-4 (B)
						ARANDELA 1979-86 4FB1, 4FB1-T	AM451 STD		3
2	L4	1985-89	4ZC1 (2.0L) SOHC Turbo (1994 cc)	82.00 3.228	84.00 3.307	COJINETE DE BIELA	4B1377 STD 010 020 030		TODOS
		1986-95	4ZD1 (2.2L) SOHC 8 valve (2254 cc)	82.00 3.228	84.00 3.307				
							COJINETE DE BANCADA	5C1775 STD 010 020 030	
						ARANDELA	AM451 STD		3

Diámetro Estándar del Muñón Standard Shaft Diameter	Diámetro Total del Alojamiento Housing Bore	Ancho del Cojinete Width Bearing	Esesor Máximo de Pared Max Wall Thickness	Claro de Lubricación Oil Clearance	Torque	Imagen del Cojinete / Arandela Image of the Bearing and Thrust Washer
mm Pulgadas	mm Pulgadas	mm Pulgadas	mm Pulgadas	mm Pulgadas	N.m Lbs.Ft	
55.921/55.936 2.202/2.202	58.979/58.999 2.322/2.323	32.13 1.265	1.514 0.0596	0.0228/0.0990 0.0009/0.0039	98 N.m 72 Lbs.Ft	 A 6 Piezas
55.921/55.936 2.202/2.202	58.979/58.999 2.322/2.323	21.11 0.831	1.514 0.0596	0.0228/0.0990 0.0009/0.0039		 B 4 Piezas
63.749/64.000 2.510/2.520	80.201/80.449 3.158/3.167		2.360 0.0929			2 Piezas
48.925/48.941 1.926/1.927	51.984/51.999 2.047/2.047	21.51 0.847	1.514 0.0596	0.0304/0.1016 0.0012/0.0040	42 a 46 N.m 31 a 34 Lbs.Ft	 8 Piezas
55.921/55.931 2.202/2.202	0.000/60.000 0.000/2.362	21.87 0.861	2.009 0.0791	0.0330/0.0711 0.0013/0.0028	98 N.m 72 Lbs.Ft	 10 Piezas
63.749/64.000 2.510/2.520	80.201/80.449 3.158/3.167		2.360 0.0929			2 Piezas

ISUZU

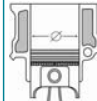
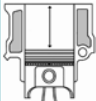
MORESA!

CIL.	AÑO	MOTOR / APLICACIÓN		Diámetro del Cilindro Nominal Bore	Carrera Stroke	COJINETE, BUJE O ARANDELA	No. de Parte	Ubicación Location
CYL.	YEAR	ENGINE / APPLICATION		 mm Pulgadas	 mm Pulgadas	BEARING, BUSHING OR THURST WASHER	Part Number	
L4	1988-89	G200 (2.0L) (1949 cc) Impulse, Pick-up, Trooper II		87.00 3.425	82.00 3.228	COJINETE DE BIELA	4B1377 STD 010 020 030	TODOS
	1988-89	G200 (2.0L) SOHC 8 valve (1949 cc) Impulse, Pick-up, Trooper II		87.00 3.425	82.00 3.228			COJINETE DE BANCADA
						ARANDELA	AM451 STD	

Línea Line

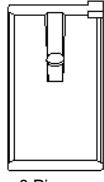
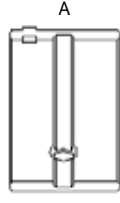
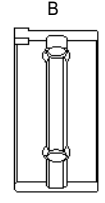

3

Diámetro Estándar del Muñón Standard Shaft Diameter	Diámetro Total del Alojamiento Housing Bore	Ancho del Cojinete Width Bearing	Espesor Máximo de Pared Max Wall Thickness	Claro de Lubricación Oil Clearance	Torque Torque	Imagen del Cojinete / Arandela Image of the Bearing and Thrust Washer
mm Pulgadas	mm Pulgadas	mm Pulgadas	mm Pulgadas	mm Pulgadas	N.m Lbs.Ft	
48.925/48.941 1.926/1.927	51.984/51.999 2.047/2.047	21.51 0.847	1.514 0.0596	0.0304/0.1016 0.0012/0.0040	42 a 46 N.m 31 a 34 Lbs.Ft	 8 Piezas
55.921/55.936 2.202/2.202	58.979/58.999 2.322/2.323	32.13 1.265	1.514 0.0596	0.0228/0.0990 0.0009/0.0039	98 N.m 72 Lbs.Ft	 6 Piezas  4 Piezas
55.921/55.936 2.202/2.202	58.979/58.999 2.322/2.323	21.11 0.831	1.514 0.0596	0.0228/0.0990 0.0009/0.0039		
63.749/64.000 2.510/2.520	80.201/80.449 3.158/3.167		2.360 0.0929			2 Piezas

MAZDA



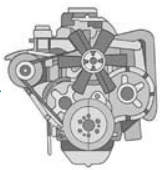

MORESA!

4 CILINDROS / 4 CYLINDER		
MOTOR / ENGINE	AÑO / YEAR	LINEA / LINE
TC (1.3L) SOHC	1978	1
UC (1.4L) SOHC	1979-80	1
E5 (1.5L) SOHC	1981-85	1
UB (1.5L)	1970-73	2
NA (1.6L) SOHC 8 valve	1970-77	2
VC (1.8L)	1973-86	2
VB (1.8L) SOHC 8 valve	1968-78	3
MA (2.0L) SOHC 8 valve	1977-89	3

CIL.	AÑO	MOTOR / APLICACIÓN		Diámetro del Cilindro Nominal Bore	Carrera Stroke	COJINETE, BUJE O ARANDELA	No. de Parte		Ubicación Location
				mm Pulgadas	mm Pulgadas				
1	L4	1978	TC (1.3L) SOHC (1272 cc) 808,1300,Familia	73.00 2.874	76.00 2.992	COJINETE DE BIELA	4B1279 STD 010 020 030	TODOS	
		1979-80	UC (1.4L) SOHC (1415 cc) GLC	76.99 3.031	76.00 2.992				
	1981-85	E5 (1.5L) SOHC (1490 cc) Familia,GLC	76.99 3.031	80.01 3.151	COJINETE DE BANCADA	5C1560 STD 010 020 030	1-2-3-4-5		
					ARANDELA 1976-90 UC SOHC	AM370 STD	5		
2	L4	1970-73	UB (1.5L) (1490 cc) Luce, Bongo, Cosmo	78.00 3.071	78.00 3.071	COJINETE DE BIELA	4B1250 STD 010 020	TODOS	
		1970-77	NA (1.6L) SOHC 8 valve (1586 cc) 616, 808, B1600, Familia, Bongo	78.00 3.071	83.06 3.270				
		1973-86	VC (1.8L) (1769 cc) Luce, Bongo, Cosmo	80.00 3.150	88.01 3.465	COJINETE DE BANCADA	5C1427 STD 010 020 030	1-2-4 (A) 3-5 (B, C)	
						ARANDELA	AM231 STD	5	

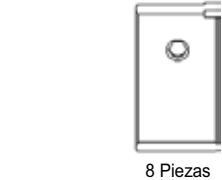
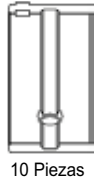

4 CILINDROS / 4 CYLINDER

MOTOR / ENGINE	AÑO / YEAR	LINEA / LINE
FE (2.0L) SOHC 8 valve	1982-87	4
FE (2.0L) Turbo SOHC 8 valve	1986-87	4
FEH1, FEH5 (2.0L)	1983-87	4
F2 (2.2L) SOHC 8 valve	1987-93	4
F2 (2.2L) SOHC 12 valve	1987-93	4
F2 (2.2L) Turbo SOHC 12 valve	1988-92	4
140 Ford SOHC 8 valve	1994-97	5
153 Ford SOHC 8 valve	1998-01	5

Díámetro Estándar del Muñón Standard Shaft Diameter	Díámetro Total del Alojamiento Housing Bore	Ancho del Cojinete Width Bearing	Espesor Máximo de Pared Max Wall Thickness	Claro de Lubricación Oil Clearance	Torque Torque	Imagen del Cojinete / Arandela Image of the Bearing and Thrust Washer
mm Pulgadas	mm Pulgadas	mm Pulgadas	mm Pulgadas	mm Pulgadas	N.m Lbs.Ft	
39.939/39.954 1.572/1.573	43.000/43.015 1.693/1.694	16.99 0.669	1.509 0.0594	0.0254/0.0787 0.0010/0.0031	30 a 34 N.m 22 a 25 Lbs.Ft	 8 Piezas
49.939/49.954 1.966/1.967	54.000/54.013 2.126/2.127	19.13 0.753	2.014 0.0793	0.0254/0.0787 0.0010/0.0031	65 a 69 N.m 48 a 51 Lbs.Ft	 10 Piezas
56.769/57.020 2.235/2.245	68.750/68.999 2.707/2.717		1.999 0.0787			4 Piezas
52.941/52.934 2.084/2.084	56.004/56.020 2.205/2.206	20.93 0.824	1.511 0.0595	0.0431/0.0990 0.0017/0.0039	41 N.m 30 Lbs.Ft 1970 - 74 42 N.m 31 Lbs.Ft 1975 - 88	 8 Piezas
62.939/62.954 2.478/2.479	67.000/67.020 2.638/2.639	18.39 0.724	2.009 0.0791	0.0254/0.0863 0.0010/0.0034	81 N.m 60 Lbs.Ft VB SOHC 85 N.m 63 Lbs.Ft MA SOHC	 6 Piezas
62.939/62.954 2.478/2.479	67.000/67.020 2.638/2.639	24.10 0.949	2.009 0.0791	0.0254/0.0863 0.0010/0.0034		 2 Piezas
62.939/62.954 2.478/2.479	67.000/67.020 2.638/2.639					 2 Piezas
71.501/ 71.750 2.815/ 2.825	86.401/ 86.650 3.402/ 3.411		2.050 0.0807			4 Piezas

MAZDA

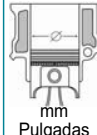
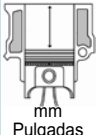
MORESA!

CIL.	AÑO	MOTOR / APLICACIÓN		Diámetro del Cilindro Nominal Bore	Carrera Stroke	COJINETE, BUJE O ARANDELA	No. de Parte	Ubicación Location
				 mm Pulgadas	 mm Pulgadas			
L4	1968-78	VB (1.8L) SOHC 8 valve (1796 cc) 618, B1800, Luce, Pick up		78.00 3.071	94.01 3.701	COJINETE DE BIELA	4B1110 STD 010 020 030	TODOS
	1977-89	MA (2.0L) SOHC 8 valve (1970 cc) 626, B2000, Luce, Pick up		80.01 3.150	97.99 3.858			
								3-5 (B, C)
							ARANDELA	AM231 STD
L4	1982-87	FE (2.0L) SOHC 8 valve (1998 cc) 626, B2000, Bongo, Capella, MPV, Protege		86.11 3.390	86.11 3.390	COJINETE DE BIELA	4B1362 STD 010 020 030 040	TODOS
	1986-87	FE (2.0L) Turbo SOHC 8 valve (1998 cc) 626		86.11 3.390	86.11 3.390			
	1983-87	FEH1, FEH5 (2.0L) (1998 cc) 626 Turbo, B2000		86.11 3.390	86.11 3.390	3 (B, C)		
	1987-93	F2 (2.2L) SOHC 8 valve (2184 cc) B2200, Capella		86.11 3.390	93.98 3.700			
	1987-93	F2 (2.2L) SOHC 12 valve (2184 cc) 626, MX6		86.11 3.390	93.98 3.700			
	1988-92	F2 (2.2L) Turbo SOHC 12 valve (2184 cc) 626, MX6		86.11 3.390	93.98 3.700			

Línea
Line



3

4



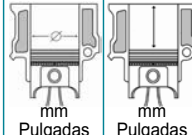
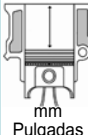

Diámetro Estándar del Muñón Standard Shaft Diameter	Diámetro Total del Alojamiento Housing Bore	Ancho del Cojinete Width Bearing	Espesor Máximo de Pared Max Wall Thickness	Claro de Lubricación Oil Clearance	Torque Torque	Imagen del Cojinete / Arandela Image of the Bearing and Thrust Washer
52.941/52.954 2.084/2.085	55.999/56.020 2.205/2.206	22.00 0.866	1.510 0.0594	0.0355/0.0914 0.0014/0.0036	41 N.m 31 Lbs.Ft	 8 Piezas
62.939/62.954 2.478/2.479	67.000/67.020 2.638/2.639	18.39 0.724	2.009 0.0791	0.0254/0.0863 0.0010/0.0034	81 N.m 60 Lbs.Ft VB SOHC	 6 Piezas 2 Piezas 2 Piezas
62.939/62.954 2.478/2.479	67.000/67.020 2.638/2.639	24.10 0.949	2.009 0.0791	0.0254/0.0863 0.0010/0.0034	85 N.m 63 Lbs.Ft MA SOHC	 6 Piezas 2 Piezas 2 Piezas
71.501/71.750 2.815/2.825	86.401/86.650 3.402/3.411		2.050 0.0807			 2 Piezas
50.940/50.950 2.006/2.006	53.998/54.018 2.126/2.127	21.13 0.832	1.509 0.0594	0.0304/0.0660 0.0012/0.0026	50 a 56 N.m 37 a 41 Lbs.Ft B2000 65 a 69 N.m 48 a 51 Lbs.Ft B2200	 8 Piezas
59.938/59.700 2.360/2.350	63.997/64.018 2.519/2.520	19.13 0.753	2.014 0.0793	0.0177/0.0762 0.0007/0.0030	83 a 92 N.m 61 a 68 Lbs.Ft B2000	 8 Piezas 1 Pieza 1 Pieza
59.938/59.700 2.360/2.350	63.997/64.018 2.519/2.520	27.99 1.102	2.014 0.0793	0.0177/0.0762 0.0007/0.0030	83 a 88 N.m 61 a 65 Lbs.Ft B2200	 8 Piezas 1 Pieza 1 Pieza

MAZDA

MORESA

CIL.	AÑO	MOTOR / APLICACIÓN		Diámetro del Cilindro Nominal Bore	Carrera Stroke	COJINETE, BUJE O ARANDELA	No. de Parte	Ubicación Location
CYL.	YEAR	ENGINE / APPLICATION		 mm Pulgadas	 mm Pulgadas	BEARING, BUSHING OR THURST WASHER	Part Number	
L4	1994-97	140 Ford SOHC 8 valve (2295 cc) B2300		96.01 3.783	79.40 3.126	COJINETE DE BIELA	4B984 STD 010 020 030	→ 1 2 3 4 5 TODOS
	1998-01	153 Ford SOHC 8 valve (2492 cc) B2500		96.01 3.783	86.41 3.402			
						BUJE DE ARBOL 1983-88	MO1443M STD 010	3 (B, C)
								BUJE DE ARBOL 1983-88 Con ranura de lubricación en diametro exterior
						BUJE DE FLECHA AUXILIAR 1983-88	MO1460M STD	



Línea Line
5

Diámetro Estándar del Muñón Standard Shaft Diameter	Diámetro Total del Alojamiento Housing Bore	Ancho del Cojinete Width Bearing	Espesor Máximo de Pared Max Wall Thickness	Claro de Lubricación Oil Clearance	Torque Torque	Imagen del Cojinete / Arandela Image of the Bearing and Thrust Washer
mm Pulgadas	mm Pulgadas	mm Pulgadas	mm Pulgadas	mm Pulgadas	N.m Lbs.Ft	
51.981/51.999 2.047/2.047	55.169/55.189 2.172/2.173	20.32 0.800	1.585 0.0624	0.0127/0.0762 0.0005/0.0030	41 a 49 N.m 30 a 36 Lbs.Ft	 8 Piezas
56.010/56.030 2.205/2.206	60.886/60.907 2.397/2.398	24.13 0.950	2.428 0.0956	0.0203/0.0660 0.0008/0.0026	109 a 122 N.m	 4 Piezas
56.010/56.030 2.205/2.206	60.886/60.907 2.397/2.398	30.35 1.195	2.428 0.0956	0.0203/0.0660 0.0008/0.0026	80 a 90 Lbs.Ft	 5 Piezas
						 1 Pieza
44.991/45.009 1.771/ 1.772	48.275/48.301 1.901/1.902	17.48 0.688	1.621 0.0638	0.0254/0.1219 0.0010/0.0048		4 Piezas
44.991/45.009 1.771/1.772	48.275/48.301 1.901/1.902	17.48 0.688	1.621 0.0638	0.0254/0.1219 0.0010/0.0048		4 Piezas
41.961/41.986 1.652/1.653	45.644/45.669 1.797/1.798	12.83 0.505	1.814 0.0714	0.0177/0.1193 0.0007/0.0047		1 Pieza
41.961/41.986 1.652/1.653	45.136/45.161 1.777/1.778	12.83 0.505	1.560 0.0614	0.0177/0.1193 0.0007/0.0047		1 Pieza

MITSUBISHI

MORESA!

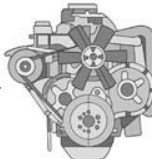
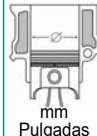
4 CILINDROS / 4 CYLINDER		
MOTOR / ENGINE	AÑO / YEAR	LINEA / LINE
G11B, 4G11 (1.3L)	1977-85	1
G13B, 4G13 (1.3L)	1983-	1
G12B, 4G12 (1.4L)	1976-88	1
G15B, 4G15, G4AJ (1.5L) SOHC 8 valve	1983-90	1
4G15 (1.5L) SOHC 12 valve	1991-02	1
G4AJ (1.5L) 8 valve	1987-89	1
G15B, 4G15, G4AJ (1.5L) SOHC 8 valve	1989-90	2
4G15 (1.5L) SOHC 12 valve	1991-02	2
G4DJ (1.5L) 8 valve	1990-94	3
4G61 (1.6L) DOHC 16 valve	1991-92	3
4G61T (1.6L) Turbo DOHC 16 valve	1989-90	3
G32B (1.6L) Turbo SOHC 12 valve	1985-88	3
G32B, (1.6L) 4G32		3
4G37 (1.8L) SOHC 8 valve	1989-94	3
4G63 (2.0L) SOHC 8 valve	1989-92	4
4G63 (2.0L) DOHC 16 valve	1989-94	4
4G63T (2.0L) Turbo DOHC 16 valve	1989-94	4

CIL.	AÑO	MOTOR / APLICACIÓN		Diámetro del Cilindro	Carrera	COJINETE, BUJE O ARANDELA	No. de Parte	Ubicación
				Nominal Bore	Stroke			
CYL.	YEAR	ENGINE / APPLICATION		mm Pulgadas	mm Pulgadas	BEARING, BUSHING OR THURST WASHER	Part Number	→ 1 2 3 4 5
L4	1977-85	G11B, 4G11 (1.3L) (1244 cc) Lancer, Mirage		69.50 2.736	82.04 3.230	COJINETE DE BIELA	4B1278 STD 010 020 030 040	 TODOS
	1983	G13B, 4G13 (1.3L) (1298 cc) Lancer, Mirage		71.00 2.795	82.04 3.230			
	1976-88	G12B, 4G12 (1.4L) (1410 cc) Lancer, Mirage		74.00 2.913	82.04 3.230			
	1983-90	G15B, 4G15, G4AJ (1.5L) SOHC 8 valve (1468 cc) Lancer, Mirage		75.48 2.972	82.04 3.230	COJINETE DE BANCADA	5C1668 STD 010 020 030	1-2-4-5 (A, B)
	1991-02	4G15 (1.5L) SOHC 12 valve (1468 cc) Mirage		75.48 2.972	82.04 3.230			3 (C)
	1987-89	G4AJ (1.5L) 8 valve (1468 cc)		75.48 2.972	82.04 3.230			

Línea Line





1

4 CILINDROS / 4 CYLINDER

MOTOR / ENGINE	AÑO / YEAR	LINEA / LINE
G64B, 4G64 (2.4L)	1985-00	4
G64B (2.4L) SOHC 12 valve	1985-88	4
4G64 (2.4L) SOHC 8 valve	1989-96	4
4G64 (2.4L) SOHC 16 valve	1993-05	4
4G64 (2.4L) DOHC 16 valve	1994	4
4G54 (2.6L)	1983-89	5
G54B, 4G54 (2.6L) SOHC 12 valve	1983-89	5
G54B (2.6L) Turbo SOHC 12 valve	1983-89	5

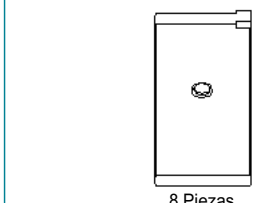
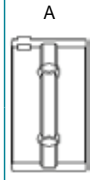

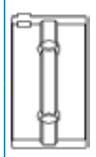

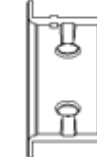
6 CILINDROS / 6 CYLINDER

MOTOR / ENGINE	AÑO / YEAR	LINEA / LINE
6G72 (3.0L)	1986-92	6
6G72 (3.0L) SOHC 12 valve	1988-99	6
6G72 (3.0L) SOHC 24 valve	1994-05	6
6G72 (3.0L) DOHC 24 valve	1991-99	6
6G72T (3.0L) Turbo DOHC 24 valve	1991-99	6

Diámetro Estándar del Muñón Standard Shaft Diameter	Diámetro Total del Alojamiento Housing Bore	Ancho del Cojinete Width Bearing	Espesor Máximo de Pared Max Wall Thickness	Claro de Lubricación Oil Clearance	Torque Torque	Imagen del Cojinete / Arandela Image of the Bearing and Thrust Washer
mm Pulgadas	mm Pulgadas	mm Pulgadas	mm Pulgadas	mm Pulgadas	N.m Lbs.Ft	
41.979/41.999 1.653/1.654	45.001/45.022 1.772/1.773	17.63 0.694	1.494 0.0588	0.0279/0.0889 0.0011/0.0035	33 a 34 N.m 24 a 25 Lbs.Ft	 8 Piezas
47.981/48.001 1.889/1.890	51.999/52.019 2.047/2.048	19.13 0.753	1.989 0.0783	0.0279/0.0863 0.0011/0.0034	50 a 53 N.m	A  B  C 
47.981/ 48.001 1.889/1.890	51.999/52.019 2.047/2.048	23.95 0.943	1.989 0.0783	0.0279/0.0863 0.0011/0.0034	37 a 39 Lbs.Ft	4 Piezas  4 Piezas  2 Piezas 

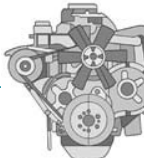



MITSUBISHI

MORESA!

CIL.	AÑO	MOTOR / APLICACIÓN		Diámetro del Cilindro Nominal Bore	Carrera Stroke	COJINETE, BUJE O ARANDELA	No. de Parte	Ubicación Location
CYL.	YEAR	ENGINE / APPLICATION		 mm Pulgadas	 mm Pulgadas	BEARING, BUSHING OR THURST WASHER	Part Number	
2	L4							
	1989-90	G15B, 4G15, G4AJ (1.5L) SOHC 8 valve (1468 cc) Lancer, Mirage	75.44 2.970	81.99 3.228	COJINETE DE BIELA	5C1668 STD 010 020 030	1-2-4-5 (A, B)	
	1991-02	4G15 (1.5L) SOHC 12 valve (1468 cc) Mirage	75.44 2.970	81.99 3.228				
1990-94	G4DJ (1.5L) 8 valve (1468 cc)	75.44 2.970	81.99 3.228	3 (C)				
3	L4							
	1991-92	4G61 (1.6L) DOHC 16 valve (1595 cc) Mirage	82.30 3.240	74.93 2.950	COJINETE DE BIELA	4B1120 STD 010 020 030	TODOS	
	1989-90	4G61T (1.6L) Turbo DOHC 16 valve (1595 cc) Mirage	82.30 3.240	74.93 2.950				
	1985-88	G32B (1.6L) Turbo SOHC 12 valve (1597 cc) Mirage	76.90 3.028	85.85 3.380				
		G32B, (1.6L) 4G32 (1597 cc) Lancer, Mirage, Galant, Delicia	76.90 3.028	85.85 3.380	COJINETE DE BANCADA	5C1559 STD 010 020 030 040	1-2-4-5 (A, B)	
1989-94	4G37 (1.8L) SOHC 8 valve (1755 cc) Eclipse	80.60 3.173	85.85 3.380	3 (C)				

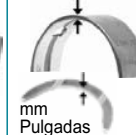
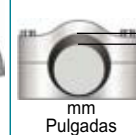

MORESA

MITSUBISHI

Diámetro Estándar del Muñón Standard Shaft Diameter	Diámetro Total del Alojamiento Housing Bore	Ancho del Cojinete Width Bearing	Espesor Máximo de Pared Max Wall Thickness	Claro de Lubricación Oil Clearance	Torque Torque	Imagen del Cojinete / Arandela Image of the Bearing and Thrust Washer
						
47.981/48.001 1.889/1.890	51.999/52.019 2.047/2.048	19.13 0.753	1.989 0.0783	0.027970.0863 0.0011/0.0034	50 a 53 N.m 37 a 39 Lbs.Ft	A B C 4 Piezas 4 Piezas 2 Piezas
47.981/48.001 1.889/1.890	51.999/52.019 2.047/2.048	23.95 0.943	1.989 0.0783	0.027970.0863 0.0011/0.0034		
44.981/45.001 1.771/1.772	48.003/48.016 1.890/1.890	23.60 0.929	1.494 0.0588	0.0152/0.0762 0.0006/0.0030	31 a 34 N.m 23 a 25 Lbs.Ft	8 Piezas
56.985/57.000 2.244/2.244	61.001/61.021 2.402/2.402	23.09 0.909	1.991 0.0784	0.0203/0.0812 0.0008/0.0032	49 a 53 N.m	A B C 4 Piezas 4 Piezas 2 Piezas
56.985/57.000 2.244/2.244	61.001/61.021 2.402/2.402	28.96 1.140	1.991 0.0784	0.0203/0.0812 0.0008/0.0032	36 a 39 Lbs.Ft	

MITSUBISHI

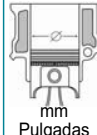
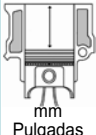
MORESA!





CIL.	AÑO	MOTOR / APLICACIÓN		Diámetro del Cilindro Nominal Bore	Carrera Stroke	COJINETE, BUJE O ARANDELA	No. de Parte	Ubicación Location
CYL.	YEAR	ENGINE / APPLICATION		 mm Pulgadas	 mm Pulgadas	BEARING, BUSHING OR THURST WASHER	Part Number	
L4	1989-92	4G63 (2.0L) SOHC 8 valve (1997 cc) Galant	85.00 3.346	88.00 3.465	COJINETE DE BIELA	4B1120 STD 010 020 030	→ 1 2 3 4 5 TODOS	
	1989-94	4G63 (2.0L) DOHC 16 valve (1996 cc) Eclipse, Galant	85.00 3.346	88.00 3.465				
	1989-94	4G63T (2.0L) Turbo DOHC 16 valve (1997 cc) Eclipse, Galant	85.00 3.346	88.00 3.465	COJINETE DE BANCADA	5C1559 STD 010 020 030 040	1-2-4-5 (A, B)	
	1985-00	G64B, 4G64 (2.4L) (2350 cc) Galant, Delicia	86.50 3.406	100.00 3.937				
	1985-88	G64B (2.4L) SOHC 12 valve (2350 cc) Galant, Van, Wagon	86.50 3.406	100.00 3.937				
	1989-96	4G64 (2.4L) SOHC 8 valve (2350 cc) Expo, Mighty Max, Pick-up, Van, Wagon	86.50 3.406	100.00 3.937	BUJE DE ARBOL	MO1810M STD	3 (C)	
	1993-05	4G64 (2.4L) SOHC 16 valve (2350 cc) Eclipse, Expo, Galant, Montero Sport, Outlander	86.50 3.406	100.00 3.937				
	1994	4G64 (2.4L) DOHC 16 valve (2350 cc) Galant	86.50 3.406	100.00 3.937			1	
							2-3	

Línea Line

4

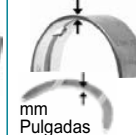
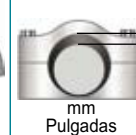

MORESA

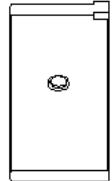
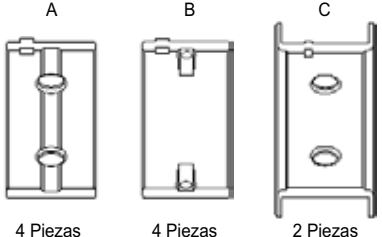



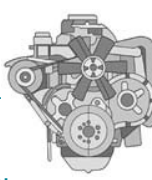
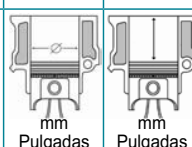
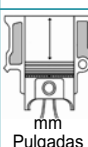

MITSUBISHI

Diámetro Estándar del Muñón Standard Shaft Diameter	Diámetro Total del Alojamiento Housing Bore	Ancho del Cojinete Width Bearing	Espesor Máximo de Pared Max Wall Thickness	Claro de Lubricación Oil Clearance	Torque Torque	Imagen del Cojinete / Arandela Image of the Bearing and Thrust Washer
 mm Pulgadas	 mm Pulgadas	 mm Pulgadas	 mm Pulgadas	 mm Pulgadas	 N.m Lbs.Ft	
44.981/45.001 1.771/1.772	48.003/48.016 1.890/1.890	23.60 0.929	1.494 0.0588	0.0152/0.0762 0.0006/0.0030	31 a 34 N.m 23 a 25 Lbs.Ft	 8 Piezas
56.985/57.000 2.244/2.244	61.001/61.021 2.402/2.402	23.09 0.909	1.991 0.0784	0.0203/0.0812 0.0008/0.0032	49 a 53 N.m	
56.985/57.000 2.244/2.244	61.001/61.021 2.402/2.402	28.96 1.140	1.991 0.0784	0.0203/0.0812 0.0008/0.0032	36 a 39 Lbs.Ft	4 Piezas 4 Piezas 2 Piezas
41.9760 1.6526	45.0240 1.7726	19.00 0.748	1.506 0.0593	0.0254/0.0787 0.0010/0.0031		1 Pieza
40.9676 1.6129	44.0258 1.7333	21.00 0.8268	1.496 0.0589	0.0254/0.0787 0.0010/0.0031		2 Piezas

MITSUBISHI

MORESA!

CIL.	AÑO	MOTOR / APLICACIÓN		Diámetro del Cilindro Nominal Bore	Carrera Stroke	COJINETE, BUJE O ARANDELA	No. de Parte	Ubicación Location
CYL.	YEAR	ENGINE / APPLICATION		 mm Pulgadas	 mm Pulgadas	BEARING, BUSHING OR THURST WASHER	Part Number	
5	L4	1983-89 4G54 (2.6L) (2555 cc) Galant	91.19 3.590	98.04 3.860	COJINETE DE BIELA	4B1220 STD 010 020 030 040	TODOS	
		1983-89 G54B, 4G54 (2.6L) SOHC 12 valve (2555 cc) 2600, Galant, Jeep, Mighty Max, Montero, Pick-up, SPX	91.19 3.590	98.04 3.860	COJINETE DE BANCADA 1972-78 G52B, 4G52 1973-78 4G53 1978-89	5C1945 STD 010 020 030	1-2-4-5 (A, B)	
		1983-89 G54B (2.6L) Turbo SOHC 12 valve (2555 cc) Starion	91.19 3.590	98.04 3.860	G54B, 4G54 SOHC 12 valve 1983-89 G54B Turbo SOHC 12 valve		3 (C)	
					BUJE DE FLECHA AUXILIAR 1972-78 G52B, 4G52 1973-78 4G53 1978-89 G54B, 4G54 SOHC 12 valve 1983-89 G54B Turbo SOHC 12 valve	MO1805M STD	1-2 3	
6	V6	1986-92 6G72 (3.0L) (2972 cc) Delica, Galant, Pajero	91.00 3.583	76.00 2.992	COJINETE DE BIELA	6B1411 STD 010 020 030	TODOS	
		1988-99 6G72 (3.0L) SOHC 12 valve (2972 cc) 3000GT, Diamante, Galant, Mighty Max, Montero, Pick-up, Sigma	91.00 3.583	76.00 2.992				
		1994-05 6G72 (3.0L) SOHC 24 valve (2972 cc) Eclipse, Galant, Montero	91.00 3.583	76.00 2.992	COJINETE DE BANCADA	4C1720 STD 010 020 030	1-2-3-4 (A, B)	
		1991-99 6G72 (3.0L) DOHC 24 valve (2972 cc) 3000GT, Diamante	91.00 3.583	76.00 2.992				
		1991-99 6G72T (3.0L) Turbo DOHC 24 valve (2972 cc) 3000GT	91.00 3.583	76.00 2.992	ARANDELA	AM458 STD	3	



Diámetro Estándar del Muñón Standard Shaft Diameter	Diámetro Total del Alojamiento Housing Bore	Ancho del Cojinete Width Bearing	Esesor Máximo de Pared Max Wall Thickness	Claro de Lubricación Oil Clearance	Torque Torque	Imagen del Cojinete / Arandela Image of the Bearing and Thrust Washer
mm Pulgadas	mm Pulgadas	mm Pulgadas	mm Pulgadas	mm Pulgadas	N.m Lbs.Ft	
52.979/53.000 2.086/2.087	55.999/56.020 2.205/2.206	24.99 0.984	1.499 0.0590	0.0127/0.0711 0.0005/0.0028	45 a 46 N.m 33 a 34 Lbs.Ft	 8 Piezas
59.980/60.000 2.361/2.362	64.000/64.021 2.520/2.521	25.13 0.989	1.991 0.0784	0.0279/0.0939 0.0011/0.0037	75 a 83 N.m	 4 Piezas
59.980/60.000 2.361/2.362	64.000/64.021 2.520/2.521	30.96 1.219	1.991 0.0784	0.0279/0.0939 0.0011/0.0037	55 a 61 Lbs.Ft	 4 Piezas
43.010/43.025 1.693/1.694	46.030/46.050 1.812/1.813	19.99 0.787	1.481 0.0583	0.0279/0.0939 0.0013/0.0037		 2 Piezas
22.9362/22.9793 0.9039/0.9047	25.9994/26.0197 1.0236/1.0244	18.01 0.709	1.506 0.0593	0.0203/0.0863 0.0008/0.0034		1 Pieza
49.972/50.000 1.967/1.969	53.000/53.020 2.087/2.087	15.39 0.606	1.491 0.0587	0.0228/0.0685 0.0009/0.0027	52 N.m 38 Lbs.Ft	 8 Piezas
59.972/60.000 2.361/2.362	64.000/64.021 2.520/2.521	18.01 0.709	1.989 0.0783	0.0177/0.0863 0.0007/0.0034	81 N.m 60 Lbs.Ft	 4 Piezas
65.999/66.251 2.598/2.608	77.699/77.953 3.059/3.069		1.974 0.0777			 4 Piezas



4 CILINDROS / 4 CYLINDER		
MOTOR / ENGINE	AÑO / YEAR	LINEA / LINE
A12 (1.2L)	1970-82	1
A12A (1.2L)	1978-81	1
E1 (1.2L)	1961-66	2
J (1.3L)	1965-69	2
J13 (1.3L)	1969-75	2
A13 (1.3L)	1976-81	1
A13S (1.3L)	1976-81	1
A14 (1.4L)	1974-84	1
J15 (1.4L)	1970-79	2
A15 (1.5L)	1980-91	1
E15, E15S (1.5L) SOHC 8 valve	1981-91	3
E15T (1.5L) Turbo SOHC 8 valve	1983-84	3
J16 (1.6L)	1972-85	2
E16 (1.6L) SOHC 8 valve	1983-86	3
E16I, E16S (1.6L) SOHC 8 valve	1986-88	3
L16 (1.6L)	1967-89	4
GA16DE (1.6L) DOHC 16 valve	1991-99	5
GA16I (1.6L) SOHC 12 valve	1989-90	5
K4M (1.6L)	1999-08	6
J18 (1.8L)	1981-93	7
L18 (1.8L)	1970-81	4
QG18DE (1.8L) DOHC 16 valve	2000-05	8
L20B (2.0L) SOHC 8 valve	1974-80	9
LD20 (2.0L)	1978-91	9
Z20, Z20E, Z20S (2.0L) SOHC 8 valve	1975-86	9
SR20DE (2.0L) DOHC 16 valve	1991-02	10
Z22, Z22E (2.2L) SOHC 8 valve	1982-88	9
Z24, Z24i (2.4L) SOHC 8 valve	1983-89	9
KA24DE (2.4L) DOHC 16 valve	1999-08	11
KA24E (2.4L) SOHC 12 valve	1989-98	11

6 CILINDROS / 6 CYLINDER		
MOTOR / ENGINE	AÑO / YEAR	LINEA / LINE
L24 (2.4L)	1971-87	12
L26 (2.6L)	1971-78	12
L28 (2.8L)	1975-83	12
LD28 (2.8L)	1979-86	12
VG30 (3.0L)	1983-	13
VG30D (3.0L)	1987-	13
VG30 (3.0L) SOHC 12 valve	1984-89	13
VG30E, VG30i (3.0L) SOHC 12 valve	1984-98	13
VG30T (3.0L) Turbo SOHC 12 valve	1984-98	13
VG30DE (3.0L) DOHC 24 valve	1984-98	13
VG30DETT (3.0L) Twin Turbo DOHC 24 valve	1990-96	13
VG33E (3.3L) SOHC 12 valve	1996-04	13

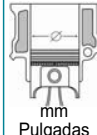
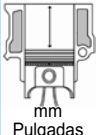
NISSAN

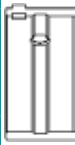

MORESA!

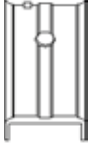
CIL.	AÑO	MOTOR / APLICACIÓN		Diámetro del Cilindro Nominal Bore	Carrera Stroke	COJINETE, BUJE O ARANDELA	No. de Parte	Ubicación Location
CYL.	YEAR	ENGINE / APPLICATION		 mm Pulgadas	 mm Pulgadas	BEARING, BUSHING OR THURST WASHER	Part Number	
1	L4							
	1970-82	A12 (1.2L) (1171 cc) Cherry 1200, Sunny 1200, Datsun	73.00 2.874	70.00 2.756	COJINETE DE BIELA	4B980 STD 010 020 030	1 2 3 4 5	TODOS
	1978-81	A12A (1.2L) (1237 cc) Cherry 210, Pulsar 1200, Sunny 1200, Datsun	75.00 2.953	70.00 2.756				
	1976-81	A13 (1.3L) (1270 cc) B210 1300	76.00 2.992	70.00 2.756	COJINETE DE BANCADA	5C1107 STD 010 020 030	1-5 (A)	
	1976-81	A13S (1.3L) (1270 cc) Sunny 1300, Datsun	76.00 2.992	70.00 2.756			2-4 (B)	
	1974-84	A14 (1.4L) (1397 cc) 140J,210,310,B210,, Auster,Auster Van,Stanza, California 210, Datsun	76.00 2.992	77.00 3.031			3 (C)	
	1980-91	A15 (1.5L) (1487 cc) 210, 310, Sunny, Datsun	76.00 2.992	82.00 3.228	BUJE DE ARBOL	MO1592M STD	1	
				2				
				3				
				4				
							5	

Diámetro Estándar del Muñón Standard Shaft Diameter	Diámetro Total del Alojamiento Housing Bore	Ancho del Cojinete Width Bearing	Espesor Máximo de Pared Max Wall Thickness	Claro de Lubricación Oil Clearance	Torque Torque	Imagen del Cojinete / Arandela Image of the Bearing and Thrust Washer
mm Pulgadas	mm Pulgadas	mm Pulgadas	mm Pulgadas	mm Pulgadas	N.m Lbs.Ft	
44.955/44.968 1.770/1.770	48.001/48.011 1.890/1.890	19.61 0.772	1.504 0.0592	0.0228/0.0609 0.0009/0.0024	31 a 37 N.m 23 a 27 Lbs.Ft	 8 Piezas
49.952/49.964 1.967/1.967	53.645/53.670 2.112/2.113	22.00 0.866	1.834 0.0722	0.0203/0.0812 0.0008/0.0032	49 a 58 N.m 36 a 43 Lbs.Ft	 A  B  C 4 Piezas 4 Piezas 2 Piezas
49.952/49.964 1.967/1.967	53.645/53.670 2.112/2.113	18.01 0.709	1.834 0.0722	0.0203/0.0812 0.0008/0.0032		
49.952/49.964 1.967/1.967	53.645/53.670 2.112/2.113	26.95 1.061	1.834 0.0722	0.0203/0.0812 0.0008/0.0032		
43.7819/43.7946 1.7237/1.7242	47.0001/47.0255 1.8504/1.8514	23.75 0.935	1.584 0.0624	0.0355/0.1143 0.0014/0.0045		1 Pieza
43.2841/43.2968 1.7041/1.7046	46.4997/46.5251 1.8307/1.8317	14.24 0.561	1.584 0.0624	0.0330/0.1117 0.0013/0.0044		1 Pieza
42.7837/42.7964 1.6844/1.6849	45.9994/46.0248 1.8110/1.8120	14.24 0.561	1.584 0.0624	0.0330/0.1117 0.0013/0.0044		1 Pieza
42.2833/42.2960 1.6647/1.6652	45.4990/45.5244 1.7913/1.7923	14.24 0.561	1.584 0.0624	0.0330/0.1117 0.0013/0.0044		1 Pieza
41.2089/41.2216 1.6224/1.6229	44.4246/44.4500 1.7490/1.7500	14.24 0.561	1.584 0.0624	0.0330/0.1117 0.0013/0.0044		1 Pieza

NISSAN

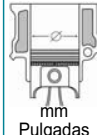
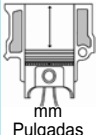
MORESA!

CIL.	AÑO	MOTOR / APLICACIÓN		Diámetro del Cilindro Nominal Bore	Carrera Stroke	COJINETE, BUJE O ARANDELA	No. de Parte	Ubicación Location
CYL.	YEAR	ENGINE / APPLICATION		 mm Pulgadas	 mm Pulgadas	BEARING, BUSHING OR THURST WASHER	Part Number	
L4	1961-66	E1 (1.2L) (1189 cc) Datsun	73.00 2.874	71.00 2.795	COJINETE DE BIELA	4B967 STD 010 020 030 040 050 060	→ 1 2 3 4 5 TODOS	
	1965-69	J (1.3L) (1299 cc) Bluebird, Truck, Datsun	73.00 2.874	77.60 3.055				
	1969-75	J13 (1.3L) (1299 cc) Bluebird, Truck, Datsun	73.00 2.874	77.60 3.055	COJINETE DE BANCADA 1961-69	3C1055 STD 010 020 030	1-2-3	
	1970-79	J15 (1.4L) (1438 cc) Bluebird, Truck, Datsun	78.00 3.071	77.60 3.055				
	1972-85	J16 (1.6L) (1567 cc) Bluebird, Truck, Datsun	78.00 3.071	82.00 3.228				
						COJINETE DE BANCADA 1970-85	3C1329 STD 010 020 030 040 050	1-2-3
						BUJE DE ARBOL	MO1325M STD 010	1
					2			
					3			
					ARANDELA	AM105 STD	2	



Línea Line

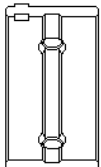
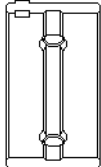





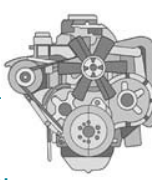
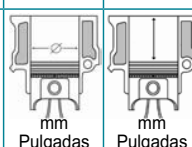
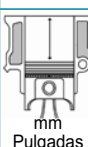





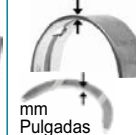
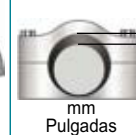

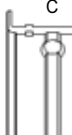

2

Diámetro Estándar del Muñón Standard Shaft Diameter	Diámetro Total del Alojamiento Housing Bore	Ancho del Cojinete Width Bearing	Espesor Máximo de Pared Max Wall Thickness	Claro de Lubricación Oil Clearance	Torque Torque	Imagen del Cojinete / Arandela Image of the Bearing and Thrust Washer
mm Pulgadas	mm Pulgadas	mm Pulgadas	mm Pulgadas	mm Pulgadas	N.m Lbs.Ft	
47.648/47.661 1.876/1.876	51.333/51.346 2.021/2.022	22.10 0.870	1.824 0.0718	0.0228/0.0736 0.0009/0.0029	30 a 34 N.m 22 a 25 Lbs.Ft	 8 Piezas
50.813/50.825 2.001/2.001	54.508/54.521 2.146/2.147	31.12 1.225	1.829 0.0720	0.0127/0.0533 0.0005/0.0021	102 a 109 N.m 75 a 80 Lbs.Ft	 6 Piezas
50.790/50.810 2.000/2.000	54.501/54.521 2.146/2.147	28.19 1.110	1.834 0.0722	0.0203/0.0711 0.0008/0.0028	102 a 109 N.m 75 a 80 Lbs.Ft	 6 Piezas
45.430/45.441 1.789/1.789	48.641/48.666 1.915/1.916	37.08 1.460	1.585 0.0624			1 Pieza
41.219/41.229 1.623/1.623	44.425/44.450 1.749/1.750	20.75 0.817	1.588 0.0625			1 Pieza
43.899/43.909 1.728/1.729	47.117/47.142 1.855/1.856	21.97 0.865	1.585 0.0624			1 Pieza
56.261/56.515 2.215/2.225	69.596/69.850 2.740/2.750		2.337 0.0920			4 Piezas

NISSAN

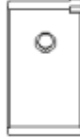
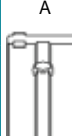

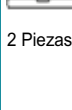
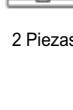
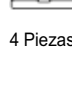
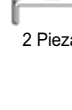

MORESA

CIL.	AÑO	MOTOR / APLICACIÓN		Diámetro del Cilindro Nominal Bore	Carrera Stroke	COJINETE, BUJE O ARANDELA	No. de Parte	Ubicación Location
CYL.	YEAR	ENGINE / APPLICATION		 mm Pulgadas	 mm Pulgadas	BEARING, BUSHING OR THURST WASHER	Part Number	
3	L4							
	1981-91	E15, E15S (1.5L) SOHC 8 valve (1487 cc) 310, Pulsar, Sentra, Tsuru I	76.00 2.992	82.04 3.230	COJINETE DE BIELA Hasta agotar existencias	4B1326 STD 020 030 040	TODOS	
	1983-84	E15T (1.5L) Turbo SOHC 8 valve (1487 cc) Pulsar, Tsuru I	76.00 2.992	82.04 3.230	COJINETE DE BIELA Este producto sustituye al 4B1326	4B1590 STD 010 020 030 040	TODOS	
	1983-86	E16 (1.6L) SOHC 8 valve (1597 cc) Pulsar, Sentra, Tsuru II, Tsuru III	76.00 2.992	88.00 3.465	COJINETE DE BANCADA	5C1595 STD 010 020 030	1-5 (A)	
	1986-88	E16I, E16S (1.6L) SOHC 8 valve (1597 cc) 310, Pulsar, Sentra, , Tsuru II, Tsuru III	76.00 2.992	88.00 3.465			2-4 (B)	
					BUJE DE ARBOL	MO1776M STD	1 2	
4	L4							
	1967-89	L16 (1.6L) (1595 cc) Bluebird, Violet, Stanza	83.00 3.268	73.99 2.913	COJINETE DE BIELA	4B966 STD 010 020 030	TODOS	
	1970-81	L18 (1.8L) (1770 cc) Bluebird, Violet, Stanza	85.00 3.346	78.00 3.071	COJINETE DE BANCADA	5C1054 STD 010 020 030 040	1-5 (A, B)	
				2-4 (C)				
							3 (D)	

Diámetro Estándar del Muñón Standard Shaft Diameter	Diámetro Total del Alojamiento Housing Bore	Ancho del Cojinete Width Bearing	Espesor Máximo de Pared Max Wall Thickness	Claro de Lubricación Oil Clearance	Torque Torque	Imagen del Cojinete / Arandela Image of the Bearing and Thrust Washer
						
mm Pulgadas	mm Pulgadas	mm Pulgadas	mm Pulgadas	mm Pulgadas	N.m Lbs.Ft	
39.954/39.975 1.573/1.574	43.000/43.012 1.693/1.693	16.99 0.669	1.501 0.0591	0.0203/0.0838 0.0008/0.0033	31 a 37 N.m 23 a 27 Lbs.Ft	 8 Piezas
39.954/39.975 1.573/1.574	43.000/43.012 1.693/1.693	16.99 0.669	1.501 0.0591	0.0101/0.0609 0.0004/0.0024	31 a 37 N.m 23 a 27 Lbs.Ft	 8 Piezas
49.939/49.969 1.966/1.967	53.642/53.668 2.112/2.113	22.12 0.871	1.829 0.0720	0.0177/0.0965 0.0007/0.0038	49 a 58 N.m	 A  B  C
49.939/49.969 1.966/1.967	53.642/53.668 2.112/2.113	18.11 0.713	1.829 0.0720	0.0177/0.0965 0.0007/0.0038	36 a 43 Lbs.Ft	 4 Piezas  4 Piezas  2 Piezas
49.939/49.969 1.966/1.967	53.642/53.668 2.112/2.113	26.95 1.061	1.829 0.0720	0.0177/0.0965 0.0007/0.0038		
32.001/31.988 1.2599/1.2594	34.980/35.001 1.3772/1.3780	21.336 0.840	1.483 0.0584	0.0152/0.0533 0.0006/0.0021		
28.602/28.587 1.1261/1.1255	31.625/31.602 1.2451/1.2442	16.129 0.635	1.483 0.0584	0.0152/0.0533 0.0006/0.0021		
49.962/49.975 1.967/1.968	53.000/53.012 2.087/2.087	22.00 0.866	1.504 0.0592	0.0152/0.0660 0.0006/0.0026	45 a 54 N.m 33 a 40 Lbs.Ft	 12 Piezas
63.475/63.500 2.499/2.500	68.250/68.275 2.687/2.688	22.07 0.869	2.375 0.0935	0.0304/0.0812 0.0012/0.0032	45 a 54 N.m	 A  B  C  D
54.943/54.953 2.163/2.164	58.659/58.671 2.309/2.310	24.08 0.948	1.836 0.0723	0.0304/0.0812 0.0012/0.0032	33 a 40 Lbs.Ft	 2 Piezas  2 Piezas  4 Piezas  2 Piezas
54.943/54.953 2.163/2.164	58.659/58.671 2.309/2.310	31.98 1.259	1.836 0.0723	0.0304/0.0812 0.0012/0.0032		

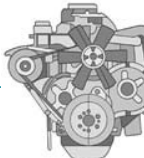
NISSAN

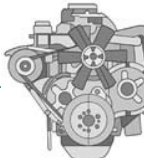
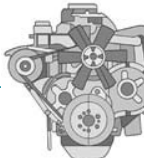

MORESA!

CIL.	AÑO	MOTOR / APLICACIÓN		Diámetro del Cilindro Nominal Bore	Carrera Stroke	COJINETE, BUJE O ARANDELA	No. de Parte	Ubicación Location
CYL.	YEAR	ENGINE / APPLICATION		 mm Pulgadas	 mm Pulgadas	BEARING, BUSHING OR THURST WASHER	Part Number	 → 1 2 3 4 5
L4	1991-99	GA16DE (1.6L) DOHC 16 valve (1597 cc) 200SX, NX 1600, Sentra, Tsuru III, Tsubame		76.00 2.992	88.00 3.465	COJINETE DE BIELA	4B1590 STD 010 020 030 040	TODOS
	1989-90	GA16I (1.6L) SOHC 12 valve (1597 cc) Pulsar, Sentra, Tsuru III, Tsubame		76.00 2.992	88.00 3.465			
							COJINETE DE BANCADA	5C1950 STD 010 020 030 040
L4	1999-08	K4M (1.6L) (1598 cc) Platina, Aprio		79.50 3.130	80.50 3.169	COJINETE DE BIELA	4B7002 STD 010 020	TODOS
						COJINETE DE BANCADA	5C7004 STD 010 020	1-2-3-4-5 (A, B)
						ARANDELA	AM7001 STD	3

Línea Line



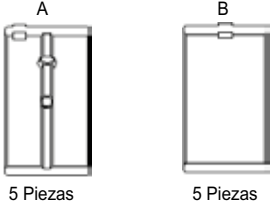

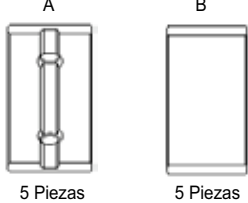
5

6

Diámetro Estándar del Muñón Standard Shaft Diameter	Diámetro Total del Alojamiento Housing Bore	Ancho del Cojinete Width Bearing	Espesor Máximo de Pared Max Wall Thickness	Claro de Lubricación Oil Clearance	Torque Torque	Imagen del Cojinete / Arandela Image of the Bearing and Thrust Washer
mm Pulgadas	mm Pulgadas	mm Pulgadas	mm Pulgadas	mm Pulgadas	N.m Lbs.Ft	
39.954/39.975 1.573/1.574	43.000/43.012 1.693/1.693	16.99 0.669	1.501 0.0591	0.0101/0.0609 0.0004/0.0024	31 a 37 N.m 23 a 27 Lbs.Ft	 8 Piezas
49.939/49.964 1.966/1.967	0.000/53.660 0.000/2.113	17.13 0.674	1.836 0.0723	0.0203/0.0939 0.0008/0.0037	46 a 52 N.m 34 a 38 Lbs.Ft	 5 Piezas 5 Piezas
43.960/43.980 1.731/1.732	47.615/47.625 1.875/1.875	17.75 0.699	1.801 0.0709	0.0203/0.0685 0.0008/0.0027	43 N.m 32 Lbs.Ft	 8 Piezas
47.991/48.011 1.889/1.890	51.935/51.948 2.045/2.045	19.50 0.768	1.951 0.0768	0.0254/0.0762 0.0010/0.0030	24 N.m + 47° 18 Lbs.Ft + 47°	 5 Piezas 5 Piezas
53.500/53.749 2.106/2.116	73.500/74.000 2.894/2.913		2.819 0.1110			2 Piezas

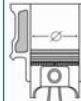
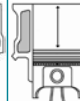
NISSAN



MORESA!

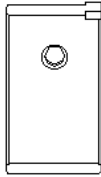
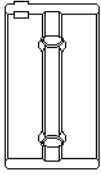
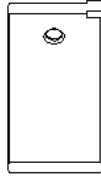





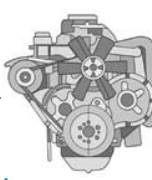
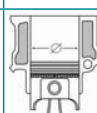
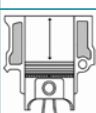

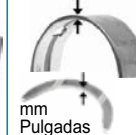
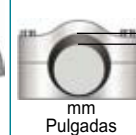

CIL.	AÑO	MOTOR / APLICACIÓN		Diámetro del Cilindro Nominal Bore	Carrera Stroke	COJINETE, BUJE O ARANDELA	No. de Parte	Ubicación Location
CYL.	YEAR	ENGINE / APPLICATION		 mm Pulgadas	 mm Pulgadas	BEARING, BUSHING OR THURST WASHER	Part Number	
7	L4	1981-93 J18 (1.8L) (1751 cc) Bluebird, Truck, Estaquitas		80.50 3.169	86.00 3.386	COJINETE DE BIELA	4BX832 STD 010 020 030	TODOS
						COJINETE DE BANCADA	3C1329 STD 010 020 030 040 050	1-2-3
						BUJE DE ARBOL	MO1325M STD 010	1 2 3
						ARANDELA	AM105 STD	2
8	L4	2000-05 QG18DE (1.8L) DOHC 16 valve (1769 cc) Sentra		80.00 3.150	88.00 3.465	COJINETE DE BIELA	4B1590 STD 010 020 030 040	TODOS

Diámetro Estándar del Muñón Standard Shaft Diameter	Diámetro Total del Alojamiento Housing Bore	Ancho del Cojinete Width Bearing	Espesor Máximo de Pared Max Wall Thickness	Claro de Lubricación Oil Clearance	Torque Torque	Imagen del Cojinete / Arandela Image of the Bearing and Thrust Washer
mm Pulgadas	mm Pulgadas	mm Pulgadas	mm Pulgadas	mm Pulgadas	N.m Lbs.Ft	
47.633/47.645 1.875/1.876	50.673/50.686 1.995/1.996	20.09 0.791	1.501 0.0591	0.0254/0.0660 0.0010/0.0026	27 a 34 N.m 20 a 25 Lbs.Ft	 8 Piezas
50.790/50.810 2.000/2.000	54.501/54.521 2.146/2.147	28.19 1.110	1.834 0.0722	0.0203/0.0711 0.0008/0.0028	102 a 109 N.m 75 a 80 Lbs.Ft	 6 Piezas
45.430/45.441 1.789/1.789	48.641/48.666 1.915/1.916	37.08 1.460	1.585 0.0624			1 Pieza
41.219/41.229 1.623/1.623	44.425/44.450 1.749/1.750	20.75 0.817	1.588 0.0625			1 Pieza
43.899/43.909 1.728/1.729	47.117/47.142 1.855/1.856	21.97 0.865	1.585 0.0624			1 Pieza
56.261/56.515 2.215/2.225	69.596/69.850 2.740/2.750		2.337 0.0920			4 Piezas
39.954/39.975 1.573/1.574	43.000/43.012 1.693/1.693	16.99 0.669	1.501 0.0591	0.0101/0.0609 0.0004/0.0024	31 a 37 N.m 23 a 27 Lbs.Ft	 6 Piezas

NISSAN

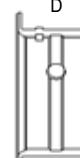

MORESA!

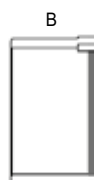
CIL.	AÑO	MOTOR / APLICACIÓN		Diámetro del Cilindro Nominal Bore	Carrera Stroke	COJINETE, BUJE O ARANDELA	No. de Parte	Ubicación Location
CYL.	YEAR	ENGINE / APPLICATION		 mm Pulgadas	 mm Pulgadas	BEARING, BUSHING OR THURST WASHER	Part Number	
9	L4	1974-80	L20B (2.0L) SOHC 8 valve (1952 cc) 200SX, 510, 610, 620, 710, 720, Truck	85.00 3.346	86.00 3.380	COJINETE DE BIELA	4B966 STD 010 020 030	TODOS
	1978-91	LD20 (2.0L) (1952 cc) Laurel, Vanette, Skyline, Bluebird	85.00 3.346	86.00 3.386				
	1975-86	Z20, Z20E, Z20S (2.0L) SOHC 8 valve (1952 cc) 200SX, 510, 720, Silvia, Laurel, Bluebird	85.00 3.346	86.00 3.386	COJINETE DE BANCADA	5C1570 STD 010 020 030 040	1-5 (A, B)	
	1982-88	Z22, Z22E (2.2L) SOHC 8 valve (2187 cc) 200SX, 720, Silvia, Laurel, Bluebird	87.00 3.425	92.00 3.622			2-4 (C)	
	1983-89	Z24, Z24i (2.4L) SOHC 8 valve (2389 cc) 720, D21, Van, Hardbody, Pathfinder	89.00 3.504	96.00 3.780			3 (D)	
10	L4	1991-02	SR20DE (2.0L) DOHC 16 valve (1998 cc) 200SX, Bluebird, Silvia, Primera, Avenir, NX, Sentra, Tsuru 2000	86.00 3.386	86.00 3.386	COJINETE DE BIELA	4B1629 STD 010 020 030	TODOS
						COJINETE DE BANCADA	5C2015 STD 010 020 030	1-2-3-4-5 (A, B)

Diámetro Estándar del Muñón Standard Shaft Diameter	Diámetro Total del Alojamiento Housing Bore	Ancho del Cojinete Width Bearing	Espesor Máximo de Pared Max Wall Thickness	Claro de Lubricación Oil Clearance	Torque Torque	Imagen del Cojinete / Arandela Image of the Bearing and Thrust Washer
						
49.962/49.975 1.967/1.968	53.000/53.012 2.087/2.087	22.00 0.866	1.504 0.0592	0.0152/0.0660 0.0006/0.0026	45 a 54 N.m 33 a 40 Lbs.Ft	 12 Piezas
59.944/59.959 2.360/2.361	63.650/63.668 2.506/2.507	26.16 1.030	1.834 0.0722	0.0177/0.0609 0.0007/0.0024	45 a 54 N.m 33 a 40 Lbs.Ft	 A  B  C  D 2 Piezas 2 Piezas 4 Piezas 2 Piezas
59.944/59.959 2.360/2.361	63.650/63.668 2.506/2.507	24.13 0.950	1.834 0.0722	0.0177/0.0609 0.0007/0.0024		
59.944/59.959 2.360/2.361	63.650/63.668 2.506/2.507	31.98 1.259	1.834 0.0722	0.0177/0.0609 0.0007/0.0024		
47.955/47.973 1.888/1.889	51.001/51.013 2.008/2.008	17.00 0.669	1.496 0.0589	0.0203/0.0457 0.0008/0.0018	Paso 1 14 a 16 N.m 10 a 12 Lbs.Ft Paso 2 38 a 48 N.m 28 a 33 Lbs.Ft	 8 Piezas
54.955/54.981 2.164/2.165	58.943/58.969 2.321/2.322	19.00 0.748	1.976 0.0778	0.0127/0.0558 0.0005/0.0022	Paso 1 33 a 38 N.m 24 a 28 Lbs.Ft Paso 2 73 a 83 N.m 54 a 61 Lbs.Ft	 A  B 5 Piezas 5 Piezas

NISSAN

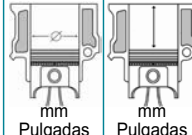
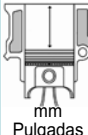

MORESA!

CIL.	AÑO	MOTOR / APLICACIÓN		Diámetro del Cilindro Nominal Bore	Carrera Stroke	COJINETE, BUJE O ARANDELA	No. de Parte	Ubicación Location
CYL.	YEAR	ENGINE / APPLICATION		 mm Pulgadas	 mm Pulgadas	BEARING, BUSHING OR THURST WASHER	Part Number	
11 L4	1999-08	KA24DE (2.4L) DOHC 16 valve (2389 cc) 240SX, Altima, Frontier, Hardbody, Largo, Presage, Xterra, Urvan	89.00 3.504	96.00 3.780	COJINETE DE BIELA	4B1589 STD 010 020 030	TODOS	
	1989-98	KA24E (2.4L) SOHC 12 valve (2389 cc) 240SX, Axxess, D21, Stanza, Estaquitas	89.00 3.504	96.00 3.780				COJINETE DE BANCADA
							3 (C, D)	
12 L6	1971-87	L24 (2.4L) (2393 cc) Maxima, 240Z, 810	83.00 3.268	73.70 2.902	COJINETE DE BIELA	6B966 STD 010 020 030	TODOS	
	1971-78	L26 (2.6L) (2565 cc) 260Z	83.00 3.268	79.00 3.110				COJINETE DE BANCADA
	1975-83	L28 (2.8L) (2753 cc) 280ZX	86.00 3.386	79.00 3.110	COJINETE DE BANCADA	7C1106 STD 010 020 030	2-3-5-6 (C, D)	
	1979-86	LD28 (2.8L) (2792 cc) Maxima Diesel	84.50 3.327	83.00 3.268				

Diámetro Estándar del Muñón Standard Shaft Diameter	Diámetro Total del Alojamiento Housing Bore	Ancho del Cojinete Width Bearing	Espesor Máximo de Pared Max Wall Thickness	Claro de Lubricación Oil Clearance	Torque Torque	Imagen del Cojinete / Arandela Image of the Bearing and Thrust Washer
49.957/49.975 1.967/1.968	52.995/53.012 2.086/2.087	20.12 0.792	1.504 0.0592	0.127/0.0609 0.0004/0.0024	Paso 1 16 N.m 12 Lbs.Ft Paso 2 45 N.m 33 Lbs.Ft 1963- 80	 8 Piezas
59.952/59.974 2.360/2.361	63.665/63.683 2.507/2.507	19.00 0.748	1.834 0.0722	0.0127/0.0965 0.0005/0.0038	52 N.m 38 Lbs.Ft	 4 Piezas 4 Piezas 1 Pieza 1 Pieza
59.952/59.974 2.360/2.361	63.665/63.683 2.507/2.507	26.93 1.060	1.834 0.0722	0.0127/0.0965 0.0005/0.0038		
49.962/49.975 1.967/1.968	53.000/53.012 2.087/2.087	22.00 0.866	1.504 0.0592	0.0152/0.0660 0.0006/0.0026	52 N.m 38 Lbs.Ft	 12 Piezas
54.943/54.955 2.163/2.164	58.661/58.671 2.310/2.310	26.11 1.028	1.834 0.0722	0.0304/0.0812 0.0012/0.0032	45 a 54 N.m 33 a 40 Lbs.Ft L24 50 N.m 37 Lbs.Ft L20 L26 69 a 79 N.m 51 a 58 Lbs.Ft L28	 2 Pzas. 2 Pzas. 4 Pzas. 4 Pzas. 1 Pza. 1 Pza.
54.943/54.955 2.163/2.164	58.661/58.671 2.310/2.310	24.08 0.948	1.834 0.0722	0.0304/0.0812 0.0012/0.0032		
54.943/54.955 2.163/2.164	58.661/58.671 2.310/2.310	31.98 1.259	1.834 0.0722	0.0304/0.0812 0.0012/0.0032		



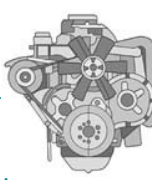
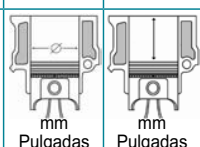



NISSAN

MORESA

CIL.	AÑO	MOTOR / APLICACIÓN			Diámetro del Cilindro Nominal Bore	Carrera Stroke	COJINETE, BUJE O ARANDELA	No. de Parte	Ubicación Location	
CYL.	YEAR	ENGINE / APPLICATION			mm Pulgadas	mm Pulgadas	BEARING, BUSHING OR THURST WASHER	Part Number		
V6	1983-	VG30 (3.0L) (2960 cc) Fairlady Z, Cedric	87.00 3.425	83.00 3.268	COJINETE DE BIELA	6B1591 STD 010 020 030 040	TODOS			
	1987-	VG30D (3.0L) (2960 cc) Fairlady Z, Cedric	87.00 3.425	83.00 3.268						
	1984-89	VG30 (3.0L) SOHC 12 valve (2960 cc) 300ZX, D21	87.00 3.425	83.00 3.268						
	1984-98	VG30E, VG30i (3.0L) SOHC 12 valve (2960 cc) 200SX, D21, Maxima, Pathfinder, 300C, 300SX, Quest	87.00 3.425	83.00 3.268						
	1984-98	VG30T (3.0L) Turbo SOHC 12 valve (2960 cc) 300ZX, Fairlady	87.00 3.425	83.00 3.268						
	1984-98	VG30DE (3.0L) DOHC 24 valve (2960 cc) 300ZX, Maxima	87.00 3.425	83.00 3.268				COJINETE DE BIELA	4C1951 STD 010 020 030	1 (A, B)
	1990-96	VG30DETT (3.0L) Twin Turbo DOHC 24 valve (2960 cc) 300ZX	87.00 3.425	83.00 3.268						2-3 (C, D)
	1996-04	VG33E (3.3L) SOHC 12 valve (3275 cc) Frontier, Pathfinder, Quest, Xterra	91.50 3.602	83.00 3.268						4 (E, F)

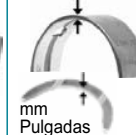
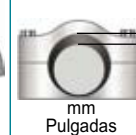
Línea Line

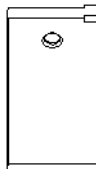
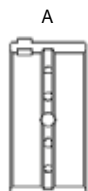
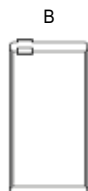
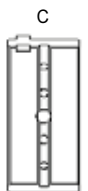

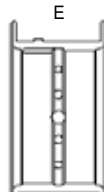
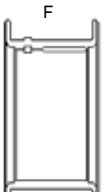
13

Diámetro Estándar del Muñón Standard Shaft Diameter	Diámetro Total del Alojamiento Housing Bore	Ancho del Cojinete Width Bearing	Espesor Máximo de Pared Max Wall Thickness	Claro de Lubricación Oil Clearance	Torque Torque	Imagen del Cojinete / Arandela Image of the Bearing and Thrust Washer
						
49.961/49.987 1.967/1.968	52.984/53.011 2.086/2.087	16.99 0.669	1.509 0.0594	0.0152/0.0609 0.0006/0.0024	45 a 54 N.m 33 a 40 Lbs.Ft 3.0L 3.3L SOHC 58 a 65 N.m 43 a 48 Lbs.Ft 3.0L 3.3L DOHC	 12 Piezas
62.951/62.974 2.478/2.479	66.644/66.672 2.623/2.624	22.50 0.886	1.829 0.0720	0.010170.0863 0.0004/0.0034	91 a 100 N.m 67 a 74 Lbs.Ft	 1 Pz.
62.951/62.974 2.478/2.479	66.644/66.672 2.623/2.624	19.00 0.748	1.829 0.0720	0.010170.0863 0.0004/0.0034		 1 Pz.
62.951/62.974 2.478/2.479	66.644/66.672 2.623/2.624	28.80 1.134	1.829 0.0720	0.010170.0863 0.0004/0.0034		 2 Pzas.
62.951/62.974 2.478/2.479	66.644/66.672 2.623/2.624	28.80 1.134	1.829 0.0720	0.010170.0863 0.0004/0.0034	 2 Pzas.	
						 1 Pz.
						 1 Pz.

RENAULT

MORESA!

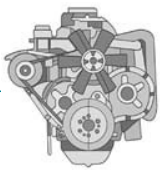
4 CILINDROS / 4 CYLINDER		
MOTOR / ENGINE	AÑO / YEAR	LINEA / LINE
688/689/C1C (1.0L)	1963-66	1
688/.12/.10, 688688.02, 688.01, 688.02/06/10/11, 688.09 (1.1L)	1965-66	1
CIE 715 (1.1L)	1964-69	1
CIE 715 (1.1L)	1964-69	1
CIE,750/G750 (1.1L)	1964-69	1
810/25/26/29/03 (1.3L)	1969-79	1
CIJ,C2J,C3J (1.3L)		1
840-25 (1.3L)		1
C1J,C2J,C3J,847 (1.4L)		1
847 700/701,C1J (1.4L)		1
CIJ 760/764/782 (1.4L) Turbocharged		1

CIL.	AÑO	MOTOR / APLICACIÓN		Diámetro del Cilindro Nominal Bore	Carrera Stroke	COJINETE, BUJE O ARANDELA	No. de Parte		Ubicación Location
				mm Pulgadas	mm Pulgadas				
L4	1963-66	688/689/C1C (1.0L) (956 cc) Express F400, R4 TL, R4 TL Savana, R5 Laureate/L, R5 Sociate (2382) (R2383), R5 Supercinq, R5 TL, R5 TL (R1222), R8, Super 5 C, Super 5 Societe C		65.02 2.560	71.88 2.830	COJINETE DE BIELA 1963-75	4B722 STD 010 020 030 040		TODOS
	1965-66	688/.12/.10, 688688.02, 688.01, 688.02/06/10/11, 688.09 (1.1L) (1108 cc) R4 GTL, (1128), R4 GTL, Clan (R1128), R4 TL Savane, R5 GTL (R1227)(R1397), R5 Laureate, GTL (R1397), TL, R5 Sociate (2387), R5 TL (R1227), R5 Turbo 2, R6 RODEO, R6 TL (R1181), R8 Major, R8 S (R1136), Rodeo 5 (ACL 2B) R10 (R1190) (R2398)(R2370)(R2430), R4 F4 Break, R4 F4, R4 F6, R4 Pick-up, R4 Fourgonette (R2108), R6 TL (R1181), R8 Major (R1132)S R8 S (R1136)		70.00 2.756	71.88 2.830	COJINETE DE BIELA 1976 -79	4B1005 STD 010 020 030 040 050		TODOS
	1964-69	CIE 715 (1.1L) (1108 cc) R11 TC Societe, R11 TC, GTC		70.00 2.750	71.88 2.830	COJINETE DE BANCADA 1969-72	5C1183 STD 010 020 030		2-4-5 1-3 (A, B)

Línea Line

1

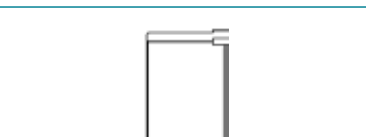
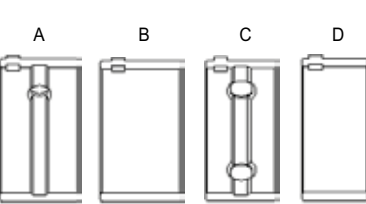

4 CILINDROS / 4 CYLINDER

MOTOR / ENGINE	AÑO / YEAR	LINEA / LINE
697.01 (1.5L)	1966-70	2
807 03/04/05/06 (1.6L)	1969-85	2
807 10/11 (1.6L)		2
807 12/13/20 (1.6L)		2
821 (9CV) (1.6L)		2
807 A 7 27 (1.6L)		2
843/841 (1.6L)	1973-77	2
841/841 (1.6L) (A2M)		2
841-99 (1.6L) A1M		2
K4M (1.6L)	1999-08	3

Diámetro Estándar del Muñón Standard Shaft Diameter	Diámetro Total del Alojamiento Housing Bore	Ancho del Cojinete Width Bearing	Espesor Máximo de Pared Max Wall Thickness	Claro de Lubricación Oil Clearance	Torque Torque	Imagen del Cojinete / Arandela Image of the Bearing and Thrust Washer
mm Pulgadas	mm Pulgadas	mm Pulgadas	mm Pulgadas	mm Pulgadas	N.m Lbs.Ft	
43.965/43.980 1.731/1.732	47.615/47.625 1.875/1.875	20.75 0.817	1.811 0.0713	0.0254/0.0660 0.0010/0.0026	34 N.m 25 Lbs.Ft	 8 Piezas
43.965/43.980 1.731/1.732	47.615/47.625 1.875/1.875	20.75 0.817	1.811 0.0713	0.0406/0.0660 0.0016/0.0026	34 N.m 25 Lbs.Ft 47 N.m 35 Lbs.Ft 1976-79	 8 Piezas
1.811/1.811 45.989/45.999	1.964/1.964 49.873/49.891	19.48 0.767	1.928 0.0759	0.0304/0.0736 0.0012/0.0029	61 N.m	 A: 4 Piezas B: 2 Piezas C: 3 Piezas D: 3 Piezas
45.989/45.999 1.811/1.811	49.873/49.891 1.964/1.964	24.49 0.964	1.928 0.0759	0.0304/0.0736 0.0012/0.0029	45 Lbs.Ft	

RENAULT

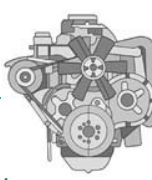
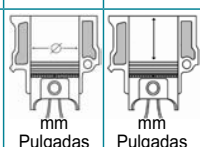
MORESA

CIL.	AÑO	MOTOR / APLICACIÓN			Diámetro del Cilindro Nominal Bore	Carrera Stroke	COJINETE, BUJE O ARANDELA	No. de Parte	Ubicación Location
CYL.	YEAR	ENGINE / APPLICATION			mm Pulgadas	mm Pulgadas	BEARING, BUSHING OR THURST WASHER	Part Number	
L4	1964-69	CIE 715 (1.1L) (1108 cc) R9 C,TC,GTC (L421)	70.00 2.756	71.88 2.834	COJINETE DE BANCADA 1976-79	5C1381 STD 010 020 030	1-2-3-4-5 (A, B)		
	1964-69	CIE,750/G750 (1.1L) (1108 cc) Express F401, R4 Fourgonete (R2108), Super 5 Five, Super 5 GL, L, Super 5 SL, Super 5 Societe GL, Super 5 TL,GTL	70.00 2.756	71.88 2.834					
	1969-79	810/25/26/29/03 (1.3L) (1289 cc) Alouette (R2136), Estafette Traffic 8001300, R10 1300, R12 L, LN, TN, TS, TR, TL, TXBreak, R15 TL, GTL, TR (R1300), R5 LS, TS, TL, GTL, USA, Automatic, R6 TL Export Colombia(R1189), Rodeo 6 (4D1128).	73.00 2.874	77.00 3.031					
		C1J,C2J,C3J,847 (1.4L) (1397 cc) Alliance USA, Express F 402, Express GTL, Fuego TL, GTL (R1360), R11 TL, GTL, Broadway 1.4, R11 TR, TL, GTL, GTS, TS, R12 Break Export (R1338), R12 TL Export (R1179), R18 L, TL, GTL, TL Break (R 1340), R18 TL Societe, R5 Automatique (R1229), R5 Laureate, Cabriolet, R5 Le Car (USA, Sweden), R5 Societe, R5 Supercing, GTL, GTS, TS, R5 TS, GTL, GTS, TSE (R1229), R5 TX, R5 TX Automatique, R9 Automatique (L42301), R9 Broadway 1.4, R9 TR, TL, GTL, TLE, TSE(L42200), R9 TS, GTS, TSE (142300), Super 5 Automatique, Super 5 GTL, GTS, TS, TSE	76.00 2.992	77.00 3.031	ARANDELA 1963-75	AM142 STD	2		
		847 700/701,C1J (1.4L) (1397 cc) Traffic Phase 11	76.00 2.992	77.00 3.031	ARANDELA 1976 -79	AM164 STD	3		
		CIJ 760/764/782 (1.4L) Turbocharged (1397 cc) R11 Turbo, R5 GT Turbo, R5 Laureate Alpine Turbo, R9 Turbo, Super 5 GT Turbo	76.00 2.992	77.00 3.031					
		CIJ,C2J,C3J (1.3L) (1397 cc) R19 Chamade TR, QTR, R19 TR, QTR, QTE, QTS, TS	76.00 2.992	77.00 3.031					
	840-25 (1.3L) (1397 cc) R5 Alpine	76.00 2.992	77.00 3.031						

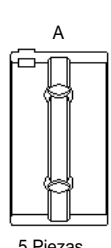
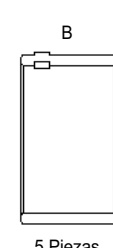

Línea Line

1

Diámetro Estándar del Muñón Standard Shaft Diameter	Diámetro Total del Alojamiento Housing Bore	Ancho del Cojinete Width Bearing	Espesor Máximo de Pared Max Wall Thickness	Claro de Lubricación Oil Clearance	Torque	Imagen del Cojinete / Arandela Image of the Bearing and Thrust Washer
mm Pulgadas	mm Pulgadas	mm Pulgadas	mm Pulgadas	mm Pulgadas	N.m Lbs.Ft	
54.783/54.793 2.157/2.157	58.730/58.748 2.312/2.313	19.48 0.767	1.948 0.0767	0.0127/0.0787 0.0005/0.0031	61 N.m 45 Lbs.Ft (1969-72) 65 N.m 48 Lbs.Ft (1976-79)	 5 Piezas  5 Piezas
68.257/0.000 2.687/0.000	51.161/0.000 2.014/0.000		2.311 0.0910			2 Piezas
60.500/60.749 2.382/2.392	79.751/80.000 3.140/3.150		2.799 0.1102			2 Piezas

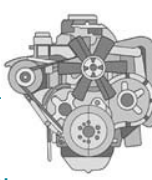
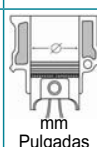
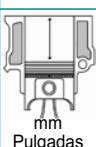

RENAULT

MORESA

CIL.	AÑO	MOTOR / APLICACIÓN		Diámetro del Cilindro Nominal Bore	Carrera Stroke	COJINETE, BUJE O ARANDELA	No. de Parte	Ubicación Location	
CYL.	YEAR	ENGINE / APPLICATION		 mm Pulgadas	 mm Pulgadas	BEARING, BUSHING OR THURST WASHER	Part Number	 1 2 3 4 5	
L4	1966-70	697.01 (1.5L) (1470 cc) R16 L, GL, R1150		76.00 2.992	81.00 3.189				
	1969-85	807 03/04/05/06 (1.6L) (1565 cc) R16 TS (R1151,R1154)		77.00 3.031	84.00 3.307		4B1202 STD 010 020 030 040	TODOS	
		807 10/11 (1.6L) (1565 cc) R17 TL,TA (R1312,R1322),R15 TS		77.00 3.031	84.00 3.307	COJINETE DE BIELA			
		807 12/13/20 (1.6L) (1565 cc) Fuego Turbo, R12 Gordini (R1173), R17 TS, Gordini (R1313,R1323), R18 Turbo 1600		77.00 3.031	84.00 3.307				
			821 (9CV) (1.6L) (1565 cc) R12 TI Break, Export(R1331), R12 TL,Export(R1172), R15 TL,Export (R1301), R16 9CV, R16 L,TL,(R1152,R1157), R16 TA Automatic(R1153)		77.00 3.031	84.00 3.307			
			807 A 7 27 (1.6L) (1565 cc) Fuego Turbo 1600(R1365-R136A), R 18 Turbo Type 2/Break, R18 Turbo 1600 (R1345)		77.00 3.031	84.00 3.307	COJINETE DE BANCADA	5C1140 STD 010 020 030	1-2-3-4-5 (A, B)
	1973-77	843/841 (1.6L) (1647 cc) Fuego GTL,GTS (R1362), R12 Break Export (R1332), R12 Break Export (R1334), R12 L,TL Export (R1174), R12 L,TL,TS Export R1178, R15 TL USA (1308), R16 TS (R1155), R16 TX, TA (1156), R17 TL USA (R1314,R1324), R17 TS Gordini (1316,R1326, R17 TS,Gordini (R1318,R1328), R18 GTS Break, R18 TS,GTS (R1342,R1352), R20 L,TL,GTL (R1271), R20 TL, GTL Automatic		79.00 3.110	84.00 3.307				
		841/841 (1.6L) (A2M) (1647 cc) A1M A2M, R18 American 2, R18 Automatic, R18 Break TS,GTS (R1350,R1351), R18 GTL, R18 GTL Break, R18 GTLBreak, R18 TS,GTS, Trafic P1000 -P3,1 -P5		79.00 3.110	84.00 3.307	ARANDELA	AM164 STD	3	
		841-99 (1.6L) A1M (1647 cc) Propulsion P3,0, P5/P6,OPA, Traction T1, T4, T5, T6, Trafic, Trafic 4x4		79.00 3.110	84.00 3.307				

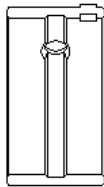

Línea Line

2

Diámetro Estándar del Muñón Standard Shaft Diameter	Diámetro Total del Alojamiento Housing Bore	Ancho del Cojinete Width Bearing	Espesor Máximo de Pared Max Wall Thickness	Claro de Lubricación Oil Clearance	Torque Torque	Imagen del Cojinete / Arandela Image of the Bearing and Thrust Washer
mm Pulgadas	mm Pulgadas	mm Pulgadas	mm Pulgadas	mm Pulgadas	N.m Lbs.Ft	
48.003/48.019 1.890/1.891	51.587/51.600 2.031/2.032	21.74 0.856	1.775 0.0699	0.0457/0.0889 0.0018/0.0035	41 N.m 30 Lbs.Ft	 8 Piezas
54.803/54.813 2.158/2.158	58.730/58.750 2.312/2.313	20.50 0.807	1.948 0.0767	0.0381/0.0838 0.0015/0.0033	61 N.m 45 Lbs.Ft	 5 Piezas  5 Piezas
60.500/60.749 2.382/2.392	79.751/80.000 3.140/3.150		2.799 0.1102			2 piezas

RENAULT

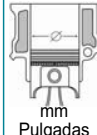
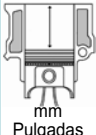
MORESA!

CIL.	AÑO	MOTOR / APLICACIÓN		Diámetro del Cilindro Nominal Bore	Carrera Stroke	COJINETE, BUJE O ARANDELA	No. de Parte	Ubicación Location
CYL.	YEAR	ENGINE / APPLICATION		 mm Pulgadas	 mm Pulgadas	BEARING, BUSHING OR THURST WASHER	Part Number	 → 1 2 3 4 5
L4	1999-08	K4M (1.6L) (1598 cc) CLIO, KANGOO		79.50 3.130	80.50 3.169	COJINETE DE BIELA	4B7002 STD 010 020	TODOS
						COJINETE DE BANCADA	5C7004 STD 010 020	1-2-3-4-5 (A, B)
						ARANDELA	AM7001 STD	3

Línea Line



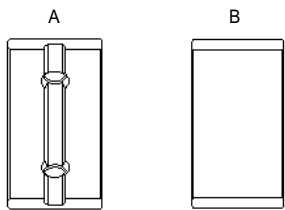

3





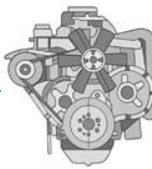

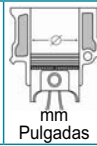
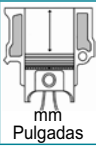
Diámetro Estándar del Muñón Standard Shaft Diameter	Diámetro Total del Alojamiento Housing Bore	Ancho del Cojinete Width Bearing	Esesor Máximo de Pared Max Wall Thickness	Claro de Lubricación Oil Clearance	Torque Torque	Imagen del Cojinete / Arandela Image of the Bearing and Thrust Washer
mm Pulgadas	mm Pulgadas	mm Pulgadas	mm Pulgadas	mm Pulgadas	N.m Lbs.Ft	
43.960/43.980 1.731/1.732	47.615/47.625 1.875/1.875	17.75 0.699	1.801 0.0709	0.0203/0.0685 0.0008/0.0027	43 N.m 32 Lbs.Ft	 8 Piezas
47.991/48.011 1.889/1.890	51.935/51.948 2.045/2.045	19.50 0.768	1.951 0.0768	0.0254/0.0762 0.0010/0.0030	24 N.m + 47° 18 Lbs.Ft + 47°	 5 Piezas 5 Piezas
53.500/53.749 2.106/2.116	73.500/74.000 2.894/2.913		2.819 0.1110			2 Piezas

SUZUKI

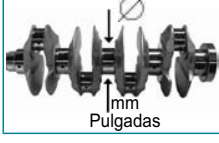
MORESA

4 CILINDROS / 4 CYLINDER		
MOTOR / ENGINE	AÑO / YEAR	LINEA / LINE
G13BA (1.3L) SOHC	1989-98	1
G13A (1.3L) SOHC	1986-89	1

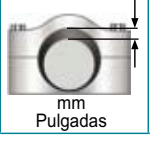

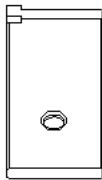
CIL.	AÑO	MOTOR / APLICACIÓN		Diámetro del Cilindro Nominal Bore	Carrera Stroke	COJINETE, BUJE O ARANDELA	No. de Parte		Ubicación Location
				 mm Pulgadas	 mm Pulgadas				
1	L4	1989-98	G13BA (1.3L) SOHC (1298 cc)	73.99 2.913	75.49 2.972	COJINETE DE BIELA	4B1401 STD 010 020 030		TODOS
	1986-89	G13A (1.3L) SOHC (1324 cc)	73.99 2.913	76.99 3.031					

Diámetro Estándar del Muñón Standard Shaft Diameter	Diámetro Total del Alojamiento Housing Bore	Ancho del Cojinete Width Bearing	Espesor Máximo de Pared Max Wall Thickness	Claro de Lubricación Oil Clearance	Torque Torque	Imagen del Cojinete / Arandela Image of the Bearing and Thrust Washer
 mm Pulgadas	 mm Pulgadas	 mm Pulgadas	 mm Pulgadas	 mm Pulgadas	 N.m Lbs.Ft	
41.986/42.012 1.653/1.654	44.983/45.009 1.771/1.772	18.11 0.713	1.491 0.0587	0.0203/0.0685 0.0008/0.0027	33 a 37 N.m 24 a 27 Lbs.Ft	 8 Piezas

TOYOTA

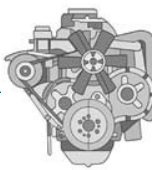

MORESA!

4 CILINDROS / 4 CYLINDER		
MOTOR / ENGINE	AÑO / YEAR	LINEA / LINE
3AC (1.5L) SOHC 8 valve	1979-90	1
1AC (1.5L) SOHC 8 valve	1978-80	1
5A (1.5L)	1987-	1
4ALC (1.6L) SOHC 8 valve	1983-88	1
4AC (1.6L) SOHC 8 valve	1983-87	1
4AF (1.6L) DOHC 16 valve	1988-89	1
4AFE (1.6L) DOHC 16 valve	1989-97	1
4AGEC (1.6L) DOHC 16 valve	1985-87	1
4AGELC (1.6L) DOHC 16 valve	1985-89	1
4AGZE (1.6L) Supercharged DOHC 16 valve	1987-89	1
4AGE (1.6L) DOHC 16 valve	1988-91	1
2TC (1.6L) OHV	1971-79	2
12T (1.6L)	1976-84	2
3TC (1.8L) OHV, 3T-G	1980-82	2
13T (1.8L)	1977-82	2

CIL.	AÑO	MOTOR / APLICACIÓN		Diámetro del Cilindro Nominal Bore		Carrera Stroke	COJINETE, BUJE O ARANDELA	No. de Parte	Ubicación Location
				mm Pulgadas	mm Pulgadas				
CYL.	YEAR	ENGINE / APPLICATION							
1	L4								
	1979-90	3AC (1.5L) SOHC 8 valve (1452 cc) Tercel, Corona, Carina	77.47 3.050	76.98 3.031	COJINETE DE BIELA	4B1361 STD 010 020 030	TODOS		
	1978-80	1AC (1.5L) SOHC 8 valve (1452 cc) Tercel, Carina	77.47 3.050	76.98 3.031					
	1987-	5A (1.5L) (1498 cc) Corona, Corolla	78.70 3.098	76.98 3.031					
	1983-88	4ALC (1.6L) SOHC 8 valve (1587 cc) Tercel, Corolla	81.00 3.189	76.98 3.031	COJINETE DE BANCADA	5C1638 STD 010 020 030 040	1-2-3-4-5 (A, B)		
1983-87	4AC (1.6L) SOHC 8 valve (1587 cc) Corolla	81.00 3.189	77.01 3.032						



4 CILINDROS / 4 CYLINDER

MOTOR / ENGINE	AÑO / YEAR	LINEA / LINE
4T-G (1.8L)	1982-84	2
8RC (1.9L) SOHC	1969-71	3
18RC (2.0L) SOHC	1972-74	3
2SELC (2.0L) SOHC 8 valve	1982-86	4
3SGELC (2.0L) DOHC 16 valve	1987-91	4
3SFE (2.0L) DOHC 16 valve	1987-00	4
3YEC (2.0L) OHV	1982-85	4
3SGTE (2.0L) Turbo DOHC 16 valve	1986-95	4
5SFE (2.2L) DOHC 16 valve	1985-01	4
20R (2.2L) SOHC 8 valve	1974-82	5
22R (2.4L) SOHC 8 valve	1980-90	5
22RE (2.4L) SOHC 8 valve	1989-95	5
22REC (2.4L) SOHC 8 valve	1983-88	5
22RTEC (2.4L) Turbo SOHC 8 valve	1985-88	5

Díámetro Estándar del Muñón Standard Shaft Diameter	Díámetro Total del Alojamiento Housing Bore	Ancho del Cojinete Width Bearing	Esesor Máximo de Pared Max Wall Thickness	Claro de Lubricación Oil Clearance	Torque Torque	Imagen del Cojinete / Arandela Image of the Bearing and Thurst Washer
mm Pulgadas	mm Pulgadas	mm Pulgadas	mm Pulgadas	mm Pulgadas	N.m Lbs.Ft	
39.980/40.000 1.574/1.575	43.000/43.025 1.693/1.694	17.09 0.673	1.491 0.0587	0.0177/0.0812 0.0007/0.0032	49 N.m 36 Lbs.Ft	 8 Piezas
47.981/48.001 1.889/1.890	52.019/52.045 2.048/2.049	19.89 0.783	2.004 0.0789	0.0152/0.0812 0.0006/0.0032	60 N.m 44 Lbs.Ft	 A 5 Piezas  B 5 Piezas

TOYOTA

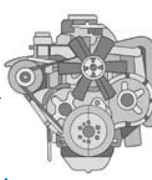
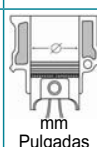
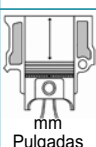

MORESA!

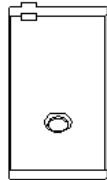
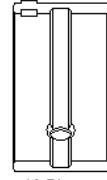
CIL.	AÑO	MOTOR / APLICACIÓN		Diámetro del Cilindro Nominal Bore	Carrera Stroke	COJINETE, BUJE O ARANDELA	No. de Parte	Ubicación Location
CYL.	YEAR	ENGINE / APPLICATION				BEARING, BUSHING OR THURST WASHER	Part Number	
1	L4							
	1988-89	4AF (1.6L) DOHC 16 valve (1587 cc) (Corolla)	81.00 3.190	77.01 3.032	ARANDELA	AM401 STD	3	
	1989-97	4AFE (1.6L) DOHC 16 valve (1587 cc) Celica, Corolla	81.00 3.190	77.01 3.032				
	1985-87	4AGEC (1.6L) DOHC 16 valve (1587 cc) Corolla	81.00 3.190	77.01 3.032				
	1985-89	4AGELC (1.6L) DOHC 16 valve (1587 cc) Corolla, MR2	81.00 3.190	77.01 3.032				
	1987-89	4AGZE (1.6L) Supercharged DOHC 16 valve (1587 cc) MR2	81.00 3.190	77.01 3.032				
1988-91	4AGE (1.6L) DOHC 16 valve (1587 cc)	81.00 3.190	77.01 3.032					
2	L4							
	1971-79	2TC (1.6L) OHV (1588 cc) Corolla	84.98 3.346	70.00 2.756	COJINETE DE BIELA	4B1270 STD 010 020 030 040	TODOS	
	1976-84	12T (1.6L) (1588 cc) Carina, Celica	84.98 3.346	70.00 2.756	COJINETE DE BANCADA	5C1456 STD 010 020 030 040	1-2-3-4-5	
	1980-82	3TC (1.8L) OHV, 3T-G (1770 cc) Corolla	84.98 3.346	78.00 3.071				
	1977-82	13T (1.8L) (1770 cc)	84.98 3.346	78.00 3.071	ARANDELA	AM303 STD	3	
1982-84	4T-G (1.8L) (1770 cc)	84.98 3.346	78.00 3.071					

Diámetro Estándar del Muñón Standard Shaft Diameter	Diámetro Total del Alojamiento Housing Bore	Ancho del Cojinete Width Bearing	Espesor Máximo de Pared Max Wall Thickness	Claro de Lubricación Oil Clearance	Torque Torque	Imagen del Cojinete / Arandela Image of the Bearing and Thrust Washer
mm Pulgadas	mm Pulgadas	mm Pulgadas	mm Pulgadas	mm Pulgadas	N.m Lbs.Ft	
53.500/53.749 2.106/2.116	65.999/66.251 2.598/2.608		2.489 0.0980			4 Piezas
47.978/47.991 1.889/1.889	51.003/51.024 2.008/2.009	19.91 0.784	1.494 0.0588	0.0355/0.0990 0.0014/0.0039	39 a 49 N.m 29 a 36 Lbs.Ft	 8 Piezas
57.976/58.001 2.283/2.284	61.999/62.024 2.441/2.442	20.80 0.819	1.994 0.0785	0.0228/0.0762 0.0009/0.0030	71 a 85 N.m 52 a 63 Lbs.Ft	 10 Piezas
64.049/64.300 2.522/2.532	75.999/76.251 2.992/3.002		2.489 0.0980			4 Piezas

TOYOTA

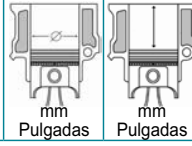
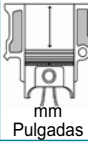
MORESA!

CIL.	AÑO	MOTOR / APLICACIÓN		Diámetro del Cilindro Nominal Bore	Carrera Stroke	COJINETE, BUJE O ARANDELA	No. de Parte	Ubicación Location
CYL.	YEAR	ENGINE / APPLICATION				BEARING, BUSHING OR THURST WASHER	Part Number	
L4	1969-71	8RC (1.9L) SOHC (1858 cc) Celica, Corona, Cressida	86.00 3.386	80.01 3.150	COJINETE DE BIELA	4B1218 STD 010 020 030	TODOS	
	1972-74	18RC (2.0L) SOHC (1968 cc) Celica, Corona, Cressida, Hi-Lux, Pick-up	88.50 3.484	80.01 3.150				COJINETE DE BANCADA
							3 (B)	
					ARANDELA	AM326 STD	2	
L4	1982-86	2SEL (2.0L) SOHC 8 valve (1995 cc) Camry, Celica, Carina	83.99 3.307	90.00 3.543	COJINETE DE BANCADA 1987-91 3SGELC DOHC 16 valve 1987-00 3SFE DOHC 16 valve 1986-95 3SGTE Turbo DOHC 16 valve 1985-01 5SFE DOHC 16 valve	5C1714 STD 010 020 030 040	1-2-4-5 (A, B)	
	1987-91	3SGELC (2.0L) DOHC 16 valve (1998 cc) Camry, Celica, Ipsum, Rav 4, Townace, Vista	86.00 3.386	86.00 3.386				3 (C, D)
	1987-00	3SFE (2.0L) DOHC 16 valve (1998 cc) Camry, Celica, Rav 4	86.00 3.386	86.00 3.386				
	1982-85	3YEC (2.0L) OHV (1998 cc) Liteace, Townace, Hi-lux, Van	86.00 3.386	86.00 3.386	ARANDELA	AM303 STD	3	
	1986-95	3SGTE (2.0L) Turbo DOHC 16 valve (1998 cc) Celica, All-Trac, MR2	86.03 3.386	86.00 3.386				
	1985-01	5SFE (2.2L) DOHC 16 valve (2164 cc) Camry, Celica, MR2, Rav 4, Solera	87.00 3.426	91.00 3.583				



Línea Line
3

4





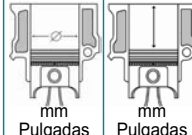
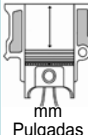



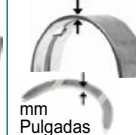
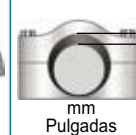

Diámetro Estándar del Muñón Standard Shaft Diameter	Diámetro Total del Alojamiento Housing Bore	Ancho del Cojinete Width Bearing	Espesor Máximo de Pared Max Wall Thickness	Claro de Lubricación Oil Clearance	Torque Torque	Imagen del Cojinete / Arandela Image of the Bearing and Thrust Washer
52.969/52.989 2.085/2.086	55.999/56.025 2.205/2.206	22.00 0.866	1.491 0.0587	0.0203/0.0939 0.0008/0.0037	57 a 65 N.m 42 a 48 Lbs.Ft	 8 Piezas
59.977/60.000 2.361/2.362	64.000/64.023 2.520/2.521	22.00 0.866	1.991 0.0784	0.0152/0.0914 0.0006/0.0036	98 a 113 N.m 72 a 83 Lbs.Ft	 8 Piezas
59.977/60.000 2.361/2.362	64.000/64.023 2.520/2.521	35.99 1.417	1.991 0.0784	0.0152/0.0914 0.0006/0.0036		 2 Piezas
65.999/66.251 2.598/2.608	80.000/80.249 3.150/3.159		1.989 0.0783			4 piezas
54.981/55.001 2.165/2.165	59.019/59.037 2.324/ 2.324	19.20 0.756	1.999 0.0787	0.0203/0.0889 0.0008/0.0035	58 N.m 43 Lbs.Ft	 4 Piezas
54.981/55.001 2.165/2.165	59.019/59.037 2.324/2.324	23.00 0.906	1.994 0.0785	0.0203/0.0889 0.0008/0.0035		 4 Piezas
						 1 Pieza
						 1 Pieza
64.049/64.300 2.522/2.532	75.999/76.251 2.992/3.002		2.489 0.0980			4 Piezas

TOYOTA

MORESA!

CIL.	AÑO	MOTOR / APLICACIÓN		Diámetro del Cilindro Nominal Bore	Carrera Stroke	COJINETE, BUJE O ARANDELA	No. de Parte	Ubicación Location
CYL.	YEAR	ENGINE / APPLICATION		 mm Pulgadas	 mm Pulgadas	BEARING, BUSHING OR THURST WASHER	Part Number	
L4	1974-82	20R (2.2L) SOHC 8 valve (2189 cc)	88.39 3.480	89.00 3.504				
	1980-90	Celica, Corona, Hi-Lux, Pick-up 22R (2.4L) SOHC 8 valve (2366 cc) 4Runner, Celica, Corona, Pick-up	92.00 3.622	88.90 3.500	COJINETE DE BIELA	4B1218 STD 010 020 030	TODOS	
	1989-95	22RE (2.4L) SOHC 8 valve (2366 cc) 4Runner, Pick-up	92.00 3.622	88.90 3.500			1-2-4-5 (A)	
	1983-88	22REC (2.4L) SOHC 8 valve (2366 cc) Celica, 4Runner, Pick-up	92.00 3.622	88.90 3.500	COJINETE DE BANCADA 1974 - 82	5C1428 STD 010 020 030	3 (B)	
	1985-88	22RTEC (2.4L) Turbo SOHC 8 valve (2366 cc) 4Runner, Pick-up	92.00 3.622	88.90 3.500				
						COJINETE DE BANCADA 1983 - 95	5C1590 STD 010 020 030	1-2-3-4-5 (A, B)
					ARANDELA 1982 - 84	AM326 STD	3	
					ARANDELA 1984 - 95	AM463 STD	3	

Línea Line
5



Diámetro Estándar del Muñón Standard Shaft Diameter	Diámetro Total del Alojamiento Housing Bore	Ancho del Cojinete Width Bearing	Espesor Máximo de Pared Max Wall Thickness	Claro de Lubricación Oil Clearance	Torque Torque	Imagen del Cojinete / Arandela Image of the Bearing and Thrust Washer
						
52.969/52.989 2.085/2.086	55.999/56.025 2.205/2.206	22.00 0.866	1.491 0.0587	0.0203/0.0939 0.0008/0.0037	57 a 65 N.m 42 a 48 Lbs.Ft	 8 Piezas
59.977/60.000 2.361/2.362	64.000/64.023 2.520/2.521	22.00 0.866	1.991 0.0784	0.0152/0.0914 0.0006/0.0036	98 a 109 N.m	 8 Piezas
59.977/60.000 2.361/2.362	64.000/64.023 2.520/2.521	23.88 0.940	1.991 0.0784	0.0127/0.1117 0.0005/0.0044	72 a 80 Lbs.Ft	 2 Piezas
59.977/60.000 2.361/2.362	64.000/64.023 2.520/2.521	22.00 0.866	1.991 0.0784	0.0152/0.0838 0.0006/0.0033	98 a 109 N.m 72 a 80 Lbs.Ft	 5 Piezas
65.999/66.251 2.598/2.608	80.000/80.249 3.150/3.159		1.989 0.0783			 5 Piezas
65.999/66.251 2.598/2.608	80.000/80.249 3.150/3.159		2.741 0.1079			4 Piezas
65.999/66.251 2.598/2.608	80.000/80.249 3.150/3.159					4 Piezas

VAM (RAMBLER)

MORESA!

4 CILINDROS / 4 CYLINDER		
MOTOR / ENGINE	AÑO / YEAR	LINEA / LINE
150 (2.5L)	1983-88	1
151 (2.5L) Pontiac Engine	1980-83	2

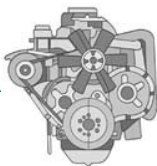
6 CILINDROS / 6 CYLINDER		
MOTOR / ENGINE	AÑO / YEAR	LINEA / LINE
199 (3.3L)	1965-70	3
232 (3.8L)	1964-79	3
258 (4.2L)	1971-88	3

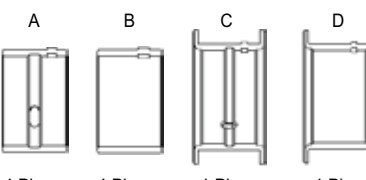

CIL.	AÑO	MOTOR / APLICACIÓN		Diámetro del Cilindro		Carrera	COJINETE, BUJE O ARANDELA	No. de Parte	Ubicación	
				Nominal	Bore					Stroke
CYL.	YEAR	ENGINE / APPLICATION		mm	Pulgadas	mm	Pulgadas	Part Number		
1	L4	1983-88 150 (2.5L) (2460 cc) Eagle, Premier		98.42	3.875	80.97	3.188	COJINETE DE BIELA	4B960	1
									STD	
								COJINETE DE BANCADA	010	1-3-4-5 (A, B)
									020	
	030	2 (C, D)								
			040							
								BUJE DE ARBOL	MO1244M	2
									STD	
									010	3
										4

8 CILINDROS / 8 CYLINDER		
MOTOR / ENGINE	AÑO / YEAR	LÍNEA / LINE
290 (4.7L)	1966-69	4
304 (5.0L)	1970-79	4
343 (5.6L)	1967-69	4
360 (5.9L)	1970-78	4

Diámetro Estándar del Muñón Standard Shaft Diameter	Diámetro Total del Alojamiento Housing Bore	Ancho del Cojinete Width Bearing	Espesor Máximo de Pared Max Wall Thickness	Claro de Lubricación Oil Clearance	Torque Torque	Imagen del Cojinete / Arandela Image of the Bearing and Thrust Washer
mm Pulgadas	mm Pulgadas	mm Pulgadas	mm Pulgadas	mm Pulgadas	N.m Lbs.Ft	
53.208/53.226 2.095/2.096	56.083/56.096 2.208/2.209	21.26 0.837	1.422 0.0560	0.0254/0.0863 0.0012/0.0034	45 N.m 33 Lbs.Ft	 8 Piezas
63.470/63.487 2.499/2.500	68.351/68.377 2.691/2.692	25.04 0.986	2.421 0.0953	0.0152/0.0812 0.0006/0.0031	109 N.m 80 Lbs.Ft	 4 Piezas 4 Piezas 1 Pieza 1 Pieza
63.470/63.487 2.499/2.500	68.351/68.377 2.691/2.692	32.26 1.270	2.421 0.0953	0.0152/0.0812 0.0006/0.0031		
51.549/51.575 2.030/2.031	54.750/54.775 2.156/2.157	17.53 0.690	1.575 0.0620	0.0254/0.1270 0.0010/0.0050		1 Pieza
51.295/51.321 2.020/2.021	54.496/54.521 2.146/2.147	17.53 0.690	1.575 0.0620	0.0254/0.1270 0.0010/0.0050		1 Pieza
51.041/51.067 2.010/2.011	54.242/54.267 2.136/2.137	17.53 0.690	1.575 0.0620	0.0254/0.1270 0.0010/0.0050		1 Pieza
50.787/50.813 2.000/2.001	53.988/54.013 2.126/2.127	17.53 0.690	1.575 0.0620	0.0254/0.1270 0.0010/0.0050		1 Pieza

VAM (RAMBLER)

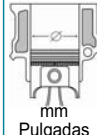
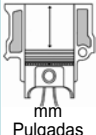





MORESA!

CIL.	AÑO	MOTOR / APLICACIÓN		Diámetro del Cilindro Nominal Bore	Carrera Stroke	COJINETE, BUJE O ARANDELA	No. de Parte	Ubicación
				 mm Pulgadas	 mm Pulgadas	BEARING, BUSHING OR THURST WASHER		
L4	1980-83	151 (2.5L) Pontiac Engine (2500 cc) AMX (Spirit/Concord), Concord, Eagle, Kammback, SX-4, Spirit		101.60 4.000	76.20 3.000	COJINETE DE BIELA	4B610 STD 010 020 030 040	TODOS
						COJINETE DE BANCADA	5C1733 STD 010 020 030	1-2-3-4 (A, B)
						BUJE DE ARBOL	MO1461M STD	5 (C, D)
								1-2-3

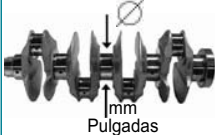
Línea
Line
2

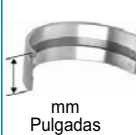
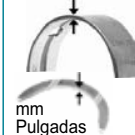

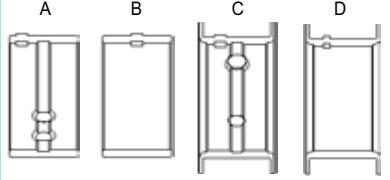

MORESA

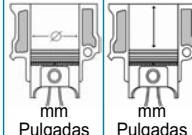
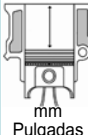

VAM (RAMBLER)

Diámetro Estándar del Muñón Standard Shaft Diameter	Diámetro Total del Alojamiento Housing Bore	Ancho del Cojinete Width Bearing	Espesor Máximo de Pared Max Wall Thickness	Claro de Lubricación Oil Clearance	Torque Torque	Imagen del Cojinete / Arandela Image of the Bearing and Thrust Washer
						
50.787/50.813 2.000/2.001	53.967/53.980 2.125/2.125	18.85 0.742	1.575 0.0620	0.0177/0.0812 0.0007/0.0032	43 N.m 32 Lbs.Ft	 8 Piezas
58.377/58.402 2.298/2.299	63.261/63.287 2.491/2.492	20.50 0.807	2.426 0.0955	0.0152/0.0914 0.0006/0.0036	88 a 95 N.m	
58.377/58.402 2.298/2.299	63.246/63.287 2.490/2.492	25.63 1.009	2.426 0.0955	0.0152/0.0914 0.0006/0.0036	65 a 70 Lbs.Ft	4 Piezas 4 Piezas 1 Pieza 1 Pieza
47.452/47.478 1.868/1.869	50.775/50.825 1.999/2.001	21.97 0.865	1.636 0.0644	0.0127/0.1270 0.0005/0.0050		3 Piezas

VAM (RAMBLER)

MORESA

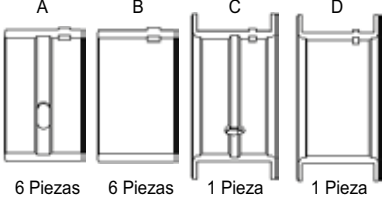

CIL.	AÑO	MOTOR / APLICACIÓN		Diámetro del Cilindro Nominal Bore	Carrera Stroke	COJINETE, BUJE O ARAÑDELA	No. de Parte	Ubicación Location
CYL.	YEAR	ENGINE / APPLICATION		 mm Pulgadas	 mm Pulgadas	BEARING, BUSHING OR THURST WASHER	Part Number	
3	L6	1965-70	199 (3.3L) (3256 cc) American, Classic, Gremlin, Hornet, Rambler	95.25 3.750	76.20 3.000	COJINETE DE BIELA	6B960 STD 010 020 030 040 050	 TODOS
		1964-79	232 (3.8L) (3800 cc) AMX (Javelin), Ambassador, American, Classic, Concord, Gremlin, Hornet, Javelin, Marlin, Matador, Pacer, Rambler, Rebel, Spirit, Typhoon	95.25 3.750	88.90 3.500			
		1971-88	258 (4.2L) (4200 cc) AMX (Javelin), AMX (Spirit/Concord), Ambassador, Concord, Eagle, Gremlin, Hornet, Javelin, Kamback, Matador, Pacer, SX-4, Spirit	95.25 3.750	98.93 3.895	BUJE DE ARBOL	MO1244M STD 010	3 (C, D)
								2
								3
								4
4	V8	1966-69	290 (4.7L) (4746 cc) AMX (Javelin), Ambassador, American, Javelin, Marlin, Rambler, Rebel	95.25 3.750	83.31 3.280	COJINETE DE BIELA	8B960 STD 010 020 030 040	 TODOS
		1970-79	304 (5.0L) (4973 cc) AMX (Javelin), AMX (Spirit/Concord), Ambassador, Concord, Gremlin, Hornet, Javelin, Matador, Pacer, Rebel, Spirit	95.15 3.746	87.38 3.440			
		1967-69	343 (5.6L) (5600 cc) AMX (Javelin), Ambassador, American, Javelin, Marlin, Rebel	103.63 4.080	83.31 3.280			
		1970-78	360 (5.9L) (5900 cc) AMX (Javelin), Ambassador, Concord, Hornet, Javelin, Matador, Rebel	103.63 4.080	87.38 3.440			

Diámetro Estándar del Muñón Standard Shaft Diameter	Diámetro Total del Alojamiento Housing Bore	Ancho del Cojinete Width Bearing	Espesor Máximo de Pared Max Wall Thickness	Claro de Lubricación Oil Clearance	Torque	Imagen del Cojinete / Arandela Image of the Bearing and Thrust Washer
mm Pulgadas	mm Pulgadas	mm Pulgadas	mm Pulgadas	mm Pulgadas	N.m Lbs.Ft	
53.208/53.226 2.095/2.096	56.083/56.096 2.208/2.209	21.26 0.837	1.422 0.0560	0.0304/0.0863 0.0012/0.0034	37 a 41 N.m 27 a 30 Lbs.Ft	 12 Piezas
63.470/63.487 2.499/2.500	68.351/68.377 2.691/2.692	25.04 0.986	2.421 0.0953	0.0152/0.0787 0.0006/0.0031	102 a 115 N.m	 A: 6 Piezas, B: 6 Piezas, C: 1 Pieza, D: 1 Pieza
63.470/63.487 2.499/2.500	68.351/68.377 2.691/2.692	32.26 1.270	2.421 0.0953	0.0152/0.0787 0.0006/0.0031	75 a 85 Lbs.Ft	
51.549/51.575 2.030/2.031	54.750/54.775 2.156/2.157	17.53 0.690	1.575 0.0620	0.0254/0.1270 0.0010/0.0050		1 Pieza
51.295/51.321 2.020/2.021	54.496/54.521 2.146/2.147	17.53 0.690	1.575 0.0620	0.0254/0.1270 0.0010/0.0050		1 Pieza
51.041/51.067 2.010/2.011	54.242/54.267 2.136/2.137	17.53 0.690	1.575 0.0620	0.0254/0.1270 0.0010/0.0050		1 Pieza
50.787/50.813 2.000/2.001	53.988/54.013 2.126/2.127	17.53 0.690	1.575 0.0620	0.0254/0.1270 0.0010/0.0050		1 Pieza
53.208/53.226 2.095/2.096	56.083/56.096 2.208/2.209	21.26 0.837	1.422 0.0560	0.0304/0.0863 0.0012/0.0034	41 N.m 30 Lbs.Ft 360 5.9L 129 a 142 N.m 95 a 105 Lbs.Ft (304 5.0L) Relación de Compresión 8.4:1	 16 Piezas

VOLKSWAGEN

MORESA

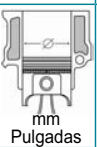
4 CILINDROS / 4 CYLINDER		
MOTOR / ENGINE	AÑO / YEAR	LINEA / LINE
1200 (1.2L) 112,113,126	1966-04	1
1300 (1.3L)	1966-04	1
1500 (1.5L) 311,341	1966-04	1
1600 (1.6L) 122,126,211,311	1966-04	1
EH, FX (1.5L)	1978-80	2
CK DIESEL (1.5L)	1977-80	2
FC, FG, XR, XS, XV, XW, XY, XZ (1.5L)	1974-75	2
EE, EJ, FN, YG, YH, YK (1.6L)	1976-80	2
CR, CS, JK DIESEL (1.6L)	1981-84	3
ME DIESEL (1.6L)	1985	3
CY, MD, MF (1.6L) Turbocharged	1982-86	3
(1.6L) SOHC 8 valve Turbocharged	1992	3
SOHC (1.6L)	1981-85	4
SOHC (1.7L)	1979-	4

CIL.	AÑO	MOTOR / APLICACIÓN		Diámetro del Cilindro Nominal Bore	Carrera Stroke	COJINETE, BUJE O ARANDELA	No. de Parte	Ubicación Location			
				mm Pulgadas	mm Pulgadas				BEARING, BUSHING OR THURST WASHER	Part Number	
L4	1954-65	1200 (1.2L) 112,113,126 (1192 cc) 1200,1303, Indust. Engine 122, Microbus,Kombi,1200 15Cwt Van, Sedan		77.00 3.031	64.00 2.520	COJINETE DE BIELA	4B780 STD 010 020 030 040 050 060	 TODOS			
	1966	1300 (1.3L) (1285 cc) 1300, Cabriolet, Karmann Ghia, 1302, 1303, Sedan		77.00 3.031	69.00 2.717				COJINETE DE BANCADA Medida Exterior STD (65.018mm) Ceja STD (2.5mm)	4C822 STD 010 020 030	1 (A)
	1967-69	1500 (1.5L) 311,341 (1493 cc) 1500A Transporter, 1500N (311 Eng), 1500S (341 Eng), 1600A Transporter, 181 R.W.D Air Cooled, Sedan		83.00 3.268	68.99 2.716						2 (B, C)
	1968-04	1600 (1.6L) 122,126,211,311 (1584 cc) 1200, 1302S, 1302S (126 Eng), 1303S/LS, 1600 Karmann Ghia, 1600 Transporter (211Eng), 1600TL, Instudy Engine 126, Variant 1600A/L/TL, Sedan		85.50 3.366	69.00 2.717				3 (D)		
								4 (E)			

Línea Line

1

4 CILINDROS / 4 CYLINDER		
MOTOR / ENGINE	AÑO / YEAR	LINEA / LINE
(1.8L) SOHC JH, JN	1983-89	4
(1.8L) DOHC PL	1986-89	4
2H, ABG, HT, PF, PG, RD, RV, UM (1.8L) Supercharged	1990-92	4
1800 (1.8L) A, G, J series - K, P, R series -	1982-	5
2000 (2.0L) A, KR, 2E, 9A seri-	1990-	5
9A DOHC (2.0L)	1990-94	6
ABA (2.0L) SOHC	1993-98	6

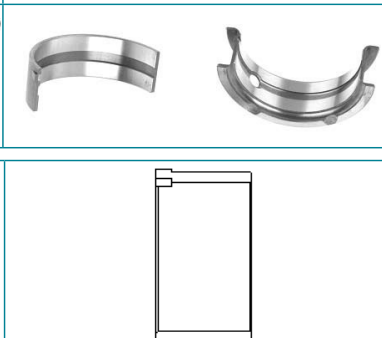
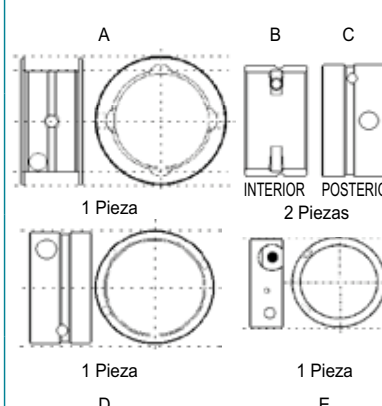

5 CILINDROS / 5 CYLINDER		
MOTOR / ENGINE	AÑO / YEAR	LINEA / LINE
2500 (2.5L) AAF, ACU, AET, AEU	2001-05	7

6 CILINDROS / 6 CYLINDER		
MOTOR / ENGINE	AÑO / YEAR	LINEA / LINE
2500 (2.5L) AAF, ACU, AET, AEU	2001-05	8





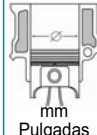
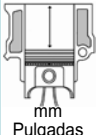





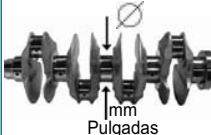

Díámetro Estándar del Muñón Standard Shaft Diameter	Díámetro Total del Alojamiento Housing Bore	Ancho del Cojinete Width Bearing	Espesor Máximo de Pared Max Wall Thickness	Claro de Lubricación Oil Clearance	Torque Torque	Imagen del Cojinete / Arandela Image of the Bearing and Thurst Washer
mm Pulgadas	mm Pulgadas	mm Pulgadas	mm Pulgadas	mm Pulgadas	N.m Lbs.Ft	
54.971/54.991 2.164/2.165	57.800/57.818 2.276/2.276	17.60 0.693	1.397 0.0550	0.0254/0.0889 0.0010/0.0035	30 a 34 N.m 22 a 25 Lbs.Ft	 8 Piezas
54.970/55.991 2.1642/2.1650	65.001/65.018 2.5591/2.5598	26.95 1.061	4.986 0.1963	0.0381/0.0965 0.0015/0.0038	49 N.m 36 Lbs.Ft	 A: 1 Pieza B: INTERIOR C: POSTERIOR D: 1 Pieza E: 1 Pieza
54.970/55.991 2.1642/2.1650	65.001/65.018 2.5591/2.5598	22.00 0.866	5.034 0.1982	0.0127/0.0711 0.0005/0.0028		
54.970/55.991 2.1642/2.1650	65.001/65.018 2.5591/2.5598	22.00 0.866	4.991 0.1965	0.0279/0.0914 0.0011/0.0036		
39.984/39.999 1.5742/1.5748	42.799/50.015 1.9685/1.9691	15.01 0.591	4.983 0.1962	0.0330/0.0838 0.0013/0.0033		

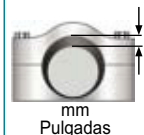
VOLKSWAGEN

MORESA!

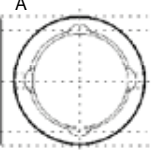
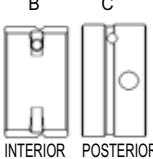

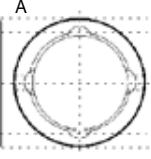
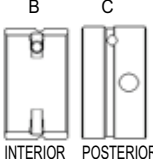
CIL.	AÑO	MOTOR / APLICACIÓN		Diámetro del Cilindro Nominal Bore	Carrera Stroke	COJINETE, BUJE O ARANDELA	No. de Parte	Ubicación Location
CYL.	YEAR	ENGINE / APPLICATION		 mm Pulgadas	 mm Pulgadas	BEARING, BUSHING OR THURST WASHER	Part Number	
L4	1954-65	1200 (1.2L) 112,113,126 (1192 cc) 1200,1303, Indust. Engine 122, Microbus,Kombi,1200 15Cwt Van, Sedan	77.00 3.031	64.00 2.520	COJINETE DE BANCADA Sobre Medida Exterior 0.50mm (0.020") Ceja + 1mm	4C943 STD 010 020 030 040	1 (A)	
	1966	1300 (1.3L) (1285 cc) 1300, Cabriolet, Karmann Ghia, 1302, 1303, Sedan	77.00 3.031	69.00 2.717			2 (B, C)	
							3 (D)	
							4 (E)	
	1967-69	1500 (1.5L) 311,341 (1493 cc) 1500A Transporter, 1500N (311 Eng), 1500S (341 Eng), 1600A Transporter, 181 R.V.D Air Cooled, Sedan	83.00 3.268	68.99 2.716	1 (A)			
	1968-04	1600 (1.6L) 122,126,211,311 (1584 cc) 1200, 1302S, 1302S (126 Eng), 1303S/LS, 1600 Karmann Ghia, 1600 Transporter (211Eng), 1600TL, Instudy Engine 126, Variant 1600A/L/TL, Sedan	85.50 3.366	69.00 2.717	COJINETE DE BANCADA Sobre Medida Exterior 1.00mm (0.040") Ceja + 1mm	4C1053 STD 010 020 030	2 (B, C)	
							3 (D)	
					COJINETE DE BANCADA Sobre Medida Exterior 1.50mm (0.060") Ceja + 2mm	4C1416 STD 010 020 030	4 (E)	
							1 (A)	
	2 (B, C)							
	3 (D)							
	4 (E)							

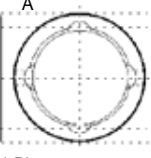
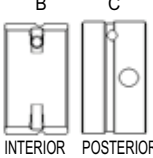



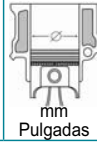
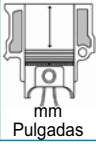

Línea Line
1

Diámetro Estándar del Muñón Standard Shaft Diameter	Diámetro Total del Alojamiento Housing Bore	Ancho del Cojinete Width Bearing	Espesor Máximo de Pared Max Wall Thickness	Claro de Lubricación Oil Clearance	Torque Torque	Imagen del Cojinete / Arandela Image of the Bearing and Thrust Washer
						
54.970/55.991 2.1642/2.1650	65.425/65.519 2.5787/2.5795	26.95 1.061	5.237 0.2062	0.0381/0.0965 0.0015/0.0038	49 N.m 36 Lbs.Ft	   1 Pieza INTERIOR POSTERIOR 2 Piezas
54.970/55.991 2.1642/2.1650	65.425/65.519 2.5787/2.5795	22.00 0.866	5.286 0.2081	0.0127/0.0711 0.0005/0.0028		
54.970/55.991 2.1642/2.1650	65.425/65.519 2.5787/2.5795	22.00 0.866	5.240 0.2063	0.0279/0.0914 0.0011/0.0036		
39.984/39.999 1.5742/1.5748	50.500/50.515 1.9882/1.9888	15.01 0.591	5.232 0.2060	0.0330/0.0838 0.0013/0.0033		
54.970/55.991 2.1642/2.1650	65.999/66.020 2.5984/2.5992	26.95 1.061	5.486 0.2160	0.0381/0.0965 0.0015/0.0038	49 N.m 36 Lbs.Ft	   1 Pieza INTERIOR POSTERIOR 2 Piezas
54.970/55.991 2.1642/2.1650	65.999/66.020 2.5984/2.5992	22.00 0.866	5.535 0.2179	0.0127/0.0711 0.0005/0.0028		
54.970/55.991 2.1642/2.1650	65.999/66.020 2.5984/2.5992	22.00 0.866	5.489 0.2161	0.0279/0.0914 0.0011/0.0036		
39.984/39.999 1.5742/1.5748	50.998/51.015 2.0078/2.0085	15.01 0.591	5.484 0.2159	0.0330/0.0838 0.0013/0.0033		
54.970/55.991 2.1642/2.1650	66.502/66.520 2.6182/2.6189	26.95 1.061	5.735 0.2258	0.0381/0.0965 0.0015/0.0038	49 N.m 36 Lbs.Ft	   1 Pieza INTERIOR POSTERIOR 2 Piezas
54.970/55.991 2.1642/2.1650	66.502/66.520 2.6182/2.6189	22.00 0.866	5.783 0.2277	0.0127/0.0711 0.0005/0.0028		
54.970/55.991 2.1642/2.1650	66.502/66.520 2.6182/2.6189	22.00 0.866	5.740 0.2260	0.0279/0.0914 0.0011/0.0036		
39.984/39.999 1.5742/1.5748	51.498/51.523 2.0275/2.0285	15.01 0.591	5.753 0.2265	0.0330/0.0838 0.0013/0.0033		

VOLKSWAGEN

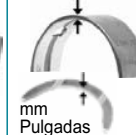
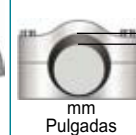

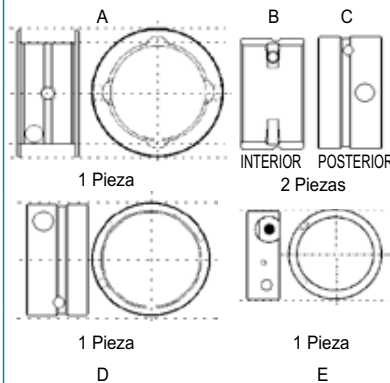
MORESA!

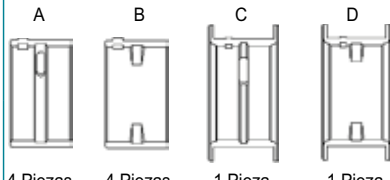
CIL.	AÑO	MOTOR / APLICACIÓN		Diámetro del Cilindro Nominal Bore	Carrera Stroke	COJINETE, BUJE O ARANDELA	No. de Parte	Ubicación Location
CYL.	YEAR	ENGINE / APPLICATION				BEARING, BUSHING OR THURST WASHER	Part Number	
1	L4							
	1954-65	1200 (1.2L) 112,113,126 (1192 cc) 1200,1303, Indust. Engine 122, Microbus,Kombi,1200 15Cwt Van, Sedan	77.00 3.031	64.00 2.520				1 (A)
	1966	1300 (1.3L) (1285 cc) 1300, Cabriolet, Karmann Ghia, 1302, 1303, Sedan	77.00 3.031	69.00 2.717	COJINETE DE BANCADA Sobre Medida Exterior 2.00mm (0.080") Ceja + 2mm	4C1417 STD 010 020 030		2 (B, C)
	1967-69	1500 (1.5L) 311,341 (1493 cc) 1500A Transporter, 1500N (311 Eng), 1500S (341 Eng), 1600A Transporter, 181 R.W.D Air Cooled, Sedan	83.00 3.268	68.99 2.716				3 (D)
	1968-04	1600 (1.6L) 122,126,211,311 (1584 cc) 1200, 1302S, 1302S (126 Eng), 1303S/LS, 1600 Karmann Ghia, 1600 Transporter (211Eng), 1600TL, Instudy Engine 126, Variant 1600A/L/TL, Sedan	85.50 3.366	69.00 2.717	BUJE	MO1713M STD		4 (E) 1 2 3
2	L4							
	1978-80	EH, FX (1.5L) (1457 cc) Caddy, Golf, Jetta, Scirocco	79.50 3.130	73.40 2.890	COJINETE DE BIELA Sin barrenos, para diámetro de muñón 46 mm	4B1017 STD 010 020 030 040 050		TODOS
	1977-80	CK DIESEL (1.5L) (1471 cc) Golf, Jetta, Scirocco	79.50 3.130	73.40 2.890				
	1974-75	FC, FG, XR, XS, XV, XW, XY, XZ (1.5L) (1471 cc) Golf, Jetta, Scirocco	76.05 2.994	80.00 3.150	COJINETE DE BANCADA	5C1157 STD 010 020 030		1-2-4-5 (A, B)
	1976-80	EE, EJ, FN, YG, YH, YK (1.6L) (1588 cc) Rabbit, Atlantic, Caribe, Scirocco	79.50 3.130	80.00 3.150	BUJE	MO1726M STD		3 (C, D) 1 2

Diámetro Estándar del Muñón Standard Shaft Diameter	Diámetro Total del Alojamiento Housing Bore	Ancho del Cojinete Width Bearing	Espesor Máximo de Pared Max Wall Thickness	Claro de Lubricación Oil Clearance	Torque Torque	Imagen del Cojinete / Arandela Image of the Bearing and Thrust Washer	
							
54.970/55.991 2.1642/2.1650	67.000/67.017 2.6378/2.6385	26.95 1.061	5.984 0.2356	0.0381/0.0965 0.0015/0.0038	49 N.m 36 Lbs.Ft	 <p>A B C 1 Pieza INTERIOR POSTERIOR 2 Piezas D E</p>	
54.970/55.991 2.1642/2.1650	67.000/67.017 2.6378/2.6385	22.00 0.866	6.032 0.2375	0.0127/0.0711 0.0005/0.0028			
54.970/55.991 2.1642/2.1650	67.000/67.017 2.6378/2.6385	22.00 0.866	5.989 0.2358	0.0279/0.0914 0.0011/0.0036			
39.984/39.999 1.5742/1.5748	51.998/52.014 2.0472/2.0478	15.01 0.591	5.981 0.2355	0.0330/0.0838 0.0013/0.0033			
24.9859/25.0012 0.9837/0.9843	27.5005/27.5207 1.0827/1.0835	19.91 0.784	1.244 0.0490	0.0228/0.0787 0.0009/0.0031			1 Pieza
24.9859/25.0012 0.9837/0.9843	27.5005/27.5207 1.0827/1.0835	22.91 0.902	1.244 0.0490	0.0228/0.0787 0.0009/0.0031			1 Pieza
24.9859/25.0012 0.9837/0.9843	27.5005/27.5207 1.0827/1.0835	27.99 1.102	1.244 0.0490	0.0228/0.0787 0.0009/0.0031			1 Pieza
45.938/45.959 1.809/1.809	48.999/49.014 1.929/1.930	19.00 0.748	1.506 0.0593	0.0406/0.1016 0.0016/0.0040	45 N.m 33 Lbs.Ft	 8 Piezas	
53.957/53.978 2.124/2.125	58.999/59.017 2.323/2.324	18.49 0.728	2.502 0.0985	0.0406/0.1041 0.0016/0.0041	64 a 68 N.m 47 a 50 Lbs.Ft	 <p>A B C D 4 Piezas 4 Piezas 1 Pieza 1 Pieza</p>	
53.957/53.978 2.124/2.125	58.999/59.017 2.323/2.324	24.94 0.982	2.502 0.0985	0.0406/0.1041 0.0016/0.0041			
42.959/42.972 1.691/1.692	45.999/ 46.025 1.811/ 1.812	14.99 0.590	1.499 0.0590	0.0279/0.0990 0.0011/0.0039		1 Pieza	
41.958/41.974 1.652/1.653	44.999/45.024 1.772/1.773	14.99 0.590	1.499 0.0590	0.0279/0.0838 0.0011/0.0033		1 Pieza	

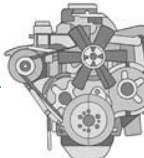
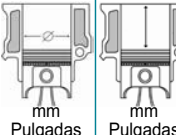

VOLKSWAGEN

MORESA!

CIL.	AÑO	MOTOR / APLICACIÓN			Diámetro del Cilindro Nominal Bore	Carrera Stroke	COJINETE, BUJE O ARANDELA	No. de Parte	Ubicación Location
CYL.	YEAR	ENGINE / APPLICATION			mm Pulgadas	mm Pulgadas	BEARING, BUSHING OR THURST WASHER	Part Number	
L4	1981-84	CR, CS, JK DIESEL (1.6L) (1588 cc)	76.50	86.38	3.012	3.401	COJINETE DE BIELA	4B1426 STD 010 020 030 040	TODOS
	1985	ME DIESEL (1.6L) (1588 cc)	79.50	80.00	3.130	3.150			
	1982-86	CY, MD, MF (1.6L) Turbocharged (1588 cc)	79.50	80.00	3.130	3.150	COJINETE DE BANCADA	5C1157 STD 010 020 030	1-2-4-5 (A, B)
	1992	(1.6L) SOHC 8 valve Turbocharged (1588 cc)	76.50	86.00	3.012	3.402			3 (C, D)
						BUJE	MO1726M STD	1	
								2	
L4	1981-85	SOHC (1.6L) (1588 cc)	79.50	80.00	3.130	3.150	COJINETE DE BIELA	4B1426 STD 010 020 030 040	TODOS
	1979-	SOHC (1.7L) (1716 cc) Iltis Jeep, Rabbit, Dasher, Caddy	79.50	86.40	3.130	3.402			
	1983-89	(1.8L) SOHC JH, JN (1781 cc) Golf, Caddy, Jetta, Passat, Santana, Sirocco, Vento, Bora, Sharan, Atlantic, Corsar, Caribe	81.00	86.40	3.189	3.402	COJINETE DE BANCADA	5C1157 STD 010 020 030	1-2-4-5 (A, B)
	1986-89	(1.8L) DOHC PL (1781 cc) Golf, Caddy, Jetta, Passat, Santana, Sirocco, Vento, Bora, Sharan, Atlantic, Corsar, Caribe	81.00	86.40	3.189	3.402			3 (C, D)
	1990-92	2H, ABG, HT, PF, PG, RD, RV, UM (1.8L) Supercharged (1781 cc) Golf, Caddy, Jetta, Passat, Santana, Sirocco, Vento, Bora, Sharan	81.00	86.40	3.189	3.402	BUJE	MO1726M STD	1
						2			

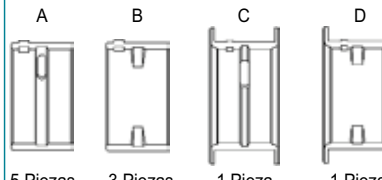

Línea Line
3

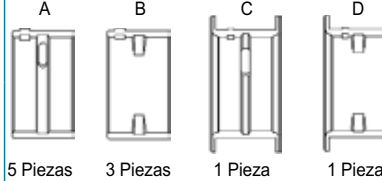
4

Diámetro Estándar del Muñón Standard Shaft Diameter	Diámetro Total del Alojamiento Housing Bore	Ancho del Cojinete Width Bearing	Espesor Máximo de Pared Max Wall Thickness	Claro de Lubricación Oil Clearance	Torque Torque	Imagen del Cojinete / Arandela Image of the Bearing and Thrust Washer
mm Pulgadas	mm Pulgadas	mm Pulgadas	mm Pulgadas	mm Pulgadas	N.m Lbs.Ft	
47.757/47.777 1.880/1.881	50.599/50.620 1.992/1.993	19.00 0.748	1.405 0.0553	0.0228/0.0812 0.0009/0.0032	30 N.m + 90° 22 Lbs. Ft + 90°	 8 Piezas
53.957/53.978 2.124/2.125	58.999/59.017 2.323/2.324	18.49 0.728	2.502 0.0985	0.0406/0.1041 0.0016/0.0041	64 a 68 N.m	 5 Piezas 3 Piezas 1 Pieza 1 Pieza
53.957/53.978 2.124/2.125	58.999/59.017 2.323/2.324	24.94 0.982	2.502 0.0985	0.0406/0.1041 0.0016/0.0041	47 a 50 Lbs.Ft	
42.959/42.972 1.691/1.692	45.999/46.025 1.811/1.812	14.99 0.590	1.499 0.0590	0.0279/0.0990 0.0011/0.0039		1 Pieza
41.958/41.974 1.652/1.653	44.999/45.024 1.772/1.773	14.99 0.590	1.499 0.0590	0.0279/0.0838 0.0011/0.0033		1 Pieza
47.757/47.777 1.880/1.881	50.599/50.620 1.992/1.993	19.00 0.748	1.405 0.0553	0.0228/0.0812 0.0009/0.0032	30 N.m + 90° 22 Lbs.Ft + 90°	 8 Piezas
53.957/53.978 2.124/2.125	58.999/59.017 2.323/2.324	18.49 0.728	2.502 0.0985	0.0406/0.1041 0.0016/0.0041	64 a 68 N.m	 5 Piezas 3 Piezas 1 Pieza 1 Pieza
53.957/53.978 2.124/2.125	58.999/59.017 2.323/2.324	24.94 0.982	2.502 0.0985	0.0406/0.1041 0.0016/0.0041	47 a 50 Lbs.Ft	
42.959/42.972 1.691/1.692	45.999/46.025 1.811/1.812	14.99 0.590	1.499 0.0590	0.0279/0.0990 0.0011/0.0039		1 Pieza
41.958/41.974 1.652/1.653	44.999/45.024 1.772/1.773	14.99 0.590	1.499 0.0590	0.0279/0.0838 0.0011/0.0033		1 Pieza

VOLKSWAGEN

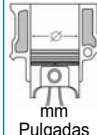
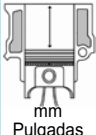

MORESA

CIL.	AÑO	MOTOR / APLICACIÓN		Diámetro del Cilindro Nominal Bore	Carrera Stroke	COJINETE, BUJE O ARANDELA	No. de Parte	Ubicación
				 mm Pulgadas	 mm Pulgadas	BEARING, BUSHING OR THURST WASHER		
5	L4	1982- 1800 (1.8L) A, G, J series K, P, R series (1781 cc) Golf, Cabrio, Beetle, Passat	81.00 3.190	86.40 3.402	COJINETE DE BIELA Sin barrenos, para diámetro de muñón 46 mm	4B1017 STD 010 020 030 040 050	TODOS	
	1990- 2000 (2.0L) A, KR, 2E, 9A series (1984 cc) Golf, Cabrio, Beetle, Passat	82.50 3.254	92.80 3.654	COJINETE DE BANCADA				5C1157 STD 010 020 030
6	L4	1990-94 9A DOHC (2.0L) (1984 cc) Cabrio, Golf, Jetta, Passat	82.50 3.248	92.80 3.654	COJINETE DE BIELA	4B1426 STD 010 020 030 040	TODOS	
	1993-98 ABA (2.0L) SOHC (1984 cc) Cabrio, Golf, Jetta, Passat	82.50 3.248	92.80 3.654	COJINETE DE BANCADA				5C1157 STD 010 020 030

Diámetro Estándar del Muñón Standard Shaft Diameter	Diámetro Total del Alojamiento Housing Bore	Ancho del Cojinete Width Bearing	Espesor Máximo de Pared Max Wall Thickness	Claro de Lubricación Oil Clearance	Torque Torque	Imagen del Cojinete / Arandela Image of the Bearing and Thrust Washer
45.938/45.959 1.809/1.809	48.999/49.014 1.929/1.930	19.00 0.748	1.506 0.0593	0.0406/0.1016 0.0016/0.0040	45 N.m 33 Lbs.Ft	 8 Piezas
53.957/53.978 2.124/2.125	58.999/59.017 2.323/2.324	18.49 0.728	2.502 0.0985	0.0406/0.1041 0.0016/0.0041	64 a 68 N.m	 5 Piezas 3 Piezas 1 Pieza 1 Pieza
53.957/53.978 2.124/2.125	58.999/59.017 2.323/2.324	24.94 0.982	2.502 0.0985	0.0406/0.1041 0.0016/0.0041	47 a 50 Lbs.Ft	
47.757/47.777 1.880/1.881	50.599/50.620 1.992/1.993	19.00 0.748	1.405 0.0553	0.0228/0.0812 0.0009/0.0032	30 N.m + 90° 22 Lbs.Ft + 90°	 8 Piezas
53.957/53.978 2.124/2.125	58.999/59.017 2.323/2.324	18.49 0.728	2.502 0.0985	0.0406/0.1041 0.0016/0.0041	64 a 68 N.m	 5 Piezas 3 Piezas 1 Pieza 1 Pieza
53.957/53.978 2.124/2.125	58.999/59.017 2.323/2.324	24.94 0.982	2.502 0.0985	0.0406/0.1041 0.0016/0.0041	47 a 50 Lbs.Ft	



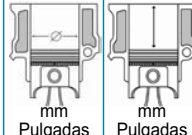
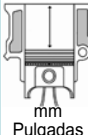



VOLKSWAGEN

MORESA!

CIL.	AÑO	MOTOR / APLICACIÓN		Diámetro del Cilindro Nominal Bore	Carrera Stroke	COJINETE, BUJE O ARANDELA	No. de Parte	Ubicación Location
CYL.	YEAR	ENGINE / APPLICATION		 mm Pulgadas	 mm Pulgadas	BEARING, BUSHING OR THURST WASHER	Part Number	
L5	2001-05	2500 (2.5L) AAF,ACU,AET,AEU (2459 cc) Caravelle, Transporter T4, Eurovan, Eurocarga, Eropasaje	81.00 3.189	95.50 3.760	COJINETE DE BIELA	5B1426 STD 010 020	TODOS	
					COJINETE DE BANCADA	6C1434 STD 010 020	1-2-4-5-6 (A, B)	
							3 (C, D)	
V6	1996-07	2800 (2.8L) AAA, AES (2792 cc) Golf, Passat, Bora VR6	81.00 3.189	90.29 3.555	COJINETE DE BIELA	6B1824 STD 010 020	TODOS	
					COJINETE DE BANCADA	7C2229 STD 010 020	1-2-3-4-5-6-7 (A, B)	

Línea Line
7

8

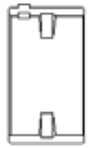
Diámetro Estándar del Muñón Standard Shaft Diameter	Diámetro Total del Alojamiento Housing Bore	Ancho del Cojinete Width Bearing	Espesor Máximo de Pared Max Wall Thickness	Claro de Lubricación Oil Clearance	Torque	Imagen del Cojinete / Arandela Image of the Bearing and Thrust Washer
mm Pulgadas	mm Pulgadas	mm Pulgadas	mm Pulgadas	mm Pulgadas	N.m Lbs.Ft	
47.757/47.777 1.880/1.881	50.599/50.620 1.992/1.993	19.00 0.748	1.405 0.0553	0.0228/0.0812 0.0009/0.0032	30 N.m + 90° 22 Lbs.Ft + 90°	 10 Piezas
63.000/63.017 2.282/2.283	63.000/63.017 2.480/2.481	18.50 0.728	2.502 0.0985		33 + 65 N.m	   
57.958/57.978 2.282/2.283	63.000/63.017 2.480/2.481	24.93 0.982	2.502 0.0985		24 + 48 Lbs.Ft	5 Piezas 5 Piezas 1 Pieza 1 Pieza
53.957/53.978 2.124/2.125	56.799/56.820 2.236/2.237	17.00 0.669	1.407 0.0554	0.0203/0.0736 0.0008/0.0029	30 N.m + 90° 22 Lbs. Ft + 90°	 12 Piezas
59.959/59.977 2.361/2.361	65.001/65.009 2.559/2.559	17.00 0.669	2.499 0.0984	0.020370.0762 0.0008/0.0030	Paso 1 60 N.m + 90° 44 Lbs.Ft + 90° Paso 2 24 N.m 18 Lbs.Ft	  7 Piezas 7 Piezas

No. de Parte	Armadora	CIL.	MOTOR / APLICACIÓN	AÑO	LINEA
Part Number	Manufacturer	CYL.	ENGINE / APPLICATION	YEAR	LINE

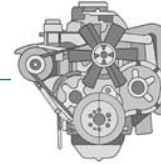

4B583 STD 010 020 030	FORD	L4	140 (2.3L) HSC OHV	1984-85	9
			140 (2.3L) HSC OHV	1984-94	9
			153 (2.5L) HSC OHV	1986-91	9

4B610 STD 010 020 030 040	CHRYSLER	L4	151 (2.5L) Pontiac Engine OHV	1980-83	10
	GM	L4	151 (2.5L) Pontiac OHV	1977-84	11
			151 (2.5L) Pontiac OHV Vin "R", "2"	1985-92	11
			151 (2.5L) Pontiac OHV Vin "A", "E"	1985-93	11
	VAM	L4	151 (2.5L) Pontiac Engine	1980-83	2

4B722 STD 010 020 030 040	RENAULT	L4	688/689/C1C (1.0L)	1963-66	1
			688/12/10, 688688.02, 688.01, 688.02/06/10/11, 688.09 (1.1L)	1965-66	1
			CIE 715 (1.1L)	1964-69	1
			CIE,750/G750 (1.1L)	1964-69	1
			810/25/26/29/03 (1.3L)	1969-79	1
			C1J,C2J,C3J,847 (1.4L)		1
			847 700/701,C1J (1.4L)		1
			CIJ 760/764/782 (1.4L) Turbocharged		1
			CIJ,C2J,C3J (1.3L)		1
			840-25 (1.3L)		1

4B745 STD 010 020 030 040 050 060	GM	L4	112 (1.8L) Chevrolet OHV	1982	6
			121 (2.0L) OHV LL8 Type 1	1987-89	6
			121 (2.0L) OHV Types B,P	1983-86	6
			121 (2.0L) OHV Type Y	1983-84	6
			122 (2.0L) Chevrolet (Cosworth) DOHC 16 valve	1975-77	6
			140 (2.3L) Chevrolet SOHC 8 valve	1971-77	6
			153 (2.5L) Chevrolet OHV	1962-70	6
			121 (2.0L) OHV LL8	1987-89	7
			134 (2.2L) OHV Types G,4	1990-97	7

NÚMERO BIELA

MORESA!

No. de Parte	Armadora	CIL.	MOTOR / APLICACIÓN	AÑO	LINEA
Part Number	Manufacturer	CYL.	ENGINE / APPLICATION	YEAR	LINE
4B780 STD 010 020 030 040 050 060	VW	4	1200 (1.2L) 112,113,126	1966-04	1
			1300 (1.3L)	1966-04	1
			1500 (1.5L) 311,341	1966-04	1
			1600 (1.6L) 122,126,211,311	1966-04	1
4B960 STD 010 020 030 040	CHRYSLER	L4	150 (2.5L) Jeep OHV	1983-02	8
	VAM	L4	150 (2.5L)	1983-88	1
4B966 STD 010 020 030	NISSAN	L4	L16 (1.6L)	1967-89	4
			L18 (1.8L)	1970-81	4
			L20B (2.0L) SOHC 8 valve	1974-80	9
			LD20 (2.0L)	1978-91	9
			Z20, Z20E, Z20S (2.0L) SOHC 8 valve	1975-86	9
			Z22, Z22E (2.2L) SOHC 8 valve	1982-88	9
4B967 STD 010 020 030 040 050 060	NISSAN	L4	E1 (1.2L)	1961-66	2
			J (1.3L)	1965-69	2
			J13 (1.3L)	1969-75	2
			J15 (1.4L)	1970-79	2
			J16 (1.6L)	1972-85	2

No. de Parte	Armadora	CIL.	MOTOR / APLICACIÓN	AÑO	LINEA
Part Number	Manufacturer	CYL.	ENGINE / APPLICATION	YEAR	LINE
4B980 STD 010 020 030	NISSAN	L4	A12 (1.2L)	1970-82	1
			A12A (1.2L)	1978-81	1
			A13 (1.3L)	1976-81	1
			A13S (1.3L)	1976-81	1
			A14 (1.4L)	1974-84	1
			A15 (1.5L)	1980-91	1
4B984 STD 010 020 030	FORD	L4	122 (2.0L) SOHC 8 valve	1983-88	7
			140 (2.3L) SOHC 8 valve	1974-97	7
			140 (2.3L) Turbo SOHC 8 valve	1979-90	7
			153 (2.5L) SOHC 8 valve	1998-01	7
	MAZDA	L4	140 Ford SOHC 8 valve	1994-97	5
			153 Ford SOHC 8 valve	1998-01	5
4B1005 STD 010 020 030 040 050	RENAULT	L4	688/689/C1C (1.0L)	1963-66	1
			688/12/10, 688688.02, 688.01, 688.02/06/10/11, 688.09 (1.1L)	1965-66	1
			CIE 715 (1.1L)	1964-69	1
			CIE 715 (1.1L)	1964-69	1
			CIE,750/G750 (1.1L)	1964-69	1
			810/25/26/29/03 (1.3L)	1969-79	1
			C1J,C2J,C3J,847 (1.4L)		1
			847 700/701,C1J (1.4L)		1
			CIJ 760/764/782 (1.4L) Turbocharged		1
			CIJ,C2J,C3J (1.3L)		1
840-25 (1.3L)		1			
4B1017 STD 010 020 030 040 050 060	AUDI	L4	1500 (1.5L)	1972-	1
			1588 cc (1.6L)	1972-	1
			1600 (1.6L) ABB,ABM,ADA,ADP- AEH,DT,JU,PP,RN	1985 -	1
	VW	L4	EH, FX (1.5L)	1978-80	2
			CK DIESEL (1.5L)	1977-80	2
			FC, FG, XR, XS, XV, XW, XY, XZ (1.5L)	1974-75	2
			EE, EJ, FN, YG, YH, YK (1.6L)	1976-80	2
			1800 (1.8L) A, G, J series - K, P, R series -	1982-	5
			2000 (2.0L) A,KR,2E,9A series	1990-	5

NÚMERO BIELA

MORESA!

No. de Parte	Armadora	CIL.	MOTOR / APLICACIÓN	AÑO	LINEA
Part Number	Manufacturer	CYL.	ENGINE / APPLICATION	YEAR	LINE
4B1110 STD 010 020 030	FORD	L4	110 (1.8L) Mazda VB SOHC 8 valve	1972-78	3
			121 (2.0L) Mazda MB SOHC 8 valve	1979-82	3
	MAZDA	L4	VB (1.8L) SOHC 8 valve	1968-78	3
			MA (2.0L) SOHC 8 valve	1977-89	3
4B1120 STD 010 020 030	CHRYSLER	L4	98 4G61 (1.6L) Mits. DOHC 16 valve	1990	3
			98 4G61T (1.6L) Mits. Turbo DOHC 16 valve	1989	3
			98 G32BT (1.6L) Mits. Turbo SOHC 8 valve	1971-84	3
			98 G32B (1.6L) Mits. SOHC 8 valve, Type K & Z	1971-84	3
			107 4G37 (1.8L) Mits. SOHC 8 valve	1989-92	3
			122 4G63 (2.0L) Mits. SOHC 8 valve	1983-92	3
			122 4G63 (2.0L) Mits. DOHC 16 valve	1989-94	3
			122 4G63T (2.0L) Mits. Turbo DOHC 16 valve	1989-94	3
			144 4G64 (2.4L) Mits. SOHC 8 valve	1989-94	3
			144 4G64 (2.4L) Mits. SOHC 8 valve	1993-94	3
	MITSUBISHI	L4	4G61 (1.6L) DOHC 16 valve	1991-92	3
			4G61T (1.6L) Turbo DOHC 16 valve	1989-90	3
			G32B (1.6L) Turbo SOHC 12 valve	1985-88	3
			G32B, (1.6L) 4G32		3
			4G37 (1.8L) SOHC 8 valve	1989-94	3
			4G63 (2.0L) SOHC 8 valve	1989-92	4
			4G63 (2.0L) DOHC 16 valve	1989-94	4
			4G63T (2.0L) Turbo DOHC 16 valve	1989-94	4
			G64B, 4G64 (2.4L)	1985-00	4
			G64B (2.4L) SOHC 12 valve	1985-88	4
			4G64 (2.4L) SOHC 8 valve	1989-96	4
			4G64 (2.4L) SOHC 16 valve	1993-05	4
4G64 (2.4L) DOHC 16 valve	1994	4			

MORESA

NÚMERO BIELA

No. de Parte	Armadora	CIL.	MOTOR / APLICACIÓN	AÑO	LINEA
Part Number	Manufacturer	CYL.	ENGINE / APPLICATION	YEAR	LINE
4B1202 STD 010 020 030 040	RENAULT	L4	697.01 (1.5L)	1966-70	2
			807 03/04/05/06 (1.6L)	1969-85	2
			807 10/11 (1.6L)		2
			807 12/13/20 (1.6L)		2
			821 (9CV) (1.6L)		2
			807 A 7 27 (1.6L)		2
			843/841 (1.6L)	1973-77	2
			841/841 (1.6L) (A2M)		2
841-99 (1.6L) A1M		2			
4B1216 STD 010 020 030 040	GM	L4	85 (1.4L) Chevrolet SOHC 8 valve	1976-77	2
			98 (1.6L) Chevrolet SOHC 8 valve	1976-87	2
4B1218 STD 010 020 030	TOYOTA	L4	8RC (1.9L) SOHC	1969-71	3
			18RC (2.0L) SOHC	1972-74	3
			20R (2.2L) SOHC 8 valve	1974-82	5
			22R (2.4L) SOHC 8 valve	1980-90	5
			22RE (2.4L) SOHC 8 valve	1989-95	5
			22REC (2.4L) SOHC 8 valve	1983-88	5
4B1220 STD 010 020 030 040	CHRYSLER	L4	122 (2.0L) G52B Mits. SOHC 8 valve	1974-82	5
			156 (2.6L) G54B Mits. SOHC 8 valve, Type F	1978-87	5
			156 (2.6L) G54B Mits. SOHC 8 valve, Type W	1979-90	5
			156 (2.6L) G54B Mits. Turbo SOHC 8 valve	1984-90	5
	MITSUBISHI	L4	4G54 (2.6L)	1983-89	5
			G54B, 4G54 (2.6L) SOHC 12 valve	1983-89	5
G54B (2.6L) Turbo SOHC 12 valve	1983-89	5			
4B1222 STD 010 020 030	HONDA	L4	EB1 (1.2L) SOHC 8 valve	1973	1
			EB2,EB3 (1.2L) SOHC 8 valve	1974-79	1
			EE (1.2L) SOHC 8 valve	1975-79	1
			EJ1 (1.3L) SOHC 8 valve	1980-83	1
			EN (1.3L) SOHC 8 valve	1979-83	1

NÚMERO BIELA

MORESA!

No. de Parte	Armadora	CIL.	MOTOR / APLICACIÓN	AÑO	LINEA
Part Number	Manufacturer	CYL.	ENGINE / APPLICATION	YEAR	LINE
4B1223 STD 010 020 030	HONDA	L4	ED1,ED2,ED3,ED4 (1.5L) SOHC 8 valve	1974-78	3
			EM1 (1.5L) SOHC 8 valve	1979-83	3
			EF1 (1.6L) SOHC 8 valve	1976-86	3
			EP (1.6L) SOHC 8 valve	1980-86	3
			EK,EK1 (1.8L) SOHC 8 valve	1978-83	3
4B1250 STD 010 020	MAZDA	L4	UB (1.5L)	1970-73	2
			NA (1.6L) SOHC 8 valve	1970-77	2
			VC (1.8L)	1973-86	2
4B1269 STD 010 020 030	CHRYSLER	L4	135 (2.2L) SOHC 8 valve	1981-94	6
			135 (2.2L) DOHC 8 valve	1988-91	6
			135 (2.2L) Turbo SOHC 8 valve	1984-90	6
			135 (2.2L) Turbo DOHC 16 valve	1988-93	6
			153 (2.5L) SOHC 8 valve	1986-95	9
			153 (2.5L) Turbo SOHC 8 valve	1989-92	9
4B1270 STD 010 020 030 040	TOYOTA	L4	2TC (1.6L) OHV	1971-79	2
			12T (1.6L)	1976-84	2
			3TC (1.8L) OHV, 3T-G	1980-82	2
			13T (1.8L)	1977-82	2
			4T-G (1.8L)	1982-84	2
4B1278 STD 010 020 030 040	CHRYSLER	L4	86 G12B (1.4L) Mits. SOHC 8 valve	1979-84	2
			92 4G15 (1.4L) Mits. SOHC 8 valve, carb. 4G15	1985-90	2
			92 4G15 (1.4L) Mits. SOHC 8 valve, F.I.	1987-90	2
			92 4G15 (1.4L) Mits. SOHC 12 valve	1991-94	2
	MITSUBISHI	L4	G11B, 4G11 (1.3L)	1977-85	1
			G13B, 4G13 (1.3L)	1983-	1
			G12B, 4G12 (1.4L)	1976-88	1
			G15B, 4G15, G4AJ (1.5L) SOHC 8 valve	1983-90	1
			4G15 (1.5L) SOHC 12 valve	1991-02	1
			G4AJ (1.5L) 8 valve	1987-89	1

No. de Parte	Armadora	CIL.	MOTOR / APLICACIÓN	AÑO	LINEA
Part Number	Manufacturer	CYL.	ENGINE / APPLICATION	YEAR	LINE
4B1279 STD 010 020 030	FORD	L4	81 (1.3L) Mazda SOHC 8 valve	1988-97	2
			98 (1.6L) Mazda SOHC 8 valve	1987-89	2
			98 (1.6L) Mazda DOHC 16 valve	1990-94	2
			98 (1.6L) Mazda Turbo DOHC 16 valve	1990-94	2
			112 (1.8L) Mazda DOHC 16 valve	1991-96	2
	MAZDA	L4	TC (1.3L) SOHC	1978	1
			UC (1.4L) SOHC	1979-80	1
E5 (1.5L) SOHC			1981-85	1	
4B1326 STD 020 030 040	NISSAN	L4	E15, E15S (1.5L) SOHC 8 valve	1981-91	3
			E15T (1.5L) Turbo SOHC 8 valve	1983-84	3
			E16 (1.6L) SOHC 8 valve	1983-86	3
			E16I, E16S (1.6L) SOHC 8 valve	1986-88	3
4B1361 STD 010 020 030	GM	L4	97 (1.6L) Toyota SOHC 8 valve	1985-89	3
			97 (1.6L) Toyota SOHC 16 valve	1988-89	3
	TOYOTA	L4	3AC (1.5L) SOHC 8 valve	1979-90	1
			1AC (1.5L) SOHC 8 valve	1978-80	1
			5A (1.5L)	1987-	1
			4ALC (1.6L) SOHC 8 valve	1983-88	1
			4AC (1.6L) SOHC 8 valve	1983-87	1
			4AF (1.6L) DOHC 16 valve	1988-89	1
			4AFE (1.6L) DOHC 16 valve	1989-97	1
			4AGEC (1.6L) DOHC 16 valve	1985-87	1
			4AGELC (1.6L) DOHC 16 valve	1985-89	1
			4AGZE (1.6L) Supercharged DOHC 16 valve	1987-89	1
			4AGE (1.6L) DOHC 16 valve	1988-91	1
4B1362 STD 010 020 030 040	FORD	L4	122 (2.0L) Mazda Diesel SOHC 8 valve	1984-87	6
			133 (2.2L) Mazda SOHC 12 valve	1989-92	8
			133 (2.2L) Mazda Turbo SOHC 12 valve	1989-92	8
	MAZDA	L4	FE (2.0L) SOHC 8 valve	1982-87	4
			FE (2.0L) Turbo SOHC 8 valve	1986-87	4
			FEH1, FEH5 (2.0L)	1983-87	4
			F2 (2.2L) SOHC 8 valve	1987-93	4
			F2 (2.2L) SOHC 12 valve	1987-93	4
F2 (2.2L) Turbo SOHC 12 valve	1988-92	4			

NÚMERO BIELA

MORESA!

No. de Parte	Armadora	CIL.	MOTOR / APLICACIÓN	AÑO	LINEA
Part Number	Manufacturer	CYL.	ENGINE / APPLICATION	YEAR	LINE
4B1377 STD 010 020 030	GM	L4	111 (1.8L) Isuzu SOHC 8 valve	1972-82	5
			119 (1.9L) Isuzu SOHC 8 valve LR1	1982-85	5
	ISUZU	L4	4ZC1 (2.0L) SOHC Turbo	1985-89	2
			4ZD1 (2.2L) SOHC 8 valve	1986-95	2
			G200 (2.0L)	1988-89	3
			G200 (2.0L) SOHC 8 valve	1988-89	3
4B1380 STD 010 020 030 040	FORD	L4	116 (1.9L) SOHC 8 valve	1985-96	4
			121 (2.0L) SOHC 8 valve	1997-04	4
4B1383 STD 010 020 030 040	FORD	L4	140 (2.3L) HSC OHV	1984-85	9
			140 (2.3L) HSC OHV	1984-94	9
			153 (2.5L) HSC OHV	1986-91	9
4B1388 STD 010 020	GM	L4	138 (2.3L) Oldsmobile SOHC 8 valve	1992-94	9
			138 (2.3L) Oldsmobile DOHC 16 valve	1987-96	9
4B1401 STD 010 020 030	SUZUKI	L4	G13BA (1.3L) SOHC	1989-98	1
			G13A (1.3L) SOHC	1986-89	1

MORESA

NÚMERO BIELA

No. de Parte	Armadora	CIL.	MOTOR / APLICACIÓN	AÑO	LINEA
Part Number	Manufacturer	CYL.	ENGINE / APPLICATION	YEAR	LINE
4B1426 STD 010 020 030 040	AUDI	L4	1800 (1.8L) ADR/AEB/AGN/AGU- DR/DS/DZ -	1982-	2
			JN/JV/JW/ - NE/NP/PH/PM/PV - RS/RU/SH/4B		2
			2000 (2.0L) AAD,AAE,ABK,ABT- ADW,3A,6A	1986-	2
	VW	L4	CR, CS, JK DIESEL (1.6L)	1981-84	3
			ME DIESEL (1.6L)	1985	3
			CY, MD, MF (1.6L) Turbocharged	1982-86	3
			(1.6L) SOHC 8 valve Turbocharged	1992	3
			SOHC (1.6L)	1981-85	4
			SOHC (1.7L)	1979-	4
			(1.8L) SOHC JH, JN	1983-89	4
			(1.8L) DOHC PL	1986-89	4
			2H, ABG, HT, PF, PG, RD, RV, UM (1.8L) Supercharged	1990-92	4
			9A DOHC (2.0L)	1990-94	6
ABA (2.0L) SOHC	1993-98	6			
4B1451 STD 010 020	GM	L4	1.4 L	1994-03	1
			1.6 L	1996-08	1
			C 16 NZ/E 16 SE /X 16 SZR (1.6L)		1
			X 16 XE/XEL (1.6L)		1
4B1589 STD 010 020 030	NISSAN	L4	KA24DE (2.4L) DOHC 16 valve	1999-08	11
			KA24E (2.4L) SOHC 12 valve	1989-98	11
4B1590 STD 010 020 030 040	NISSAN	L4	E15, E15S (1.5L) SOHC 8 valve	1981-91	3
			E15T (1.5L) Turbo SOHC 8 valve	1983-84	3
			E16 (1.6L) SOHC 8 valve	1983-86	3
			E16I, E16S (1.6L) SOHC 8 valve	1986-88	3
			GA16DE (1.6L) DOHC 16 valve	1991-99	5
			GA16I (1.6L) SOHC 12 valve	1989-90	5
QG18DE (1.8L) DOHC 16 valve	2000-05	8			

NÚMERO BIELA

MORESA!

No. de Parte	Armadora	CIL.	MOTOR / APLICACIÓN	AÑO	LINEA
Part Number	Manufacturer	CYL.	ENGINE / APPLICATION	YEAR	LINE
4B1629 STD 010 020 030	NISSAN	L4	SR20DE (2.0L) DOHC 16 valve	1991-02	10
4B1635 STD 010 020 030	CHRYSLER	L4	122 (2.0L) SOHC 16 valve	1995-06	4
			122 (2.0L) DOHC 16 valve	1995-99	4
4B1647 STD 010 020	GM	L4	146 (2.4L) DOHC Oldsmobile, LD9, 16 valve	1996-02	10
4B1827 STD 010 020	GM	L4	134 (2.2L) L61 DOHC ECOTEC	2000-05	8
			134 (2.2L) L42 DOHC ECOTEC	2003	8
			2.2L (2.2L) DOHC ECOTEC 16 valve	2001-03	8
4B4121 STD 010 020 030	FORD	L4	Zetec NGA (2.0L) DOHC 16 Valve	1996-	5
			ZH20 Zetec E		
			122 Zetec (2.0L) DOHC 16 valve	1996-04	5
4B4565 STD 010 020 030 040	CHRYSLER	L4	148 (2.4L) DOHC, 16 Valve	1995-04	7
			148 (2.4L) Turbo DOHC 16 valve	2003-04	7

MORESA

NÚMERO BIELA

No. de Parte	Armadora	CIL.	MOTOR / APLICACIÓN	AÑO	LINEA
Part Number	Manufacturer	CYL.	ENGINE / APPLICATION	YEAR	LINE
4B7000 STD 25MM 50MM	CHRYSLER	L4	G4HC (1.0L)	2000-05	1
			1086cc (1.1L) SOHC 12V	2000-05	1
	HYUNDAI	L4	G4HC (1.0L)	2000-04	1
			1086cc (1.1L) SOHC 12V	2004-08	1
4B7001 STD 25MM 50MM	FORD	L4	1.3 L, (1.3L) HSC	1998-02	1
			1.4 L, (1.4L) HSC	1998-04	1
			1.6 L (1.6L) HSC, Zetec Rocam ZL	1998-04	1
4B7002 STD 010 020	NISSAN	L4	K4M (1.6L)	1999-08	6
	RENAULT	L4	K4M (1.6L)	1999-08	3
4BX832 STD 010 020 030	NISSAN	L4	J18 (1.8L)	1981-93	7
6B416 STD 010 020 030 040	GM	L6	235 (3.8L) Chevrolet OHV	1953-62	22
			261 (4.2L) Chevrolet OHV	1954-62	22
			261 (4.3L) Chevrolet OHV	1954-62	22
6B583 STD 010 020 030 040	FORD	L6	144 (2.4L) OHV	1960-64	10
			170 (2.8L) OHV	1961-72	10
			200 (3.3L) OHV	1963-64	10
			200 (3.3L) OHV	1965-83	16
			250 (4.1L) OHV	1969-80	20

NÚMERO BIELA

MORESA!

No. de Parte	Armadora	CIL.	MOTOR / APLICACIÓN	AÑO	LINEA
Part Number	Manufacturer	CYL.	ENGINE / APPLICATION	YEAR	LINE
6B606 STD 010 020 030 040	CHRYSLER	L6	170 (2.8L) OHV	1960-71	13
			198 (3.2L) OHV	1969-76	13
			225 (3.7L) H225, HA225, HB225, HC225	1960-87	19
6B610 STD 010 020	CHRYSLER	V6	225 (3.7L) Buick engine OHV	1965-71	18
	GM	V6	196 (3.2L) Buick OHV	1964-77	16
			252 (4.1L) Buick OHV	1980-84	16
			225 (3.7L) Buick OHV	1964-77	20
			231 (3.8L) Buick OHV, Vin "C", "L", Series I	1988-95	21
			231 (3.8L) Buick OHV, Vin "K", Series II	1995-04	21
			231 (3.8L) Buick Supercharged OHV, Vin "1"	1991-04	21
			231 (3.8L) Buick OHV, Exc. 3800 Series I and II	1975-88	21
			231 (3.8L) Buick OHV, Vin "C", "L", Series I	1988-95	21
			231 (3.8L) Buick OHV Type K 3800 Series II	1995-05	21
			231 (3.8L) Buick Supercharged OHV, Vin "1"	1991-05	21
231 (3.8L) Type 1 Supercharged 3800 Series II	1996-99	21			
6B663 STD 010 020 030 040	GM	L6	292 (4.8L) Chevrolet OHV Vin "T"	1963-90	26
6B699 STD 010 020 030 040	FORD	L6	240 (3.9L) OHV	1965-74	18
			300 (4.9L) OHV	1965-96	22

No. de Parte	Armadora	CIL.	MOTOR / APLICACIÓN	AÑO	LINEA
Part Number	Manufacturer	CYL.	ENGINE / APPLICATION	YEAR	LINE
6B723 STD 010 020 030 040	FORD	V6	159 (2.6L) OHV	1972-73	12
			171 (2.8L) OHV	1974-79	13
			171 (2.8L) OHV	1983-86	13
			171 (2.8L) OHV	1983-86	13
			244 (4.0L) OHV	1990-00	19
			244 (4.0L) SOHC 12 valve	1997-01	19
			244 (4.0L) Flex Fuel SOHC 12 valve	2002-03	19
6B745 STD 010 020 030 040 050 060	GM	L6	194 (3.2L) Chevrolet OHV	1962-67	15
			215 (3.5L) Pontiac OHV	1964-65	15
			230 (3.8L) Chevrolet OHV	1962-70	15
			230 (3.8L) Pontiac SOHC 12 valve	1966-67	15
			250 (4.1L) Pontiac SOHC 12 valve	1968-69	23
			250 (4.1L) Chevrolet OHV	1966-84	23
			250 (4.1L) Chevrolet OHV	1994-98	23
			6B960 STD 010 020 030 040 050 060	CHRYSLER	L6
242 (4.0L) Jeep OHV	1987-02	22			
258 (4.2L) AMC OHV	1971-90	22			
258 (4.2L) AMC OHV	1987-90	22			
258 (4.2L) AMC OHV	1991-02	22			
VAM	L6	199 (3.3L)		1965-70	3
		232 (3.8L)		1964-79	3
		258 (4.2L)		1971-88	3
6B966 STD 010 020 030	NISSAN	L6		L24 (2.4L)	1971-87
			L26 (2.6L)	1971-78	12
			L28 (2.8L)	1975-83	12
			LD28 (2.8L)	1979-86	12

NÚMERO BIELA

MORESA!

No. de Parte	Armadora	CIL.	MOTOR / APLICACIÓN	AÑO	LINEA
Part Number	Manufacturer	CYL.	ENGINE / APPLICATION	YEAR	LINE
6B1214 STD 010 020 030 040 050	CHRYSLER	L6	170 (2.8L) OHV	1960-71	13
			198 (3.2L) OHV	1969-76	13
			225 (3.7L) OHV	1960-87	20
6B1227 STD 010 020 030	GM	V6	200 (3.3L) Chevrolet OHV	1978-79	17
			229 (3.8L) Chevrolet OHV	1980-84	17
6B1227 STD 010 020 030	GM	V6	200 (3.3L) Chevrolet OHV	1978-79	17
			229 (3.8L) Chevrolet OHV (K)	1980-84	17
6B1228 STD 010 020 030 040	GM	V6	181 (3.0L) Buick OHV	1982-88	14
			231 (3.8L) Buick Turbo OHV	1978-89	14
			204 (3.3L) Buick OHV	1988-93	18
			231 (3.8L) Buick OHV, Vin "C", "L", Series I	1988-95	21
			231 (3.8L) Buick OHV, Vin "K", Series II	1995-04	21
			231 (3.8L) Buick Supercharged OHV, Vin "1"	1991-04	21
			231 (3.8L) Buick OHV, Exc. 3800 Series I and II	1975-88	21
			231 (3.8L) Buick OHV, Vin "C", "L", Series I	1988-95	21
			231 (3.8L) Buick OHV Type K 3800 Series II	1995-05	21
			231 (3.8L) Buick Supercharged OHV, Vin "1"	1991-05	21
231 (3.8L) Type 1 Supercharged 3800 Series II	1996-99	21			

No. de Parte	Armadora	CIL.	MOTOR / APLICACIÓN	AÑO	LINEA
Part Number	Manufacturer	CYL.	ENGINE / APPLICATION	YEAR	LINE
6B1238 STD 010 020 030 040	CHRYSLER	V6	173 (2.8L) Chevrolet OHV, First Design	1980-85	14
	GM	V6	173 (2.8L) Chevrolet OHV, First Design	1980-85	12
			173 (2.8L) Chevrolet OHV, Second Design	1985-93	12
			173 (2.8L) Chevrolet LPG	1987-89	13
			173 (2.8L) Chevrolet Meth	1987-89	13
			191 (3.1L) Types D,M,T,W,V6	1988-05	13
			191 (3.1L) Chevrolet Turbo OHV	1989-90	13
			207 (3.4L) OHV Type S	1993-03	13
			207 (3.4L) DOHC 24 valve Type X	1991-97	13
			207 (3.4L) OHV Type S	1993-03	19
			207 (3.4L) DOHC 24 valve Type X	1991-97	19
	L6	250 (4.1L) Pontiac SOHC 12 valve	1968-69	23	
		250 (4.1L) Chevrolet OHV	1966-84	23	
250 (4.1L) Chevrolet OHV		1994-98	23		
6B1283 STD 010 020 030 040	FORD	V6	232 (3.8L) OHV	1982-04	17
			232 (3.8L) Supercharged OHV	1989-95	17
			238 (3.9L) OHV	2004	17
6B1358 STD 010 020 030 040	GM	V6	262 (4.3L) Chevrolet exc. High Output, OHV	1985-06	25
			262 (4.3L) Chevrolet High Output OHV Vin "B" LU4	1990-91	25
			262 (4.3L) Chevrolet Turbo OHV Vin "Z" LB4	1991-93	25
6B1385 STD 010 020 030	FORD	V6	183 (3.0L) OHV exc. SHO eng.	1986-06	15

NÚMERO BIELA

MORESA!

No. de Parte	Armadora	CIL.	MOTOR / APLICACIÓN	AÑO	LINEA
Part Number	Manufacturer	CYL.	ENGINE / APPLICATION	YEAR	LINE
6B1387 STD 010 020 030	CHRYSLER	V6	239 (3.9L) OHV Dodge Truck V6 Engine	1987-03	23
6B1410 STD 010 020 030 040	CHRYSLER	V6	201 (3.3L) OHV	1990-06	16
			231 (3.8L) OHV	1991-06	16
			215 (3.5L) OHV Chrysler V6 Engine	1993-97	17
6B1411 STD 010 020 030	CHRYSLER	V6	153 (2.5L) 6G73 Mits. EEB SOHC 24 valve	1995-00	11
			181 (3.0L) 6G72 Mits. SOHC 12 valve	1987-00	15
			181 (3.0L) 6G72 Mits. DOHC 24 valve	1991-96	15
			181 (3.0L) 6G72 Mits. Turbo DOHC 24 valve	1991-96	15
			181 (3.0L) 6G72 DOHC (Nat. Asp.)	1991-99	15
	MITSUBISHI	V6	6G72 (3.0L)	1986-92	6
			6G72 (3.0L) SOHC 12 valve	1988-99	6
			6G72 (3.0L) SOHC 24 valve	1994-05	6
			6G72 (3.0L) DOHC 24 valve	1991-99	6
			6G72T (3.0L) Turbo DOHC 24 valve	1991-99	6
6B1443 STD 010 020 030	GM	V6	204 (3.3L) Buick OHV	1988-93	18
			231 (3.8L) Buick OHV, Vin "C", "L", Series I	1988-95	21
			231 (3.8L) Buick OHV, Vin "K", Series II	1995-04	21
			231 (3.8L) Buick Supercharged OHV, Vin "1"	1991-04	21
			231 (3.8L) Buick OHV, Exc. 3800 Series I and II	1975-88	21
			231 (3.8L) Buick OHV, Vin "C", "L", Series I	1988-95	21
			231 (3.8L) Buick OHV Type K 3800 Series II	1995-05	21
			231 (3.8L) Buick Supercharged OHV, Vin "1"	1991-05	21
231 (3.8L) Type 1 Supercharged 3800 Series II	1996-99	21			

MORESA

NÚMERO BIELA

No. de Parte	Armadora	CIL.	MOTOR / APLICACIÓN	AÑO	LINEA
Part Number	Manufacturer	CYL.	ENGINE / APPLICATION	YEAR	LINE
6B1591 STD 010 020 030 040	FORD	V6	181 (3.0L) Nissan SOHC 12 valve	1993-98	14
			199.8 (3.3L) Nissan SOHC 12 valve	1999-02	14
	NISSAN	V6	VG30 (3.0L)	1983-	13
			VG30D (3.0L)	1987-	13
			VG30 (3.0L) SOHC 12 valve	1984-89	13
			VG30E, VG30i (3.0L) SOHC 12 valve	1984-98	13
			VG30T (3.0L) Turbo SOHC 12 valve	1984-98	13
			VG30DE (3.0L) DOHC 24 valve	1984-98	13
			VG30DETT (3.0L) Twin Turbo DOHC 24 valve	1990-96	13
VG33E (3.3L) SOHC 12 valve	1996-04	13			
6B1667 STD 010 020 030 040	FORD	V6	232 (3.8L) OHV	1982-04	17
			232 (3.8L) Supercharged OHV	1989-95	17
			238 (3.9L) OHV	2004	17
			256 (4.2L) OHV	1997-06	21
6B1670 STD 25MM 50MM	CHRYSLER	V6	167 (2.7L) DOHC 24 valve	1998-05	12
6B1818 STD 25MM 50MM	CHRYSLER	V6	226 (3.7L) EKG SOHC 12 valve	2002-06	21
6B1824 STD 010 020	VW	V6	2800 (2.8L) AAA, AES	1996-07	8

NÚMERO BIELA

MORESA!

No. de Parte	Armadora	CIL.	MOTOR / APLICACIÓN	AÑO	LINEA
Part Number	Manufacturer	CYL.	ENGINE / APPLICATION	YEAR	LINE
6B6155 STD 010 020 030	FORD	V6	155 (2.5L) Duratec DOHC 24 valve	1995-02	11
			181 (3.0L) Duratec DOHC 24 valve	1996-06	11
8B461 STD 010 020 030 040	FORD	V8	239 (3.9L) OHV	1954-55	24
			256 (4.1L) OHV	1954-55	24
			272 (4.5L) OHV	1955-58	24
			292 (4.8L) OHV	1955-64	24
			312 (5.1L) OHV	1956-60	24
8B481 STD 010 020 030 040	CHRYSLER	V8	273 (4.5L) OHV	1964-69	24
			277 (4.6L) OHV	1956-57	24
			301 (4.9L) OHV	1957	24
			303 (5.0L) OHV	1956	24
			313 (5.1L) OHV	1957-58	24
			318 (5.2L) OHV	1957-73	24
			318 (5.2L) OHV	1974-03	24
			318 (5.2L) OHV	1993-98	24
			326 (5.3L) OHV	1959	24
			340 (5.7L) OHV	1968-73	26
			360 (5.9L) OHV	1971-03	29
			360 (5.9L) OHV	1974-01	29
			360 (5.9L) OHV	1971-73	29
			360 (5.9L) Chrysler OHV	1974-2001	29
360 (5.9L) OHV	1971-78	29			
360 (5.9L) OHV	1979-99	29			

MORESA

NÚMERO BIELA

No. de Parte	Armadora	CIL.	MOTOR / APLICACIÓN	AÑO	LINEA
Part Number	Manufacturer	CYL.	ENGINE / APPLICATION	YEAR	LINE

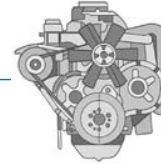

8B527 STD 010 020 030 040	CHRYSLER	V8	350 (5.7L) OHV	1958	28
			361 (5.9L) OHV	1958-77	28
			361.1 (5.9L) OHV	1966-67	28
			383 (6.3L) OHV	1961-71	28
			400 (6.6L) OHV	1972-80	28
			383 (6.3L) OHV	1959-60	30
			413 (6.8L) OHV	1959-77	30
			413 (6.8L) OHV HT413	1960-77	30
			426 (7.0L) OHV Wedge	1963-65	30
			426 (7.0L) HEMI	1964-71	30
			440 (7.2L) OHV	1966-80	30
440-3 (7.2L) OHV	1972-80	30			

8B610 STD 010 020	CHRYSLER	V8	350 (5.7L) Buick OHV	1968-71	27
	GM	V8	265 (4.3L) Pontiac OHV Vin "S"	1980-81	29
			301 (4.9L) Pontiac OHV	1977-81	29
			301 (4.9L) Pontiac Turbo OHV	1980-81	29
			350 (5.7L) Buick OHV Type B	1968-81	29
			300 (4.9L) Buick OHV	1964-67	32
			340 (5.6L) Buick OHV	1966-67	

8B634 STD 010 020 030 040	FORD	V8	221 (3.7L) OHV	1962-63	23
			255 (4.2L) OHV	1980-82	23
			260 (4.3L) OHV	1962-65	23
			289 (4.7L) OHV exc. Vin "K" and w/ A4 trans.	1965-68	23
			289 (4.7L) OHV w/ A4 trans	1963-64	23
			289 (4.7L) OHV w/ Vin "K"	1963-68	23
			302 (4.9L) OHV w/ Boss and Eliminator engs.	1969-71	23
			302 (5.0L) OHV exc. Boss and Eliminator engs.	1968-01	23
302 (5.0L) High Output OHV exc. Boss and Eliminator engs.	1982-95	23			

NÚMERO BIELA

MORESA!

No. de Parte	Armadora	CIL.	MOTOR / APLICACIÓN	AÑO	LINEA
Part Number	Manufacturer	CYL.	ENGINE / APPLICATION	YEAR	LINE
8B663 STD 010 020 030 040	GM	V8	262 (4.3L) Chevrolet OHV Vin "G"	1975-76	28
			265 (4.3L) Chevrolet L99 OHV Vin "W"	1994-96	28
			267 (4.4L) Chevrolet OHV Vin "J"	1979-82	28
			305 (5.0L) Chevrolet OHV	1976-99	28
			307 (5.0L) Chevrolet OHV	1968-73	28
			327 (5.4L) Chevrolet OHV Vin "L"	1968-69	28
			293 (4.8L) Chevrolet Vortec OHV Gen III	1999-06	31
			325 (5.3L) Chevrolet Vortec OHV Gen III	1999-06	31
			346 (5.7L) Chevrolet LS1 Vortec OHV Gen III	1997-04	31
			346 (5.7L) Chevrolet LS6 Vortec OHV Gen III	2001-06	31
			365 (6.0L) Chevrolet Vortec OHV Gen III	1999-06	31
			302 (4.9L) Chevrolet OHV	1967-69	33
			327 (5.4L) Chevrolet OHV	1962-69	33
			350 (5.7L) Chevrolet OHV, Inc. LT1, Exc. DOHC	1967-02	33
			348 (5.7L) Chevrolet OHV	1958-65	36
400 (6.6L) Chevrolet OHV	1970-80	38			
8B684 STD 010 020 030 040	GM	V8	260 (4.3L) Oldsmobile OHV	1975-82	27
			350 (5.7L) Oldsmobile OHV	1968-80	27
			307 (5.0L) Oldsmobile OHV	1980-90	34
			330 (5.4L) Oldsmobile OHV , Second Series	1964-67	35
			403 (6.6L) Oldsmobile OHV	1977-79	39
8B743 STD 010 020 030 040	GM	V8	348 (5.7L) Chevrolet OHV	1958-65	36
			366 (6.0L) Chevrolet OHV	1966-00	37
			396 (6.5L) Chevrolet OHV	1965-70	37
			402 (6.6L) Chevrolet OHV	1970-72	37
			427 (7.0L) Chevrolet OHV	1966-00	37
			454 (7.4L) Chevrolet OHV	1970-00	37
			502 (8.2L) Chevrolet Gen IV, V, VI OHV	1990-01	37
			496 (8.1L) Chevrolet Vortec OHV	2001-05	40

MORESA

NÚMERO BIELA

No. de Parte	Armadora	CIL.	MOTOR / APLICACIÓN	AÑO	LINEA
Part Number	Manufacturer	CYL.	ENGINE / APPLICATION	YEAR	LINE
8B745 STD 010 020 030 040	GM	V8	283 (4.6L) Chevrolet OHV	1957-67	30
			302 (4.9L) Chevrolet OHV	1967-69	33
			327 (5.4L) Chevrolet OHV	1962-69	33
			350 (5.7L) Chevrolet OHV, Inc. LT1, Exc. DOHC	1967-02	33
8B760 STD 010 020 030 040	FORD	V8	330 (5.4L) OHV	1964-78	27
			332 (5.4L) OHV	1958-59	27
			352 (5.7L) OHV	1964-67	27
			352 (5.8L) OHV	1958-63	27
			361 (5.9L) OHV	1964-78	27
			361 (5.9L) OHV	1958-59	27
			390 (6.4L) OHV	1961-63	27
			390 (6.4L) OHV	1964-76	27
			391 (6.4L) OHV	1964-78	27
			359 (5.9L) OHV	1973-78	30
			410 (6.7L) OHV	1966-67	30
			427 (7.0L) OHV	1968	30
428 (7.0L) OHV	1975-78	30			
428 (7.0L) OHV	1966-70	30			
8B818 STD 010 020 030 040	FORD	V8	370 (6.1L) OHV	1979-91	31
			429 (7.0L) OHV Truck	1979-98	31
			429 (7.0L) OHV Pass.	1968-73	31
			460 (7.5L) OHV	1968-98	31
8B831 STD 010 020 030 040 050 060	FORD	V8	335 (5.5L) MÉXICO	1969-86	28
			351W (5.8L)	1969-99	28

NÚMERO BIELA

MORESA!

No. de Parte	Armadora	CIL.	MOTOR / APLICACIÓN	AÑO	LINEA
Part Number	Manufacturer	CYL.	ENGINE / APPLICATION	YEAR	LINE
8B927 STD 010 020 030 040	FORD	V8	351M (5.8L) OHV	1975-82	29
			400 (6.6L) OHV	1971-82	29
8B960 STD 010 020 030 040	VAM	V8	290 (4.7L)	1966-69	4
			304 (5.0L)	1970-79	4
			343 (5.6L)	1967-69	4
			360 (5.9L)	1970-78	4
8B1442 STD 010 020 030 040	FORD	V8	281 (4.6L) SOHC 16 valve	1991-05	25
			281 (4.6L) SOHC CNG 16 valve	1995-03	25
			281 (4.6L) SOHC LPG 16 valve	1997-98	25
			281 (4.6L) DOHC 32 valve (Triton)	1993-04	25
			281 (4.6L) DOHC 32 valve Supercharged / Intercooled (Triton)	2003-04	25
			330 (5.4L) SOHC 16 valve (Triton)	1997-05	26
			330 (5.4L) SOHC CNG 16 valve (Triton)	1997-05	26
			330 (5.4L) SOHC Supercharged 16 valve (Triton)	1999-05	26
330 (5.4L) SOHC Bi-Fuel 16 valve (Triton)	1998-05	26			
8B1784 STD 010 020	CHRYSLER	V8	287 (4.7L) SOHC 16 valve	1999-05	25
10B1442 STD 010 020 030	FORD	V10	415 (6.8L) SOHC 20 valve (Triton)	1997-06	32

MORESA

NÚMERO BANCADA

No. de Parte	Armadora	CIL.	MOTOR / APLICACIÓN	AÑO	LINEA
Part Number	Manufacturer	CYL.	ENGINE / APPLICATION	YEAR	LINE
3C1055 STD 010 020 030	NISSAN	L4	E1 (1.2L)	1961-66	2
			J (1.3L)	1965-69	2
			J13 (1.3L)	1969-75	2
			J15 (1.4L)	1970-79	2
			J16 (1.6L)	1972-85	2
3C1329 STD 010 020 030 040 050	NISSAN	L4	E1 (1.2L)	1961-66	2
			J (1.3L)	1965-69	2
			J13 (1.3L)	1969-75	2
			J15 (1.4L)	1970-79	2
			J16 (1.6L)	1972-85	2
			J18 (1.8L)	1981-93	7
4C517 STD 010 020 030 040	CHRYSLER	L6	170 (2.8L) OHV	1960-71	13
			198 (3.2L) OHV	1969-76	13
			225 (3.7L) H225, HA225, HB225, HC225	1960-87	19
4C518 STD 010 020	FORD	L6	144 (2.4L) OHV	1960-64	10
			170 (2.8L) OHV	1961-72	10
			200 (3.3L) OHV	1963-64	10
4C822 STD 010 020 030	VW	4	1200 (1.2L) 112,113,126	1966-04	1
			1300 (1.3L)	1966-04	1
			1500 (1.5L) 311,341	1966-04	1
			1600 (1.6L) 122,126, 211, 311	1966-04	1

NÚMERO BANCADA

MORESA!

No. de Parte	Armadora	CIL.	MOTOR / APLICACIÓN	AÑO	LINEA
Part Number	Manufacturer	CYL.	ENGINE / APPLICATION	YEAR	LINE
4C943 STD 010 020 030 040	VW	4	1200 (1.2L) 112,113,126	1966-04	1
			1300 (1.3L)	1966-04	1
			1500 (1.5L) 311,341	1966-04	1
			1600 (1.6L) 122,126, 211, 311	1966-04	1
4C960 STD 010 020 030	CHRYSLER	V6	225 (3.7L) Buick engine OHV	1965-71	18
	GM	V6	181 (3.0L) Buick OHV	1982-88	14
			231 (3.8L) Buick Turbo OHV	1978-89	14
			196 (3.2L) Buick OHV	1964-77	16
			252 (4.1L) Buick OHV	1980-84	16
			204 (3.3L) Buick OHV	1988-93	18
			225 (3.7L) Buick OHV	1964-77	20
			231 (3.8L) Buick OHV, Vin "C", "L", Series I	1988-95	21
			231 (3.8L) Buick OHV, Vin "K", Series II	1995-04	21
			231 (3.8L) Buick Supercharged OHV, Vin "1"	1991-04	21
			231 (3.8L) Buick OHV, Exc. 3800 Series I and II	1975-88	21
			231 (3.8L) Buick OHV, Vin "C", "L", Series I	1988-95	21
			231 (3.8L) Buick OHV Type K 3800 Series II	1995-05	21
			231 (3.8L) Buick Supercharged OHV, Vin "1"	1991-05	21
231 (3.8L) Type 1 Supercharged 3800 Series II	1996-99	21			
4C1053 STD 010 020 030	VW	4	1200 (1.2L) 112,113,126	1966-04	1
			1300 (1.3L)	1966-04	1
			1500 (1.5L) 311, 341	1966-04	1
			1600 (1.6L) 122,126, 211, 311	1966-04	1
4C1416 STD 010 020 030	VW	4	1200 (1.2L) 112,113,126	1966-04	1
			1300 (1.3L)	1966-04	1
			1500 (1.5L) 311, 341	1966-04	1
			1600 (1.6L) 122,126, 211, 311	1966-04	1

No. de Parte	Armadora	CIL.	MOTOR / APLICACIÓN	AÑO	LINEA
Part Number	Manufacturer	CYL.	ENGINE / APPLICATION	YEAR	LINE
4C1417 STD 010 020 030	VW	4	1200 (1.2L) 112,113,126	1966-04	1
			1300 (1.3L)	1966-04	1
			1500 (1.5L) 311,341	1966-04	1
			1600 (1.6L) 122,126,211,311	1966-04	1
4C1419 STD 010 020 030 040	CHRYSLER	L6	170 (2.8L) OHV	1960-71	13
			198 (3.2L) OHV	1969-76	13
			225 (3.7L) OHV	1960-87	20
4C1454 STD 010 020 030 040	GM	V6	200 (3.3L) Chevrolet OHV	1978-79	17
			229 (3.8L) Chevrolet OHV (K)	1980-84	17
			262 (4.3L) Chevrolet exc. High Output, OHV	1985-06	25
			262 (4.3L) Chevrolet High Output OHV Vin "B" LU4	1990-91	25
			262 (4.3L) Chevrolet Turbo OHV Vin "Z" LB4	1991-93	25
4C1494 STD 010 020 030 040	CHRYSLER	V6	173 (2.8L) Chevrolet OHV, First Design	1980-85	14
	GM	V6	173 (2.8L) Chevrolet OHV, First Design	1980-85	12
			173 (2.8L) Chevrolet OHV, Second Design	1985-93	12
4C1561 STD 010 020 030 040	FORD	V6	232 (3.8L) OHV	1982-04	17
			232 (3.8L) Supercharged OHV	1989-95	17
			238 (3.9L) OHV	2004	17

NÚMERO BANCADA

MORESA!

No. de Parte	Armadora	CIL.	MOTOR / APLICACIÓN	AÑO	LINEA
Part Number	Manufacturer	CYL.	ENGINE / APPLICATION	YEAR	LINE
4C1701 STD 010 020 030	CHRYSLER	V6	239 (3.9L) OHV Dodge Truck V6 Engine	1987-03	23
4C1702 STD 010 020 030	FORD	V6	183 (3.0L) OHV exc. SHO eng.	1986-06	15
4C1720 STD 010 020 030	CHRYSLER	V6	181 (3.0L) 6G72 Mits. SOHC 12 valve	1987-00	15
			181 (3.0L) 6G72 Mits. DOHC 24 valve	1991-96	15
			181 (3.0L) 6G72 Mits. Turbo DOHC 24 valve	1991-96	15
			181 (3.0L) 6G72 DOHC (Nat. Asp.)	1991-99	15
	MITSUBISHI	V6	6G72 (3.0L)	1986-92	6
			6G72 (3.0L) SOHC 12 valve	1988-99	6
			6G72 (3.0L) SOHC 24 valve	1994-05	6
			6G72 (3.0L) DOHC 24 valve	1991-99	6
6G72T (3.0L) Turbo DOHC 24 valve	1991-99	6			
4C1812 STD 010 020 030	FORD	V6	232 (3.8L) OHV	1982-04	17
			232 (3.8L) Supercharged OHV	1989-95	17
			238 (3.9L) OHV	2004	17
			256 (4.2L) OHV	1997-06	21
4C1822 STD 010 020 030	GM	V6	204 (3.3L) Buick OHV	1988-93	18
			231 (3.8L) Buick OHV, Vin "C", "L", Series I	1988-95	21
			231 (3.8L) Buick OHV, Vin "K", Series II	1995-04	21
			231 (3.8L) Buick Supercharged OHV, Vin "1"	1991-04	21
			231 (3.8L) Buick OHV, Exc. 3800 Series I and II	1975-88	21
			231 (3.8L) Buick OHV, Vin "C", "L", Series I	1988-95	21
			231 (3.8L) Buick OHV Type K 3800 Series II	1995-05	21
			231 (3.8L) Buick Supercharged OHV, Vin "1"	1991-05	21
231 (3.8L) Type 1 Supercharged 3800 Series II	1996-99	21			

No. de Parte	Armadora	CIL.	MOTOR / APLICACIÓN	AÑO	LINEA
Part Number	Manufacturer	CYL.	ENGINE / APPLICATION	YEAR	LINE
4C1946 STD 010 020 030 040	CHRYSLER	V6	201 (3.3L) OHV	1990-06	16
			231 (3.8L) OHV	1991-06	16
4C1951 STD 010 020 030	FORD	V6	181 (3.0L) Nissan SOHC 12 valve	1993-98	14
			199.8 (3.3L) Nissan SOHC 12 valve	1999-02	14
	NISSAN	V6	VG30 (3.0L)	1983-	13
			VG30D (3.0L)	1987-	13
			VG30 (3.0L) SOHC 12 valve	1984-89	13
			VG30E, VG30i (3.0L) SOHC 12 valve	1984-98	13
			VG30T (3.0L) Turbo SOHC 12 valve	1984-98	13
			VG30DE (3.0L) DOHC 24 valve	1984-98	13
			VG30DETT (3.0L) Twin Turbo DOHC 24 valve	1990-96	13
VG33E (3.3L) SOHC 12 valve	1996-04	13			
4C1983 STD 010 020 030 040	FORD	V6	159 (2.6L) OHV	1972-73	12
			171 (2.8L) OHV	1974-79	13
			171 (2.8L) OHV	1983-86	13
			171 (2.8L) OHV	1983-86	13
4C2006 STD 010 020 030 040	FORD	V6	244 (4.0L) OHV	1990-00	19
			244 (4.0L) SOHC 12 valve	1997-01	19
			244 (4.0L) Flex Fuel SOHC 12 valve	2002-03	19

NÚMERO BANCADA

MORESA!

No. de Parte	Armadora	CIL.	MOTOR / APLICACIÓN	AÑO	LINEA
Part Number	Manufacturer	CYL.	ENGINE / APPLICATION	YEAR	LINE
4C2010 STD 010 020 030	CHRYSLER	V6	215 (3.5L) OHV Chrysler V6 Engine	1993-97	17
4C2022 STD 010 020 030	GM	V6	231 (3.8L) Buick OHV, Vin "C", "L", Series I	1988-95	21
			231 (3.8L) Buick OHV, Vin "K", Series II	1995-04	21
			231 (3.8L) Buick Supercharged OHV, Vin "1"	1991-04	21
			231 (3.8L) Buick OHV, Exc. 3800 Series I and II	1975-88	21
			231 (3.8L) Buick OHV, Vin "C", "L", Series I	1988-95	21
			231 (3.8L) Buick OHV Type K 3800 Series II	1995-05	21
			231 (3.8L) Buick Supercharged OHV, Vin "1"	1991-05	21
			231 (3.8L) Type 1 Supercharged 3800 Series II	1996-99	21
4C2037 STD 010 020 030 040	CHRYSLER	V6	173 (2.8L) Chevrolet OHV, First Design	1980-85	14
	GM	V6	173 (2.8L) Chevrolet OHV, First Design	1980-85	12
			173 (2.8L) Chevrolet OHV, Second Design	1985-93	12
			173 (2.8L) Chevrolet LPG	1987-89	13
			173 (2.8L) Chevrolet Meth	1987-89	13
			191 (3.1L) Types D,M,T,W,V6	1988-05	13
			191 (3.1L) Chevrolet Turbo OHV	1989-90	13
			207 (3.4L) OHV Type S	1993-03	13
			207 (3.4L) DOHC 24 valve Type X	1991-97	13
			207 (3.4L) OHV Type S	1993-03	19
207 (3.4L) DOHC 24 valve Type X	1991-97	19			
4C2209 STD 25MM 50MM	CHRYSLER	V6	167 (2.7L) DOHC 24 valve	1998-05	12
4C2244 STD 25MM 50MM	CHRYSLER	V6	226 (3.7L) EKG SOHC 12 valve	2002-06	21

No. de Parte	Armadora	CIL.	MOTOR / APLICACIÓN	AÑO	LINEA
Part Number	Manufacturer	CYL.	ENGINE / APPLICATION	YEAR	LINE
4C3000 STD 010 020 030	FORD	V6	155 (2.5L) Duratec DOHC 24 valve	1995-02	11
			181 (3.0L) Duratec DOHC 24 valve	1996-06	11
5C445 STD 010 020 030	FORD	V8	330 (5.4L) OHV	1964-78	27
			332 (5.4L) OHV	1958-59	27
			352 (5.7L) OHV	1964-67	27
			352 (5.8L) OHV	1958-63	27
			361 (5.9L) OHV	1964-78	27
			361 (5.9L) OHV	1958-59	27
			390 (6.4L) OHV	1961-63	27
			390 (6.4L) OHV	1964-76	27
5C540 STD 010 020 030 040	CHRYSLER	V8	273 (4.5L) OHV	1964-69	24
			277 (4.6L) OHV	1956-57	24
			301 (4.9L) OHV	1957	24
			303 (5.0L) OHV	1956	24
			313 (5.1L) OHV	1957-58	24
			318 (5.2L) OHV	1957-73	24
			318 (5.2L) OHV	1974-03	24
			318 (5.2L) OHV	1993-98	24
			326 (5.3L) OHV	1959	24
			340 (5.7L) OHV	1968-73	26
5C590 STD 010 020 030 040	FORD	V8	221 (3.7L) OHV	1962-63	23
			255 (4.2L) OHV	1980-82	23
			260 (4.3L) OHV	1962-65	23
			289 (4.7L) OHV exc. Vin "K" and w/ A4 trans.	1965-68	23
			289 (4.7L) OHV w/ A4 trans	1963-64	23
			289 (4.7L) OHV w/ Vin "K"	1963-68	23
			302 (4.9L) OHV w/ Boss and Eliminator engs.	1969-71	23
			302 (5.0L) OHV exc. Boss and Eliminator engs.	1968-01	23
			302 (5.0L) High Output OHV exc. Boss and Eliminator engs.	1982-95	23

NÚMERO BANCADA

MORESA!

No. de Parte	Armadora	CIL.	MOTOR / APLICACIÓN	AÑO	LINEA
Part Number	Manufacturer	CYL.	ENGINE / APPLICATION	YEAR	LINE
5C616 STD 010 020 030 040	CHRYSLER	L4	151 (2.5L) Pontiac Engine OHV	1980-83	10
5C685 STD 010 020 030 040	FORD	V8	330 (5.4L) OHV	1964-78	27
			332 (5.4L) OHV	1958-59	27
			352 (5.7L) OHV	1964-67	27
			352 (5.8L) OHV	1958-63	27
			361 (5.9L) OHV	1964-78	27
			361 (5.9L) OHV	1958-59	27
			390 (6.4L) OHV	1961-63	27
			390 (6.4L) OHV	1964-76	27
5C829 STD 010 020 030 040	GM	V8	366 (6.0L) Chevrolet OHV	1966-00	37
			396 (6.5L) Chevrolet OHV	1965-70	37
			402 (6.6L) Chevrolet OHV	1970-72	37
			427 (7.0L) Chevrolet OHV	1966-00	37
			454 (7.4L) Chevrolet OHV	1970-00	37
			502 (8.2L) Chevrolet Gen IV, V, VI OHV	1990-01	37
5C876 STD 010 020 030	CHRYSLER	V8	350 (5.7L) OHV	1958	28
			361 (5.9L) OHV	1958-77	28
			361.1 (5.9L) OHV	1966-67	28
			383 (6.3L) OHV	1961-71	28
			400 (6.6L) OHV	1972-80	28

MORESA

NÚMERO BANCADA

No. de Parte	Armadora	CIL.	MOTOR / APLICACIÓN	AÑO	LINEA
Part Number	Manufacturer	CYL.	ENGINE / APPLICATION	YEAR	LINE
5C909 STD 010 020 030 040	GM	V8	262 (4.3L) Chevrolet OHV Vin "G"	1975-76	28
			265 (4.3L) Chevrolet L99 OHV Vin "W"	1994-96	28
			267 (4.4L) Chevrolet OHV Vin "J"	1979-82	28
			305 (5.0L) Chevrolet OHV	1976-99	28
			307 (5.0L) Chevrolet OHV	1968-73	28
			327 (5.4L) Chevrolet OHV Vin "L"	1968-69	28
			302 (4.9L) Chevrolet OHV	1967-69	33
			327 (5.4L) Chevrolet OHV	1962-69	33
350 (5.7L) Chevrolet OHV, Inc. LT1, Exc. DOHC	1967-02	33			
5C963 STD 010 020 030	CHRYSLER	V8	340 (5.7L) OHV	1968-73	26
5C981 STD 010	FORD	V8	335 (5.5L) MÉXICO	1969-86	28
			351W (5.8L)	1969-99	28
			351M (5.8L) OHV	1975-82	29
			400 (6.6L) OHV	1971-82	29
5C1038 STD 010 020 030 040	GM	V8	400 (6.6L) Chevrolet OHV	1970-80	38
5C1039 STD 010 020 030 040	FORD	V8	370 (6.1L) OHV	1979-91	31
			429 (7.0L) OHV Truck	1979-98	31
			429 (7.0L) OHV Pass.	1968-73	31
			460 (7.5L) OHV	1968-98	31

NÚMERO BANCADA

MORESA!

No. de Parte	Armadora	CIL.	MOTOR / APLICACIÓN	AÑO	LINEA
Part Number	Manufacturer	CYL.	ENGINE / APPLICATION	YEAR	LINE
5C1051 STD 010 020 030 040	CHRYSLER	V8	360 (5.9L) OHV	1971-03	29
			360 (5.9L) OHV	1974-01	29
			360 (5.9L) OHV	1971-73	29
			360 (5.9L) Chrysler OHV	1974-2001	29
			360 (5.9L) OHV	1971-78	29
			360 (5.9L) OHV	1979-99	29
5C1054 STD 010 020 030 040	NISSAN	L4	L16 (1.6L)	1967-89	4
			L18 (1.8L)	1970-81	4
5C1102 STD 010 020 030	TOYOTA	L4	8RC (1.9L) SOHC	1969-71	3
			18RC (2.0L) SOHC	1972-74	3
5C1107 STD 010 020 030	NISSAN	L4	A12 (1.2L)	1970-82	1
			A12A (1.2L)	1978-81	1
			A13 (1.3L)	1976-81	1
			A13S (1.3L)	1976-81	1
			A14 (1.4L)	1974-84	1
			A15 (1.5L)	1980-91	1
5C1117 STD 010 020 030	FORD	L4	122 (2.0L) SOHC 8 valve	1983-88	7
			140 (2.3L) SOHC 8 valve	1974-97	7
			140 (2.3L) Turbo SOHC 8 valve	1979-90	7
			153 (2.5L) SOHC 8 valve	1998-01	7

MORESA

NÚMERO BANCADA

No. de Parte	Armadora	CIL.	MOTOR / APLICACIÓN	AÑO	LINEA
Part Number	Manufacturer	CYL.	ENGINE / APPLICATION	YEAR	LINE
5C1140 STD 010 020 030	RENAULT	L4	697.01 (1.5L)	1966-70	2
			807 03/04/05/06 (1.6L)	1969-85	2
			807 10/11 (1.6L)		2
			807 12/13/20 (1.6L)		2
			821 (9CV) (1.6L)		2
			807 A 7 27 (1.6L)		2
			843/841 (1.6L)	1973-77	2
			841/841 (1.6L) (A2M)		2
			841-99 (1.6L) A1M		2
5C1157 STD 010 020 030	AUDI	L4	1500 (1.5L)	1972-	1
			1588 cc (1.6L)	1972-	1
			1600 (1.6L) ABB,ABM,ADA,ADP- AEH,DT,JU,PP,RN	1985 -	1
			1800 (1.8L) ADR/AEB/AGN/AGU- DR/DS/DZ -	1982-	2
			JN/JV/JW/ - NE/NP/PH/PM/PV - RS/RU/SH/4B		
			2000 (2.0L) AAD,AAE,ABK,ABT- ADW,3A,6A	1986-	2
	VW	L4	EH, FX (1.5L)	1978-80	2
			CK DIESEL (1.5L)	1977-80	2
			FC, FG, XR, XS, XV, XW, XY, XZ (1.5L)	1974-75	2
			EE, EJ, FN, YG, YH, YK (1.6L)	1976-80	2
			CR, CS, JK DIESEL (1.6L)	1981-84	3
			ME DIESEL (1.6L)	1985	3
			CY, MD, MF (1.6L) Turbocharged	1982-86	3
			(1.6L) SOHC 8 valve Turbocharged	1992	3
			SOHC (1.6L)	1981-85	4
			SOHC (1.7L)	1979-	4
			(1.8L) SOHC JH, JN	1983-89	4
			(1.8L) DOHC PL	1986-89	4
			2H, ABG, HT, PF, PG, RD, RV, UM (1.8L) Supercharged	1990-92	4
			1800 (1.8L) A, G, J series - K, P, R series	1982-	5
			2000 (2.0L) A,KR,2E,9A series	1990-	5
			9A DOHC (2.0L)	1990-94	6
			ABA (2.0L) SOHC	1993-98	6

NÚMERO BANCADA

MORESA!

No. de Parte	Armadora	CIL.	MOTOR / APLICACIÓN	AÑO	LINEA
Part Number	Manufacturer	CYL.	ENGINE / APPLICATION	YEAR	LINE
5C1183 STD 010 020 030	RENAULT	L4	688/689/C1C (1.0L)	1963-66	1
			688/12/10, 688688.02, 688.01, 688.02/06/10/11, 688.09 (1.1L)	1965-66	1
			CIE 715 (1.1L)	1964-69	1
			CIE 715 (1.1L)	1964-69	1
			CIE,750/G750 (1.1L)	1964-69	1
			810/25/26/29/03 (1.3L)	1969-79	1
			C1J,C2J,C3J,847 (1.4L)		1
			847 700/701,C1J (1.4L)		1
			CIJ 760/764/782 (1.4L) Turbocharged		1
			CIJ,C2J,C3J (1.3L)		1
840-25 (1.3L)		1			
5C1266 STD 010 020 030 040	CHRYSLER	V8	360 (5.9L) OHV	1971-03	29
			360 (5.9L) OHV	1974-01	29
			360 (5.9L) OHV	1971-73	29
			360 (5.9L) Chrysler OHV	1974-01	29
			360 (5.9L) OHV	1971-78	29
			360 (5.9L) OHV	1979-99	29
5C1298 STD 010 020 030	GM	L4	111 (1.8L) Isuzu SOHC 8 valve	1972-82	5
			119 (1.9L) Isuzu SOHC 8 valve LR1	1982-85	5
	ISUZU	L4	G180 (1.8L) SOHC 8 valve	1969-87	1
			4FB1, 4FB1-T (1.8L)	1979-86	1
			G200 (2.0L)	1988-89	3
			G200 (2.0L) SOHC 8 valve	1988-89	3
5C1344 STD 010 020 030 040	CHRYSLER	V8	273 (4.5L) OHV	1964-69	24
			277 (4.6L) OHV	1956-57	24
			301 (4.9L) OHV	1957	24
			303 (5.0L) OHV	1956	24
			313 (5.1L) OHV	1957-58	24
			318 (5.2L) OHV	1957-73	24
			318 (5.2L) OHV	1974-03	24
			318 (5.2L) OHV	1993-98	24
			326 (5.3L) OHV	1959	24
			340 (5.7L) OHV	1968-73	26

No. de Parte	Armadora	CIL.	MOTOR / APLICACIÓN	AÑO	LINEA
Part Number	Manufacturer	CYL.	ENGINE / APPLICATION	YEAR	LINE
5C1381 STD 010 020 030	RENAULT	L4	688/689/C1C (1.0L)	1963-66	1
			688/12/10, 688688.02, 688.01, 688.02/06/10/11, 688.09 (1.1L)	1965-66	1
			CIE 715 (1.1L)	1964-69	1
			CIE 715 (1.1L)	1964-69	1
			CIE,750/G750 (1.1L)	1964-69	1
			810/25/26/29/03 (1.3L)	1969-79	1
			C1J,C2J,C3J,847 (1.4L)		1
			847 700/701,C1J (1.4L)		1
			CIJ 760/764/782 (1.4L) Turbocharged		1
			CIJ,C2J,C3J (1.3L)		1
840-25 (1.3L)		1			
5C1424 STD 010 020 030	GM	L4	85 (1.4L) Chevrolet SOHC 8 valve	1976-77	2
			98 (1.6L) Chevrolet SOHC 8 valve	1976-87	2
5C1427 STD 010 020 030	FORD	L4	110 (1.8L) Mazda VB SOHC 8 valve	1972-78	3
			121 (2.0L) Mazda MB SOHC 8 valve	1979-82	3
	MAZDA	L4	UB (1.5L)	1970-73	2
			NA (1.6L) SOHC 8 valve	1970-77	2
			VC (1.8L)	1973-86	2
			VB (1.8L) SOHC 8 valve	1968-78	3
MA (2.0L) SOHC 8 valve	1977-89	3			
5C1428 STD 010 020 030	TOYOTA	L4	20R (2.2L) SOHC 8 valve	1974-82	5
			22R (2.4L) SOHC 8 valve	1980-90	5
			22RE (2.4L) SOHC 8 valve	1989-95	5
			22REC (2.4L) SOHC 8 valve	1983-88	5
			22RTEC (2.4L) Turbo SOHC 8 valve	1985-88	5

NÚMERO BANCADA

MORESA!

No. de Parte	Armadora	CIL.	MOTOR / APLICACIÓN	AÑO	LINEA
Part Number	Manufacturer	CYL.	ENGINE / APPLICATION	YEAR	LINE
5C1431 STD 010 020 030	HONDA	L4	EB1 (1.2L) SOHC 8 valve	1973	1
			EB2,EB3 (1.2L) SOHC 8 valve	1974-79	1
			EE (1.2L) SOHC 8 valve	1975-79	1
			EJ1 (1.3L) SOHC 8 valve	1980-83	1
			EN (1.3L) SOHC 8 valve	1979-83	1
			EV2 (1.3L) SOHC 8 valve	1983-87	2
			EM1 (1.5L) SOHC 8 valve	1979-83	2
			EW1,EW3,EW4 (1.5L) SOHC 12 valve	1984-86	2
			ED1,ED2,ED3,ED4 (1.5L) SOHC 8 valve	1974-78	2
			EF1 (1.6L) SOHC 8 valve	1976-86	2
			EK,EK1 (1.8L) SOHC 8 valve	1978-83	2
			ED1,ED2,ED3,ED4 (1.5L) SOHC 8 valve	1974-78	3
			EM1 (1.5L) SOHC 8 valve	1979-83	3
			EF1 (1.6L) SOHC 8 valve	1976-86	3
			EP (1.6L) SOHC 8 valve	1980-86	3
EK,EK1 (1.8L) SOHC 8 valve	1978-83	3			
5C1432 STD 010 020 030 040	FORD	V8	335 (5.5L) MÉXICO	1969-86	28
			351W (5.8L)	1969-99	28
			351M (5.8L) OHV	1975-82	29
			400 (6.6L) OHV	1971-82	29
5C1456 STD 010 020 030 040	TOYOTA	L4	2TC (1.6L) OHV	1971-79	2
			12T (1.6L)	1976-84	2
			3TC (1.8L) OHV, 3T-G	1980-82	2
			13T (1.8L)	1977-82	2
			4T-G (1.8L)	1982-84	2
5C1533 STD 010 020 030	CHRYSLER	L4	135 (2.2L) SOHC 8 valve	1981-94	6
			135 (2.2L) DOHC 8 valve	1988-91	6
			135 (2.2L) Turbo SOHC 8 valve	1984-90	6
			135 (2.2L) Turbo DOHC 16 valve	1988-93	6
			153 (2.5L) SOHC 8 valve	1986-95	9
			153 (2.5L) Turbo SOHC 8 valve	1989-92	9

No. de Parte	Armadora	CIL.	MOTOR / APLICACIÓN	AÑO	LINEA
Part Number	Manufacturer	CYL.	ENGINE / APPLICATION	YEAR	LINE
5C1545 STD 010 020 030	GM	L4	1.4 L	1994-03	1
			1.6 L	1996-08	1
			C 16 NZ/E 16 SE /X 16 SZR (1.6L)		1
			X 16 XE/XEL (1.6L)		1
5C1559 STD 010 020 030 040	CHRYSLER	L4	98 4G61 (1.6L) Mits. DOHC 16 valve	1990	3
			98 4G61T (1.6L) Mits. Turbo DOHC 16 valve	1989	3
			98 G32BT (1.6L) Mits. Turbo SOHC 8 valve	1971-84	3
			98 G32B (1.6L) Mits. SOHC 8 valve, Type K & Z	1971-84	3
			107 4G37 (1.8L) Mits. SOHC 8 valve	1989-92	3
			122 4G63 (2.0L) Mits. SOHC 8 valve	1983-92	3
			122 4G63 (2.0L) Mits. DOHC 16 valve	1989-94	3
			122 4G63T (2.0L) Mits. Turbo DOHC 16 valve	1989-94	3
			144 4G64 (2.4L) Mits. SOHC 8 valve	1989-94	3
			144 4G64 (2.4L) Mits. SOHC 8 valve	1993-94	3
	MITSUBISHI	L4	4G61 (1.6L) DOHC 16 valve	1991-92	3
			4G61T (1.6L) Turbo DOHC 16 valve	1989-90	3
			G32B (1.6L) Turbo SOHC 12 valve	1985-88	3
			G32B, (1.6L) 4G32		3
			4G37 (1.8L) SOHC 8 valve	1989-94	3
			4G63 (2.0L) SOHC 8 valve	1989-92	4
			4G63 (2.0L) DOHC 16 valve	1989-94	4
			4G63T (2.0L) Turbo DOHC 16 valve	1989-94	4
			G64B, 4G64 (2.4L)	1985-00	4
			G64B (2.4L) SOHC 12 valve	1985-88	4
			4G64 (2.4L) SOHC 8 valve	1989-96	4
			4G64 (2.4L) SOHC 16 valve	1993-05	4
4G64 (2.4L) DOHC 16 valve	1994	4			
5C1560 STD 010 020 030	MAZDA	L4	TC (1.3L) SOHC	1978	1
			UC (1.4L) SOHC	1979-80	1
			E5 (1.5L) SOHC	1981-85	1

NÚMERO BANCADA

MORESA

No. de Parte	Armadora	CIL.	MOTOR / APLICACIÓN	AÑO	LINEA
Part Number	Manufacturer	CYL.	ENGINE / APPLICATION	YEAR	LINE
5C1568 STD 010 020 030 040	CHRYSLER	L4	150 (2.5L) Jeep OHV	1983-90	8
	VAM	L4	150 (2.5L)	1983-88	1
5C1570 STD 010 020 030 040	NISSAN	L4	L20B (2.0L) SOHC 8 valve	1974-80	9
			LD20 (2.0L)	1978-91	9
			Z20, Z20E, Z20S (2.0L) SOHC 8 valve	1975-86	9
			Z22, Z22E (2.2L) SOHC 8 valve	1982-88	9
			Z24, Z24i (2.4L) SOHC 8 valve	1983-89	9
5C1590 STD 010 020 030	TOYOTA	L4	20R (2.2L) SOHC 8 valve	1974-82	5
			22R (2.4L) SOHC 8 valve	1980-90	5
			22RE (2.4L) SOHC 8 valve	1989-95	5
			22REC (2.4L) SOHC 8 valve	1983-88	5
			22RTEC (2.4L) Turbo SOHC 8 valve	1985-88	5
5C1595 STD 010 020 030	NISSAN	L4	E15, E15S (1.5L) SOHC 8 valve	1981-91	3
			E15T (1.5L) Turbo SOHC 8 valve	1983-84	3
			E16 (1.6L) SOHC 8 valve	1983-86	3
			E16I, E16S (1.6L) SOHC 8 valve	1986-88	3
5C1629 STD 010 020 030	FORD	L4	140 (2.3L) HSC OHV	1984-85	9
			140 (2.3L) HSC OHV	1984-94	9
			153 (2.5L) HSC OHV	1986-91	9

No. de Parte	Armadora	CIL.	MOTOR / APLICACIÓN	AÑO	LINEA
Part Number	Manufacturer	CYL.	ENGINE / APPLICATION	YEAR	LINE
5C1638 STD 010 020 030 040	GM	L4	97 (1.6L) Toyota SOHC 8 valve	1985-89	3
			97 (1.6L) Toyota SOHC 16 valve	1988-89	3
	TOYOTA	L4	3AC (1.5L) SOHC 8 valve	1979-90	1
			1AC (1.5L) SOHC 8 valve	1978-80	1
			5A (1.5L)	1987-	1
			4ALC (1.6L) SOHC 8 valve	1983-88	1
			4AC (1.6L) SOHC 8 valve	1983-87	1
			4AF (1.6L) DOHC 16 valve	1988-89	1
			4AFE (1.6L) DOHC 16 valve	1989-97	1
			4AGEC (1.6L) DOHC 16 valve	1985-87	1
			4AGELC (1.6L) DOHC 16 valve	1985-89	1
			4AGZE (1.6L) Supercharged DOHC 16 valve	1987-89	1
	4AGE (1.6L) DOHC 16 valve	1988-91	1		
5C1668 STD 010 020 030	CHRYSLER	L4	86 G12B (1.4L) Mits. SOHC 8 valve	1979-84	2
			92 4G15 (1.4L) Mits. SOHC 8 valve, carb. 4G15	1985-90	2
			92 4G15 (1.4L) Mits. SOHC 8 valve, F.I.	1987-90	2
			92 4G15 (1.4L) Mits. SOHC 12 valve	1991-94	2
	MITSUBISHI	L4	G11B, 4G11 (1.3L)	1977-85	1
			G13B, 4G13 (1.3L)	1983-	1
			G12B, 4G12 (1.4L)	1976-88	1
			G15B, 4G15, G4AJ (1.5L) SOHC 8 valve	1983-90	1
			4G15 (1.5L) SOHC 12 valve	1991-02	1
			G4AJ (1.5L) 8 valve	1987-89	1
			G15B, 4G15, G4AJ (1.5L) SOHC 8 valve	1989-90	2
4G15 (1.5L) SOHC 12 valve	1991-02	2			
G4DJ (1.5L) 8 valve	1990-94	2			
5C1703 STD 010 020	GM	L4	138 (2.3L) Oldsmobile SOHC 8 valve	1992-94	9
			138 (2.3L) Oldsmobile DOHC 16 valve	1987-96	9

NÚMERO BANCADA

MORESA!

No. de Parte	Armadora	CIL.	MOTOR / APLICACIÓN	AÑO	LINEA
Part Number	Manufacturer	CYL.	ENGINE / APPLICATION	YEAR	LINE
5C1706 STD 010 020 030	FORD	L4	116 (1.9L) SOHC 8 valve	1985-96	4
			121 (2.0L) SOHC 8 valve	1997-04	4
5C1714 STD 010 020 030 040	TOYOTA	L4	2SELC (2.0L) SOHC 8 valve	1982-86	4
			3SGELC (2.0L) DOHC 16 valve	1987-91	4
			3SFE (2.0L) DOHC 16 valve	1987-00	4
			3YEC (2.0L) OHV	1982-85	4
			3SGTE (2.0L) Turbo DOHC 16 valve	1986-95	4
			5SFE (2.2L) DOHC 16 valve	1985-01	4
5C1733 STD 010 020 030	CHRYSLER	L4	151 (2.5L) Pontiac Engine OHV	1980-83	10
	GM	L4	151 (2.5L) Pontiac OHV	1977-84	11
			151 (2.5L) Pontiac OHV Vin "R", "2"	1985-92	11
			151 (2.5L) Pontiac OHV Vin "A", "E"	1985-93	11
VAM	L4	151 (2.5L) Pontiac Engine	1980-83	2	
5C1743 STD 010 020 030 040	FORD	L4	122 (2.0L) SOHC 8 valve	1983-88	7
			140 (2.3L) SOHC 8 valve	1974-97	7
			140 (2.3L) Turbo SOHC 8 valve	1979-90	7
			153 (2.5L) SOHC 8 valve	1998-01	7
	MAZDA	L4	140 Ford SOHC 8 valve	1994-97	5
			153 Ford SOHC 8 valve	1998-01	5
5C1749 STD 010 020 030 040	GM	L4	121 (2.0L) OHV LL8	1987-89	7
			134 (2.2L) OHV Types G,4	1990-97	7

No. de Parte	Armadora	CIL.	MOTOR / APLICACIÓN	AÑO	LINEA
Part Number	Manufacturer	CYL.	ENGINE / APPLICATION	YEAR	LINE
5C1775 STD 010 020 030	ISUZU	L4	4ZC1 (2.0L) SOHC Turbo	1985-89	2
			4ZD1 (2.2L) SOHC 8 valve	1986-95	2
5C1803 STD 010 020 030	FORD	L4	133 (2.2L) Mazda SOHC 12 valve	1989-92	8
			133 (2.2L) Mazda Turbo SOHC 12 valve	1989-92	8
	MAZDA	L4	FE (2.0L) SOHC 8 valve	1982-87	4
			FE (2.0L) Turbo SOHC 8 valve	1986-87	4
			FEH1, FEH5 (2.0L)	1983-87	4
			F2 (2.2L) SOHC 8 valve	1987-93	4
			F2 (2.2L) SOHC 12 valve	1987-93	4
F2 (2.2L) Turbo SOHC 12 valve	1988-92	4			
5C1945 STD 010 020 030	CHRYSLER	L4	122 (2.0L) G52B Mits. SOHC 8 valve	1974-82	5
			156 (2.6L) G54B Mits. SOHC 8 valve, Type F	1978-87	5
			156 (2.6L) G54B Mits. SOHC 8 valve, Type W	1979-90	5
			156 (2.6L) G54B Mits. Turbo SOHC 8 valve	1984-90	5
	MITSUBISHI	L4	4G54 (2.6L)	1983-89	5
			G54B, 4G54 (2.6L) SOHC 12 valve	1983-89	5
G54B (2.6L) Turbo SOHC 12 valve	1983-89	5			
5C1948 STD 010 020 030 040	CHRYSLER	L4	150 (2.5L) Jeep OHV	1981-02	8
5C1949 STD 010 020 030 040	NISSAN	L4	KA24DE (2.4L) DOHC 16 valve	1999-08	11
			KA24E (2.4L) SOHC 12 valve	1989-98	11

NÚMERO BANCADA

MORESA!

No. de Parte	Armadora	CIL.	MOTOR / APLICACIÓN	AÑO	LINEA
Part Number	Manufacturer	CYL.	ENGINE / APPLICATION	YEAR	LINE
5C1950 STD 010 020 030 040	NISSAN	L4	GA16DE (1.6L) DOHC 16 valve	1991-99	5
			GA16I (1.6L) SOHC 12 valve	1989-90	5
5C2007 STD 010 020 030 040	FORD	V8	281 (4.6L) SOHC 16 valve	1991-05	25
			281 (4.6L) SOHC CNG 16 valve	1995-03	25
			281 (4.6L) SOHC LPG 16 valve	1997-98	25
			281 (4.6L) DOHC 32 valve (Triton)	1993-04	25
			281 (4.6L) DOHC 32 valve Supercharged / Intercooled (Triton)	2003-04	25
5C2015 STD 010 020 030	NISSAN	L4	SR20DE (2.0L) DOHC 16 valve	1991-02	10
5C2028 STD 010 020 030	CHRYSLER	L4	122 (2.0L) SOHC 16 valve	1995-06	4
			122 (2.0L) DOHC 16 valve	1995-99	4
5C2056 STD 010 020	GM	L4	146 (2.4L) DOHC Oldsmobile, LD9, 16 valve	1996-02	10

No. de Parte	Armadora	CIL.	MOTOR / APLICACIÓN	AÑO	LINEA
Part Number	Manufacturer	CYL.	ENGINE / APPLICATION	YEAR	LINE
5C2199 STD 010 020 030	GM	V8	293 (4.8L) Chevrolet Vortec OHV Gen III	1999-06	31
			325 (5.3L) Chevrolet Vortec OHV Gen III	1999-06	31
			346 (5.7L) Chevrolet LS1 Vortec OHV Gen III	1997-04	31
			346 (5.7L) Chevrolet LS6 Vortec OHV Gen III	2001-06	31
			365 (6.0L) Chevrolet Vortec OHV Gen III	1999-06	31
5C2216 STD 010 020	CHRYSLER	V8	287 (4.7L) SOHC 16 valve	1999-05	25
5C3001 STD 010 020 030	FORD	L4	Zetec NGA (2.0L) DOHC 16 Valve	1996-	5
			ZH20 Zetec E		
			122 Zetec (2.0L) DOHC 16 valve	1996-04	5
5C7003 STD 25MM 50MM	FORD	L4	1.3 L, (1.3L) HSC	1998-02	1
			1.4 L, (1.4L) HSC	1998-04	1
			1.6 L (1.6L) HSC, Zetec Rocam ZL	1998-04	1
5C7004 STD 010 020	NISSAN	L4	K4M (1.6L)	1999-08	6
	RENAULT	L4	K4M (1.6L)	1999-08	3
5C7141 STD 010 020 030	FORD	V8	281 (4.6L) SOHC 16 valve	1991-05	25
			281 (4.6L) SOHC CNG 16 valve	1995-03	25
			281 (4.6L) SOHC LPG 16 valve	1997-98	25
			281 (4.6L) DOHC 32 valve (Triton)	1993-04	25
			281 (4.6L) DOHC 32 valve Supercharged / Intercooled (Triton)	2003-04	25

NÚMERO BANCADA

MORESA!

No. de Parte	Armadora	CIL.	MOTOR / APLICACIÓN	AÑO	LINEA
Part Number	Manufacturer	CYL.	ENGINE / APPLICATION	YEAR	LINE
5C7296 STD 010 020 030	FORD	V8	281 (4.6L) SOHC 16 valve	1991-05	25
			281 (4.6L) SOHC CNG 16 valve	1995-03	25
			281 (4.6L) SOHC LPG 16 valve	1997-98	25
			281 (4.6L) DOHC 32 valve (Triton)	1993-04	25
			281 (4.6L) DOHC 32 valve Supercharged / Intercooled (Triton)	2003-04	25
			330 (5.4L) SOHC 16 valve (Triton)	1997-05	26
			330 (5.4L) SOHC CNG 16 valve (Triton)	1997-05	26
			330 (5.4L) SOHC Supercharged 16 valve (Triton)	1999-05	26
330 (5.4L) SOHC Bi-Fuel 16 valve (Triton)	1998-05	26			
5C7313 STD 010 020 030 040	CHRYSLER	L4	148 (2.4L) DOHC, 16 Valve	1995-04	7
			148 (2.4L) Turbo DOHC 16 valve	2003-04	7
			151 (2.5L) Pontiac OHV	1977-84	11
			151 (2.5L) Pontiac OHV Vin "R", "2"	1985-92	11
			151 (2.5L) Pontiac OHV Vin "A", "E"	1985-93	11
5C7000 STD 25MM	CHRYSLER	L4	G4HC (1.0L)	2000-05	1
			1086cc (1.1L) SOHC 12V	2000-05	1
	HYUNDAI	L4	G4HC (1.0L)	2000-04	1
			1086cc (1.1L) SOHC 12V	2004-08	1
6C1434 STD 010 020	VW	L5	2500 (2.5L) AAF,ACU,AET,AEU	2001-05	7
6C7297 STD 010 020 030	FORD	V10	415 (6.8L) SOHC 20 valve (Triton)	1997-06	32

No. de Parte	Armadora	CIL.	MOTOR / APLICACIÓN	AÑO	LINEA
Part Number	Manufacturer	CYL.	ENGINE / APPLICATION	YEAR	LINE
7C617 STD 010 020 030 040	GM	L6	194 (3.2L) Chevrolet OHV	1962-67	15
			215 (3.5L) Pontiac OHV	1964-65	15
			230 (3.8L) Chevrolet OHV	1962-70	15
			230 (3.8L) Pontiac SOHC 12 valve	1966-67	15
			250 (4.1L) Pontiac SOHC 12 valve	1968-69	23
			250 (4.1L) Chevrolet OHV	1966-84	23
			250 (4.1L) Chevrolet OHV	1994-98	23
			292 (4.8L) Chevrolet OHV Vin "T"	1963-90	26
7C704 020 030	CHRYSLER	L6	232 (3.8L) AMC OHV	1965-78	22
			242 (4.0L) Jeep OHV	1987-02	22
			258 (4.2L) AMC OHV	1971-90	22
			258 (4.2L) AMC OHV	1987-90	22
			258 (4.2L) AMC OHV	1991-02	22
	VAM	L6	199 (3.3L)	1965-70	3
			232 (3.8L)	1964-79	3
258 (4.2L)			1971-88	3	
7C771 STD 010 020	FORD	L6	200 (3.3L) OHV	1965-83	16
7C979 STD 010 020 030 040	FORD	L6	240 (3.9L) OHV	1965-74	18
			250 (4.1L) OHV	1969-80	20
			300 (4.9L) OHV	1965-96	22
7C1106 STD 010 020 030	NISSAN	L6	L24 (2.4L)	1971-87	12
			L26 (2.6L)	1971-78	12
			L28 (2.8L)	1975-83	12
			LD28 (2.8L)	1979-86	12

NÚMERO BANCADA

MORESA!

No. de Parte	Armadora	CIL.	MOTOR / APLICACIÓN	AÑO	LINEA
Part Number	Manufacturer	CYL.	ENGINE / APPLICATION	YEAR	LINE
7C1389 STD 010 020 030	FORD	L6	200 (3.3L) OHV	1965-83	16
7C1947 STD 010 020 030	CHRYSLER	L6	232 (3.8L) AMC OHV	1965-78	22
			242 (4.0L) Jeep OHV	1987-02	22
			258 (4.2L) AMC OHV	1971-90	22
			258 (4.2L) AMC OHV	1987-90	22
			258 (4.2L) AMC OHV	1991-02	22
7C2229 STD 010 020	VW	V6	2800 (2.8L) AAA, AES	1996-07	8

MORESA

NÚMERO BUJE DE ÁRBOL

No. de Parte	Armadora	CIL.	MOTOR / APLICACIÓN	AÑO	LINEA
Part Number	Manufacturer	CYL.	ENGINE / APPLICATION	YEAR	LINE
MO1170M STD	GM	L6	235 (3.8L) Chevrolet OHV	1953-62	22
			261 (4.2L) Chevrolet OHV	1954-62	22
			261 (4.3L) Chevrolet OHV	1954-62	22
MO1204M STD 010 020 030	FORD	V8	221 (3.7L) OHV	1962-63	23
			255 (4.2L) OHV	1980-82	23
			260 (4.3L) OHV	1962-65	23
			289 (4.7L) OHV exc. Vin "K" and w/ A4 trans.	1965-68	23
			289 (4.7L) OHV w/ A4 trans	1963-64	23
			289 (4.7L) OHV w/ Vin "K"	1963-68	23
			302 (4.9L) OHV w/ Boss and Eliminator engs.	1969-71	23
			302 (5.0L) OHV exc. Boss and Eliminator engs.	1968-01	23
			302 (5.0L) High Output OHV exc. Boss and Eliminator engs.	1982-95	23
			351W (5.8L)	1969-99	28
MO1235M STD 010 020 030	GM	V8	262 (4.3L) Chevrolet OHV Vin "G"	1975-76	28
			265 (4.3L) Chevrolet L99 OHV Vin "W"	1994-96	28
			267 (4.4L) Chevrolet OHV Vin "J"	1979-82	28
			305 (5.0L) Chevrolet OHV	1976-99	28
			307 (5.0L) Chevrolet OHV	1968-73	28
			327 (5.4L) Chevrolet OHV Vin "L"	1968-69	28
			283 (4.6L) Chevrolet OHV	1957-67	30
			400 (6.6L) Chevrolet OHV	1970-80	38
MO1244M STD 010	VAM	L4	150 (2.5L)	1983-88	1
		L6	199 (3.3L)	1965-70	3
			232 (3.8L)	1964-79	3
			258 (4.2L)	1971-88	3
MO1325M STD 010	NISSAN	L4	E1 (1.2L)	1961-66	2
			J (1.3L)	1965-69	2
			J13 (1.3L)	1969-75	2
			J15 (1.4L)	1970-79	2
			J16 (1.6L)	1972-85	2
			J18 (1.8L)	1981-93	7

NÚMERO BUJE DE ÁRBOL

MORESA!

No. de Parte	Armadora	CIL.	MOTOR / APLICACIÓN	AÑO	LINEA
Part Number	Manufacturer	CYL.	ENGINE / APPLICATION	YEAR	LINE
MO1403M STD 010 020 030	FORD	V8	351M (5.8L) OHV	1975-82	29
			400 (6.6L) OHV	1971-82	29
MO1404M STD 010	GM	V8	366 (6.0L) Chevrolet OHV	1966-00	37
			396 (6.5L) Chevrolet OHV	1965-70	37
			402 (6.6L) Chevrolet OHV	1970-72	37
			427 (7.0L) Chevrolet OHV	1966-00	37
			454 (7.4L) Chevrolet OHV	1970-00	37
			502 (8.2L) Chevrolet Gen IV, V, VI OHV	1990-01	37
			496 (8.1L) Chevrolet Vortec OHV	2001-05	40
MO1414M STD	FORD	V8	370 (6.1L) OHV	1979-91	31
			429 (7.0L) OHV Truck	1979-98	31
			429 (7.0L) OHV Pass.	1968-73	31
			460 (7.5L) OHV	1968-98	31
MO1421M STD	GM	V8	300 (4.9L) Buick OHV	1964-67	32
			340 (5.6L) Buick OHV	1966-67	32
MO1439M STD	FORD	L6	144 (2.4L) OHV	1960-64	10
			170 (2.8L) OHV	1961-72	10
			200 (3.3L) OHV	1963-64	10
			200 (3.3L) OHV	1965-83	16
			250 (4.1L) OHV	1969-80	20
MO1443M STD 010	FORD	L4	122 (2.0L) SOHC 8 valve	1983-88	7
			140 (2.3L) SOHC 8 valve	1974-97	7
			140 (2.3L) Turbo SOHC 8 valve	1979-90	7
			153 (2.5L) SOHC 8 valve	1998-01	7
	MAZDA	L4	140 Ford SOHC 8 valve	1994-97	5
			153 Ford SOHC 8 valve	1998-01	5

MORESA

NÚMERO BUJE DE ÁRBOL

No. de Parte	Armadora	CIL.	MOTOR / APLICACIÓN	AÑO	LINEA
Part Number	Manufacturer	CYL.	ENGINE / APPLICATION	YEAR	LINE
MO1445M STD 010	FORD	V8	330 (5.4L) OHV	1964-78	27
			332 (5.4L) OHV	1958-59	27
			352 (5.7L) OHV	1964-67	27
			352 (5.8L) OHV	1958-63	27
			361 (5.9L) OHV	1964-78	27
			361 (5.9L) OHV	1958-59	27
			390 (6.4L) OHV	1961-63	27
			390 (6.4L) OHV	1964-76	27
			391 (6.4L) OHV	1964-78	27
			359 (5.9L) OHV	1973-78	30
			410 (6.7L) OHV	1966-67	30
			427 (7.0L) OHV	1968	30
			428 (7.0L) OHV	1975-78	30
			428 (7.0L) OHV	1966-70	30
MO1450M STD 010	FORD	L6	240 (3.9L) OHV	1965-74	18
			300 (4.9L) OHV	1965-96	22
MO1451M STD 010	CHRYSLER	V8	273 (4.5L) OHV	1964-69	24
			277 (4.6L) OHV	1956-57	24
			301 (4.9L) OHV	1957	24
			303 (5.0L) OHV	1956	24
			313 (5.1L) OHV	1957-58	24
			318 (5.2L) OHV	1957-73	24
			318 (5.2L) OHV	1974-03	24
			318 (5.2L) OHV	1993-98	24
			326 (5.3L) OHV	1959	24
			340 (5.7L) OHV	1968-73	26
			360 (5.9L) OHV	1971-03	29
			360 (5.9L) OHV	1974-01	29
			360 (5.9L) OHV	1971-73	29
			360 (5.9L) Chrysler OHV	1974-2001	29
			360 (5.9L) OHV	1971-78	29
360 (5.9L) OHV	1979-99	29			

NÚMERO BUJE DE ÁRBOL

MORESA!

No. de Parte	Armadora	CIL.	MOTOR / APLICACIÓN	AÑO	LINEA
Part Number	Manufacturer	CYL.	ENGINE / APPLICATION	YEAR	LINE
MO1459M STD	FORD	L4	1.3 L, (1.3L) HSC	1998-02	1
			1.4 L, (1.4L) HSC	1998-04	1
			1.6 L (1.6L) HSC, Zetec Rocam ZL	1998-04	1
MO1460M STD	FORD	L4	122 (2.0L) SOHC 8 valve	1983-88	7
			140 (2.3L) SOHC 8 valve	1974-97	7
			140 (2.3L) Turbo SOHC 8 valve	1979-90	7
			153 (2.5L) SOHC 8 valve	1998-01	7
	MAZDA	L4	140 Ford SOHC 8 valve	1994-97	5
153 Ford SOHC 8 valve	1998-01	5			
MO1461M STD	GM	L4	151 (2.5L) Pontiac OHV	1977-84	11
			151 (2.5L) Pontiac OHV Vin "R", "2"	1985-92	11
			151 (2.5L) Pontiac OHV Vin "A", "E"	1985-93	11
	VAM	L4	151 (2.5L) Pontiac Engine	1980-83	2
MO1462M STD	GM	V6	181 (3.0L) Buick OHV	1982-88	14
			231 (3.8L) Buick Turbo OHV	1978-89	14
			196 (3.2L) Buick OHV	1964-77	16
			252 (4.1L) Buick OHV	1980-84	16
			231 (3.8L) Buick OHV, Vin "C", "L", Series I	1988-95	21
			231 (3.8L) Buick OHV, Vin "K", Series II	1995-04	21
			231 (3.8L) Buick Supercharged OHV, Vin "1"	1991-04	21
			231 (3.8L) Buick OHV, Exc. 3800 Series I and II	1975-88	21
			231 (3.8L) Buick OHV, Vin "C", "L", Series I	1988-95	21
			231 (3.8L) Buick OHV Type K 3800 Series II	1995-05	21
			231 (3.8L) Buick Supercharged OHV, Vin "1"	1991-05	21
			231 (3.8L) Type 1 Supercharged 3800 Series II	1996-99	21
MO1463M STD	GM	V6	200 (3.3L) Chevrolet OHV	1978-79	17
			229 (3.8L) Chevrolet OHV (K)	1980-84	17
			262 (4.3L) Chevrolet exc. High Output, OHV	1985-06	25
			262 (4.3L) Chevrolet High Output OHV Vin "B" LU4	1990-91	25
			262 (4.3L) Chevrolet Turbo OHV Vin "Z" LB4	1991-93	25

MORESA

NÚMERO BUJE DE ÁRBOL

No. de Parte	Armadora	CIL.	MOTOR / APLICACIÓN	AÑO	LINEA
Part Number	Manufacturer	CYL.	ENGINE / APPLICATION	YEAR	LINE
MO1466M STD	GM	V8	260 (4.3L) Oldsmobile OHV	1975-82	27
			350 (5.7L) Oldsmobile OHV	1968-80	27
			307 (5.0L) Oldsmobile OHV	1980-90	34
			403 (6.6L) Oldsmobile OHV	1977-79	39
MO1473M STD 010	CHRYSLER	L6	170 (2.8L) OHV	1960-71	13
			198 (3.2L) OHV	1969-76	13
			225 (3.7L) OHV	1960-87	20
MO1484M STD 010	CHRYSLER	V8	360 (5.9L) OHV	1971-03	29
			360 (5.9L) OHV	1974-01	29
			360 (5.9L) OHV	1971-73	29
			360 (5.9L) Chrysler OHV	1974-2001	29
			360 (5.9L) OHV	1971-78	29
			360 (5.9L) OHV	1979-99	29
MO1485M STD	GM	L4	112 (1.8L) Chevrolet OHV	1982	6
			121 (2.0L) OHV LL8 Type 1	1987-89	6
			121 (2.0L) OHV Types B,P	1983-86	6
			121 (2.0L) OHV Type Y	1983-84	6
			122 (2.0L) Chevrolet (Cosworth) DOHC 16 valve	1975-77	6
			140 (2.3L) Chevrolet SOHC 8 valve	1971-77	6
			153 (2.5L) Chevrolet OHV	1962-70	6
			121 (2.0L) OHV LL8	1987-89	7
			134 (2.2L) OHV Types G,4	1990-97	7
MO1487M STD	CHRYSLER	L4	135 (2.2L) SOHC 8 valve	1981-94	6
			135 (2.2L) DOHC 8 valve	1988-91	6
			135 (2.2L) Turbo SOHC 8 valve	1984-90	6
			135 (2.2L) Turbo DOHC 16 valve	1988-93	6
			153 (2.5L) SOHC 8 valve	1986-95	9
			153 (2.5L) Turbo SOHC 8 valve	1989-92	9

NÚMERO BUJE DE ÁRBOL

MORESA!

No. de Parte	Armadora	CIL.	MOTOR / APLICACIÓN	AÑO	LINEA
Part Number	Manufacturer	CYL.	ENGINE / APPLICATION	YEAR	LINE
MO1492M STD 010	GM	V6	173 (2.8L) Chevrolet OHV, First Design	1980-85	12
			173 (2.8L) Chevrolet OHV, Second Design	1985-93	12
			173 (2.8L) Chevrolet LPG	1987-89	13
			173 (2.8L) Chevrolet Meth	1987-89	13
			191 (3.1L) Types D,M,T,W,V6	1988-05	13
			191 (3.1L) Chevrolet Turbo OHV	1989-90	13
			207 (3.4L) OHV Type S	1993-03	13
			207 (3.4L) DOHC 24 valve Type X	1991-97	13
MO1493M STD	FORD	V6	232 (3.8L) OHV	1982-04	17
			232 (3.8L) Supercharged OHV	1989-95	17
			238 (3.9L) OHV	2004	17
MO1494M STD	FORD	L4	140 (2.3L) HSC OHV	1984-85	9
			140 (2.3L) HSC OHV	1984-94	9
			153 (2.5L) HSC OHV	1986-91	9
MO1495M STD	FORD	V6	171 (2.8L) OHV	1974-79	13
			171 (2.8L) OHV	1983-86	13
			171 (2.8L) OHV	1983-86	13
MO1557M STD 010	GM	L6	194 (3.2L) Chevrolet OHV	1962-67	15
			215 (3.5L) Pontiac OHV	1964-65	15
			230 (3.8L) Chevrolet OHV	1962-70	15
			230 (3.8L) Pontiac SOHC 12 valve	1966-67	15
			250 (4.1L) Pontiac SOHC 12 valve	1968-69	23
			250 (4.1L) Chevrolet OHV	1966-84	23
			250 (4.1L) Chevrolet OHV	1994-98	23
			292 (4.8L) Chevrolet OHV Vin "T"	1963-90	26
MO1592M STD	NISSAN	L4	A12 (1.2L)	1970-82	1
			A12A (1.2L)	1978-81	1
			A13 (1.3L)	1976-81	1
			A13S (1.3L)	1976-81	1
			A14 (1.4L)	1974-84	1
			A15 (1.5L)	1980-91	1

MORESA

NÚMERO BUJE DE ÁRBOL

No. de Parte	Armadora	CIL.	MOTOR / APLICACIÓN	AÑO	LINEA
Part Number	Manufacturer	CYL.	ENGINE / APPLICATION	YEAR	LINE
MO1713M STD	VW	4	1200 (1.2L) 112,113,126	1966-04	1
			1300 (1.3L)	1966-04	1
			1500 (1.5L) 311,341	1966-04	1
			1600 (1.6L) 122,126,211,311	1966-04	1
MO1726M STD	AUDI	L4	1500 (1.5L)	1972-	1
			1588 cc (1.6L)	1972-	1
			1600 (1.6L) ABB,ABM,ADA,ADP- AEH,DT,JU,PP,RN	1985 -	1
MO1731M STD	FORD	L4	1.3 L, (1.3L) HSC	1998-02	1
			1.4 L, (1.4L) HSC	1998-04	1
			1.6 L (1.6L) HSC, Zetec Rocam ZL	1998-04	1
MO1755M STD	GM	V6	173 (2.8L) Chevrolet LPG	1987-89	13
			173 (2.8L) Chevrolet Meth	1987-89	13
			191 (3.1L) Types D,M,T,W,V6	1988-05	13
			191 (3.1L) Chevrolet Turbo OHV	1989-90	13
			207 (3.4L) OHV Type S	1993-03	13
			207 (3.4L) DOHC 24 valve Type X	1991-97	13
			181 (3.0L) Buick OHV	1982-88	14
			231 (3.8L) Buick Turbo OHV	1978-89	14
			204 (3.3L) Buick OHV	1988-93	18
			231 (3.8L) Buick OHV, Vin "C", "L", Series I	1988-95	21
			231 (3.8L) Buick OHV, Vin "K", Series II	1995-04	21
			231 (3.8L) Buick Supercharged OHV, Vin "1"	1991-04	21
			231 (3.8L) Buick OHV, Exc. 3800 Series I and II	1975-88	21
			231 (3.8L) Buick OHV, Vin "C", "L", Series I	1988-95	21
			231 (3.8L) Buick OHV Type K 3800 Series II	1995-05	21
231 (3.8L) Buick Supercharged OHV, Vin "1"	1991-05	21			
231 (3.8L) Type 1 Supercharged 3800 Series II	1996-99	21			
MO1757M STD 010	GM	V8	252 (4.1L) Cadillac OHV	1982-88	24
			273 (4.5L) Cadillac OHV	1988-92	24
			300 (4.9L) Cadillac OHV	1991-95	24

NÚMERO BUJE DE ÁRBOL

MORESA!

No. de Parte	Armadora	CIL.	MOTOR / APLICACIÓN	AÑO	LINEA
Part Number	Manufacturer	CYL.	ENGINE / APPLICATION	YEAR	LINE
MO1776M STD	NISSAN	L4	E15, E15S (1.5L) SOHC 8 valve	1981-91	3
			E15T (1.5L) Turbo SOHC 8 valve	1983-84	3
			E16 (1.6L) SOHC 8 valve	1983-86	3
			E16I, E16S (1.6L) SOHC 8 valve	1986-88	3
MO1781M STD	FORD	L6	300 (4.9L) OHV	1965-96	22
MO1782M STD	GM	V6	181 (3.0L) Buick OHV	1982-88	14
			231 (3.8L) Buick Turbo OHV	1978-89	14
			196 (3.2L) Buick OHV	1964-77	16
			252 (4.1L) Buick OHV	1980-84	16
			231 (3.8L) Buick OHV, Vin "C", "L", Series I	1988-95	21
			231 (3.8L) Buick OHV, Vin "K", Series II	1995-04	21
			231 (3.8L) Buick Supercharged OHV, Vin "1"	1991-04	21
			231 (3.8L) Buick OHV, Exc. 3800 Series I and II	1975-88	21
			231 (3.8L) Buick OHV, Vin "C", "L", Series I	1988-95	21
			231 (3.8L) Buick OHV Type K 3800 Series II	1995-05	21
			231 (3.8L) Buick Supercharged OHV, Vin "1"	1991-05	21
231 (3.8L) Type 1 Supercharged 3800 Series II	1996-99	21			
MO1790M STD	CHRYSLER	V6	239 (3.9L) OHV Dodge Truck V6 Engine	1987-03	23
MO1792M STD	CHRYSLER	L4	135 (2.2L) SOHC 8 valve	1981-94	6
			135 (2.2L) DOHC 8 valve	1988-91	6
			135 (2.2L) Turbo SOHC 8 valve	1984-90	6
			135 (2.2L) Turbo DOHC 16 valve	1988-93	6
			153 (2.5L) SOHC 8 valve	1986-95	9
153 (2.5L) Turbo SOHC 8 valve	1989-92	9			
MO1793M STD	FORD	V6	171 (2.8L) OHV	1974-79	13
			171 (2.8L) OHV	1983-86	13
			171 (2.8L) OHV	1983-86	13

MORESA

NÚMERO BUJE DE ÁRBOL

No. de Parte	Armadora	CIL.	MOTOR / APLICACIÓN	AÑO	LINEA
Part Number	Manufacturer	CYL.	ENGINE / APPLICATION	YEAR	LINE
MO1805M STD	CHRYSLER	L4	122 (2.0L) G52B Mits. SOHC 8 valve	1974-82	5
			156 (2.6L) G54B Mits. SOHC 8 valve, Type F	1978-87	5
			156 (2.6L) G54B Mits. SOHC 8 valve, Type W	1979-90	5
			156 (2.6L) G54B Mits. Turbo SOHC 8 valve	1984-90	5
	MITSUBISHI	L4	4G54 (2.6L)	1983-89	5
			G54B, 4G54 (2.6L) SOHC 12 valve	1983-89	5
			G54B (2.6L) Turbo SOHC 12 valve	1983-89	5
MO1807M STD	FORD	V6	232 (3.8L) OHV	1982-04	17
			232 (3.8L) Supercharged OHV	1989-95	17
			238 (3.9L) OHV	2004	17
			256 (4.2L) OHV	1997-06	21
MO1809M STD	CHRYSLER	V6	201 (3.3L) OHV	1990-06	16
			231 (3.8L) OHV	1991-06	16
MO1810M STD	CHRYSLER	L4	98 4G61 (1.6L) Mits. DOHC 16 valve	1990	3
			98 4G61T (1.6L) Mits. Turbo DOHC 16 valve	1989	3
			98 G32BT (1.6L) Mits. Turbo SOHC 8 valve	1971-84	3
			98 G32B (1.6L) Mits. SOHC 8 valve, Type K & Z	1971-84	3
			107 4G37 (1.8L) Mits. SOHC 8 valve	1989-92	3
			122 4G63 (2.0L) Mits. SOHC 8 valve	1983-92	3
			122 4G63 (2.0L) Mits. DOHC 16 valve	1989-94	3
			122 4G63T (2.0L) Mits. Turbo DOHC 16 valve	1989-94	3
			144 4G64 (2.4L) Mits. SOHC 8 valve	1989-94	3
			144 4G64 (2.4L) Mits. SOHC 8 valve	1993-94	3
	MITSUBISHI	L4	4G63 (2.0L) SOHC 8 valve	1989-92	4
			4G63 (2.0L) DOHC 16 valve	1989-94	4
			4G63T (2.0L) Turbo DOHC 16 valve	1989-94	4
			G64B, 4G64 (2.4L)	1985-00	4
			G64B (2.4L) SOHC 12 valve	1985-88	4
			4G64 (2.4L) SOHC 8 valve	1989-96	4
			4G64 (2.4L) SOHC 16 valve	1993-05	4
4G64 (2.4L) DOHC 16 valve	1994	4			

NÚMERO BUJE DE ÁRBOL

MORESA!

No. de Parte	Armadora	CIL.	MOTOR / APLICACIÓN	AÑO	LINEA
Part Number	Manufacturer	CYL.	ENGINE / APPLICATION	YEAR	LINE
MO1824M STD	FORD	V6	232 (3.8L) OHV	1982-04	17
			232 (3.8L) Supercharged OHV	1989-95	17
			238 (3.9L) OHV	2004	17
			256 (4.2L) OHV	1997-06	21
MO1828M STD	GM	V6	207 (3.4L) OHV Type S	1993-03	19
			207 (3.4L) DOHC 24 valve Type X	1991-97	19
MO1842M STD	FORD	L4	122 (2.0L) SOHC 8 valve	1983-88	7
			140 (2.3L) SOHC 8 valve	1974-97	7
			140 (2.3L) Turbo SOHC 8 valve	1979-90	7
			153 (2.5L) SOHC 8 valve	1998-01	7
	MAZDA	L4	140 Ford SOHC 8 valve	1994-97	5
			153 Ford SOHC 8 valve	1998-01	5
MO1843M STD	FORD	V6	183 (3.0L) OHV exc. SHO eng.	1986-06	15
MO1844M STD	FORD	V6	244 (4.0L) OHV	1990-00	19
			244 (4.0L) SOHC 12 valve	1997-01	19
			244 (4.0L) Flex Fuel SOHC 12 valve	2002-03	19
MO1855M STD	GM	V6	262 (4.3L) Chevrolet exc. High Output, OHV	1985-06	25
			262 (4.3L) Chevrolet High Output OHV Vin "B" LU4	1990-91	25
			262 (4.3L) Chevrolet Turbo OHV Vin "Z" LB4	1991-93	25
MO1889M STD	GM	V6	231 (3.8L) Buick OHV, Vin "C", "L", Series I	1988-95	21
			231 (3.8L) Buick OHV, Vin "K", Series II	1995-04	21
			231 (3.8L) Buick Supercharged OHV, Vin "1"	1991-04	21
			231 (3.8L) Buick OHV, Exc. 3800 Series I and II	1975-88	21
			231 (3.8L) Buick OHV, Vin "C", "L", Series I	1988-95	21
			231 (3.8L) Buick OHV Type K 3800 Series II	1995-05	21
			231 (3.8L) Buick Supercharged OHV, Vin "1"	1991-05	21
			231 (3.8L) Type 1 Supercharged 3800 Series II	1996-99	21

MORESA

NÚMERO BUJE DE ÁRBOL

No. de Parte	Armadora	CIL.	MOTOR / APLICACIÓN	AÑO	LINEA
Part Number	Manufacturer	CYL.	ENGINE / APPLICATION	YEAR	LINE
MO1889M STD	GM	V6	231 (3.8L) Buick OHV, Vin "C", "L", Series I	1988-95	21
			231 (3.8L) Buick OHV, Vin "K", Series II	1995-04	21
			231 (3.8L) Buick Supercharged OHV, Vin "1"	1991-04	21
			231 (3.8L) Buick OHV, Exc. 3800 Series I and II	1975-88	21
			231 (3.8L) Buick OHV, Vin "C", "L", Series I	1988-95	21
			231 (3.8L) Buick OHV Type K 3800 Series II	1995-05	21
			231 (3.8L) Buick Supercharged OHV, Vin "1"	1991-05	21
			231 (3.8L) Type 1 Supercharged 3800 Series II	1996-99	21
MO1895M STD	CHRYSLER	V6	226 (3.7L) EKG SOHC 12 valve	2002-06	21
MO3204DR STD	GM	V6	231 (3.8L) Buick OHV, Vin "C", "L", Series I	1988-95	21
			231 (3.8L) Buick OHV, Vin "K", Series II	1995-04	21
			231 (3.8L) Buick Supercharged OHV, Vin "1"	1991-04	21
			231 (3.8L) Buick OHV, Exc. 3800 Series I and II	1975-88	21
			231 (3.8L) Buick OHV, Vin "C", "L", Series I	1988-95	21
			231 (3.8L) Buick OHV Type K 3800 Series II	1995-05	21
			231 (3.8L) Buick Supercharged OHV, Vin "1"	1991-05	21
			231 (3.8L) Type 1 Supercharged 3800 Series II	1996-99	21
			262 (4.3L) Chevrolet exc. High Output, OHV	1985-06	25
			262 (4.3L) Chevrolet High Output OHV Vin "B" LU4	1990-91	25
262 (4.3L) Chevrolet Turbo OHV Vin "Z" LB4	1991-93	25			
MOCHG-16 STD	GM	L4	1.8L (1.8L) Block aluminio		4
			134 (2.2L) L61 DOHC ECOTEC	2000-05	8
			134 (2.2L) L42 DOHC ECOTEC	2003	8
			2.2L (2.2L) DOHC ECOTEC 16 valve	2001-03	8
MOFG-53 STD	FORD	V6	244 (4.0L) OHV	1990-00	19
			244 (4.0L) SOHC 12 valve	1997-01	19
			244 (4.0L) Flex Fuel SOHC 12 valve	2002-03	19
MOGMG-1 STD	GM	L4	138 (2.3L) Oldsmobile SOHC 8 valve	1992-94	9
			138 (2.3L) Oldsmobile DOHC 16 valve	1987-96	9
			146 (2.4L) DOHC Oldsmobile, LD9,16 valve	1996-02	10

MORESA

NÚMERO ARANDELAS

No. de Parte	Armadora	CIL.	MOTOR / APLICACIÓN	AÑO	LINEA
Part Number	Manufacturer	CYL.	ENGINE / APPLICATION	YEAR	LINE
AM105 STD	NISSAN	L4	E1 (1.2L)	1961-66	2
			J (1.3L)	1965-69	2
			J13 (1.3L)	1969-75	2
			J15 (1.4L)	1970-79	2
			J16 (1.6L)	1972-85	2
			J18 (1.8L)	1981-93	7
AM142 STD	RENAULT	L4	688/689/C1C (1.0L)	1963-66	1
			688/12/10, 688688.02, 688.01, 688.02/06/10/11, 688.09 (1.1L)	1965-66	1
			CIE 715 (1.1L)	1964-69	1
			CIE 715 (1.1L)	1964-69	1
			CIE,750/G750 (1.1L)	1964-69	1
			810/25/26/29/03 (1.3L)	1969-79	1
			C1J,C2J,C3J,847 (1.4L)		1
			847 700/701,C1J (1.4L)		1
			CIJ 760/764/782 (1.4L) Turbocharged		1
			CIJ,C2J,C3J (1.3L)		1
840-25 (1.3L)		1			
AM164 STD	RENAULT	L4	688/689/C1C (1.0L)	1963-66	1
			688/12/10, 688688.02, 688.01, 688.02/06/10/11, 688.09 (1.1L)	1965-66	1
			CIE 715 (1.1L)	1964-69	1
			CIE 715 (1.1L)	1964-69	1
			CIE,750/G750 (1.1L)	1964-69	1
			810/25/26/29/03 (1.3L)	1969-79	1
			C1J,C2J,C3J,847 (1.4L)		1
			847 700/701,C1J (1.4L)		1
			CIJ 760/764/782 (1.4L) Turbocharged		1
			CIJ,C2J,C3J (1.3L)		1
			840-25 (1.3L)		1
			697.01 (1.5L)	1966-70	2
			807 03/04/05/06 (1.6L)	1969-85	2
			807 10/11 (1.6L)		2
			807 12/13/20 (1.6L)		2
			821 (9CV) (1.6L)		2
			807 A 7 27 (1.6L)		2
			843/841 (1.6L)	1973-77	2
			841/841 (1.6L) (A2M)		2
841-99 (1.6L) A1M		2			

NÚMERO ARANDELAS

MORESA!

No. de Parte	Armadora	CIL.	MOTOR / APLICACIÓN	AÑO	LINEA
Part Number	Manufacturer	CYL.	ENGINE / APPLICATION	YEAR	LINE
AM231 STD	FORD	L4	110 (1.8L) Mazda VB SOHC 8 valve	1972-78	3
			121 (2.0L) Mazda MB SOHC 8 valve	1979-82	3
	MAZDA	L4	UB (1.5L)	1970-73	2
			NA (1.6L) SOHC 8 valve	1970-77	2
			VC (1.8L)	1973-86	2
			VB (1.8L) SOHC 8 valve	1968-78	3
MA (2.0L) SOHC 8 valve	1977-89	3			
AM303 STD	TOYOTA	L4	2TC (1.6L) OHV	1971-79	2
			12T (1.6L)	1976-84	2
			3TC (1.8L) OHV, 3T-G	1980-82	2
			13T (1.8L)	1977-82	2
			13T (1.8L)	1977-82	2
			4T-G (1.8L)	1982-84	2
			2SELC (2.0L) SOHC 8 valve	1982-86	4
			3SGELC (2.0L) DOHC 16 valve	1987-91	4
			3SFE (2.0L) DOHC 16 valve	1987-00	4
			3YEC (2.0L) OHV	1982-85	4
3SGTE (2.0L) Turbo DOHC 16 valve	1986-95	4			
5SFE (2.2L) DOHC 16 valve	1985-01	4			
AM326 STD	TOYOTA	L4	8RC (1.9L) SOHC	1969-71	3
			18RC (2.0L) SOHC	1972-74	3
			20R (2.2L) SOHC 8 valve	1974-82	5
			22R (2.4L) SOHC 8 valve	1980-90	5
			22RE (2.4L) SOHC 8 valve	1989-95	5
			22REC (2.4L) SOHC 8 valve	1983-88	5
			22RTEC (2.4L) Turbo SOHC 8 valve	1985-88	5
AM327 STD	HONDA	L4	EB1 (1.2L) SOHC 8 valve	1973	1
			EB2,EB3 (1.2L) SOHC 8 valve	1974-79	1
			EE (1.2L) SOHC 8 valve	1975-79	1
			EJ1 (1.3L) SOHC 8 valve	1980-83	1
			EN (1.3L) SOHC 8 valve	1979-83	1
			EV2 (1.3L) SOHC 8 valve	1983-87	2
			EM1 (1.5L) SOHC 8 valve	1979-83	2
			EW1,EW3,EW4 (1.5L) SOHC 12 valve	1984-86	2
			ED1,ED2,ED3,ED4 (1.5L) SOHC 8 valve	1974-78	2
			EF1 (1.6L) SOHC 8 valve	1976-86	2
EK,EK1 (1.8L) SOHC 8 valve	1978-83	2			

No. de Parte	Armadora	CIL.	MOTOR / APLICACIÓN	AÑO	LINEA
Part Number	Manufacturer	CYL.	ENGINE / APPLICATION	YEAR	LINE
AM370 STD	MAZDA	L4	TC (1.3L) SOHC	1978	1
			UC (1.4L) SOHC	1979-80	1
			E5 (1.5L) SOHC	1981-85	1
AM401 STD	TOYOTA	L4	3AC (1.5L) SOHC 8 valve	1979-90	1
			1AC (1.5L) SOHC 8 valve	1978-80	1
			5A (1.5L)	1987-	1
			4ALC (1.6L) SOHC 8 valve	1983-88	1
			4AC (1.6L) SOHC 8 valve	1983-87	1
			4AF (1.6L) DOHC 16 valve	1988-89	1
			4AFE (1.6L) DOHC 16 valve	1989-97	1
			4AGEC (1.6L) DOHC 16 valve	1985-87	1
			4AGELC (1.6L) DOHC 16 valve	1985-89	1
			4AGZE (1.6L) Supercharged DOHC 16 valve	1987-89	1
			4AGE (1.6L) DOHC 16 valve	1988-91	1
AM451 STD	GM	L4	111 (1.8L) Isuzu SOHC 8 valve	1972-82	5
			119 (1.9L) Isuzu SOHC 8 valve LR1	1982-85	5
	ISUZU	L4	G180 (1.8L) SOHC 8 valve	1969-87	1
			4FB1, 4FB1-T (1.8L)	1979-86	1
			4ZC1 (2.0L) SOHC Turbo	1985-89	2
			4ZD1 (2.2L) SOHC 8 valve	1986-95	2
			G200 (2.0L)	1988-89	3
			G200 (2.0L) SOHC 8 valve	1988-89	3
AM458 STD	CHRYSLER	V6	153 (2.5L) 6G73 Mits. EEB SOHC 24 valve	1995-00	11
			181 (3.0L) 6G72 Mits. SOHC 12 valve	1987-00	15
			181 (3.0L) 6G72 Mits. DOHC 24 valve	1991-96	15
			181 (3.0L) 6G72 Mits. Turbo DOHC 24 valve	1991-96	15
			181 (3.0L) 6G72 DOHC (Nat. Asp.)	1991-99	15
	MITSUBISHI	V6	6G72 (3.0L)	1986-92	6
			6G72 (3.0L) SOHC 12 valve	1988-99	6
			6G72 (3.0L) SOHC 24 valve	1994-05	6
			6G72 (3.0L) DOHC 24 valve	1991-99	6
6G72T (3.0L) Turbo DOHC 24 valve	1991-99	6			

NÚMERO ARANDELAS

MORESA!

No. de Parte	Armadora	CIL.	MOTOR / APLICACIÓN	AÑO	LINEA
Part Number	Manufacturer	CYL.	ENGINE / APPLICATION	YEAR	LINE
AM463 STD	TOYOTA	L4	20R (2.2L) SOHC 8 valve	1974-82	5
			22R (2.4L) SOHC 8 valve	1980-90	5
			22RE (2.4L) SOHC 8 valve	1989-95	5
			22REC (2.4L) SOHC 8 valve	1983-88	5
			22RTEC (2.4L) Turbo SOHC 8 valve	1985-88	5
AM7001 STD	NISSAN	L4	K4M (1.6L)	1999-08	6
	RENAULT	L4	K4M (1.6L)	1999-08	3
AM7002 STD	FORD	L4	1.3 L, (1.3L) HSC	1998-02	1
			1.4 L, (1.4L) HSC	1998-04	1
			1.6 L (1.6L) HSC, Zetec Rocam ZL	1998-04	1

MORESA

INTERCAMBIOS CLEMEX A MORESA

COJINETES BIELA

CLEMEX	MORESA
CB 1005 P	4B1005
CB 1017 P	4B1017
CB 1110 P	4B1110
CB 1120 P	4B1120
CB 1202 P	4B1202
CB 1214 P	6B1214
CB 1216 P	4B1216
CB 1218 P	4B1218
CB 1220 P	4B1220
CB 1220 P	4B1220
CB 1222 P	4B1222
CB 1223 P	4B1223
CB 1227 P	6B1227
CB 1228 P	6B1228
CB 1238 A	6B1238
CB 1250 P	4B1250
CB 1269 P	4B1269
CB 1270 P	4B1270
CB 1278 P	4B1278
CB 1279 P	4B1279
CB 1283 P	6B1283
CB 1326 P	4B1326
CB 1358 P	6B1358
CB 1361 P	4B1361
CB 1362 P	4B1362
CB 1377 P CB 1099 P CB 1371 P CB 1654 P	4B1377
CB 1380 P	4B1380
CB 1383 P	4B1383
CB 1385 P	6B1385
CB 1387 P	6B1387
CB 1388 P	4B1388
CB 1401 P	4B1401
CB 1410 P	6B1410
CB 1411 P	6B1411
CB 1426 P	4B1426
CB 1426 P	4B1426
CB 1426 P	5B1426
CB 1442 P	8B1442
CB 1442 P	10B1442
CB 1443 P	6B1443
CB 1451 P	4B1451

CLEMEX	MORESA
CB 1589 P	4B1589
CB 1590 P	4B1590
CB 1591 P	6B1591
CB 1629 P	4B1629
CB 1635 P	4B1635
CB 1647 P	4B1647
CB 1667 P	6B1667
CB 1670 P	6B1670
CB 1784 P	8B1784
CB 1827 P	4B1827
CB 4121 P	4B4121
CB 416 P	6B416
CB 4565 P	4B4565
CB 461 P	8B461
CB 481 P	8B481
CB 527 P	8B527
CB 583 P	4B583
CB 583 P	6B583
CB 606 P	6B606
CB 610 P	4B610
CB 610 P	6B610
CB 610 P	8B610
CB 6155 P	6B6155
CB 634 P	8B634
CB 663 P	6B663
CB 663 P	8B663
CB 684 P	8B684
CB 699 P	6B699
CB 7001 P	4B7001
CB 7002 P	4B7002
CB 722 P	4B722
CB 723 P	6B723
CB 743 P	8B743
CB 745 P	4B745
CB 745 P	6B745
CB 745 P	8B745
CB 760 P	8B760
CB 780 P	4B780
CB 818 P	8B818
CB 831 P	8B831
CB 927 P	8B927
CB 960 P	4B960
CB 960 P	6B960
CB 960 P	8B960

CLEMEX	MORESA
CB 966 P	4B966
CB 966 P	6B966
CB 967 P	4B967
CB 980 P	4B980
CB 984 P	4B984
CB-1818 P	6B1818
CB-1824 AL	6B1824
CBX832	4BX832

INTERCAMBIOS CLEMEX A MORESA

MORESA

COJINETES BANCADA

CLEMEX	MORESA
MS 2199 P	5C2199
MS 1038 P	5C1038
MS 1039 P	5C1039
MS 1051 P	5C1051
MS 1053 P	4C1053
MS 1054 P	5C1054
MS 1055 P	3C1055
MS 1102 P	5C1102
MS 1106 P	7C1106
MS 1107 P	5C1107
MS 1117 P	5C1117
MS 1140 P MS 910M	5C1140
MS 1157 P	5C1157
MS 1183 P	5C1183
MS 1266 P	5C1266
MS 1298 P	5C1298
MS 1329 P	3C1329
MS 1344 P	5C1344
MS 1381 P	5C1381
MS 1389 P	7C1389
MS 1416 P	4C1416
MS 1417 P	4C1417
MS 1419 P	4C1419
MS 1424 P	5C1424
MS 1427 AL	5C1427
MS 1428 P	5C1428
MS 1431 P	5C1431
MS 1432 P	5C1432
MS 1454 P	4C1454
MS 1456 P	5C1456
MS 1494 P	4C1494
MS 1533 P	5C1533
MS 1545 P	5C1545
MS 1559 P	5C1559
MS 1560 P	5C1560
MS 1561 P	4C1561
MS 1568 P	5C1568
MS 1570 P	5C1570
MS 1590 P	5C1590
MS 1595 P	5C1595
MS 1629 P	5C1629
MS 1638 P	5C1638
MS 1668 P	5C1668

CLEMEX	MORESA
MS 1701 P	4C1701
MS 1702 P	4C1702
MS 1703 P	5C1703
MS 1706 P	5C1706
MS 1714 P	5C1714
MS 1720 P	4C1720
MS 1733 P	5C1733
MS 1743 P	5C1743
MS 1749 P	5C1749
MS 1775 P	5C1775
MS 1803 P	5C1803
MS 1812 P	4C1812
MS 1822 P	4C1822
MS 1945 P	5C1945
MS 1946 P	4C1946
MS 1947 P	7C1947
MS 1948 P	5C1948
MS 1949 P	5C1949
MS 1950 P	5C1950
MS 1951 P	4C1951
MS 1983 P	4C1983
MS 2006 P	4C2006
MS 2007 P	5C2007
MS 2010 P	4C2010
MS 2015 P	5C2015
MS 2022 P	4C2022
MS 2028 P	5C2028
MS 2037 P	4C2037
MS 2056 P	5C2056
MS 2209 P	4C2209
MS 2226 P	5C2216
MS 2244 P	4C2244
MS 3000 P	4C3000
MS 3001 P	5C3001
MS 445 P	5C445
MS 517 P	4C517
MS 518 P	4C518
MS 540 P	5C540
MS 590 P	5C590
MS 616 P	5C616
MS 617 P	7C617
MS 685 P	5C685
MS 7003 P	5C7003
MS 7004 P	5C7004

CLEMEX	MORESA
MS 704 P	7C704
MS 7141 P	5C7141
MS 7296 P	5C7296
MS 7296 P	5C7296
MS 7297 P MS 2203 P	6C7297
MS 7313 P MS-2201 P	5C7313
MS 771 P	7C771
MS 822 P	4C822
MS 829 P	5C829
MS 876 P	5C876
MS 909 P	5C909
MS 943 P	4C943
MS 960 P	4C960
MS 963 P	5C963
MS 979 P	7C979
MS 981 P	5C981
MS-1434 AL	6C1434
MS-2229 AL	7C2229
	5C7000

INTERCAMBIOS CLEMEX A MORESA

BUJES DE ARBOL, FLECHA BALANCEADORA Y AUXILIAR

CLEMEX	MORESA
SH 1030 S	MO1461M
SH 1095 S	MO1460M
SH 1111 S	MO1414M
SH 1112 S	MO1484M
SH 1114 S	MO1790M
SH 1197 S	MO1493M
SH 1209 S	MO1726M
SH 1212 S	MO1776M
SH 1251 S	MO1494M
SH 1254 S	MO1781M
SH 1326 S	MO1487M
SH 1350 S	MO1463M
SH 1351 S	MO1855M
SH 1355 S	MO1466M
SH 1360 S	MO1421M
SH 1364 S	MO1492M
SH 1365 S	MO1485M
SH 1371 S	MO1757M
SH 1385 S	MO1462M
SH 1390 S	MO1495M
SH 1390 S	MO1793M
SH 1403 S	MO1792M
SH 1405 S	MO1809M
SH 1429 S	MO1805M
SH 1441 S	MO1844M

CLEMEX	MORESA
SH 1447 S	MO1824M
SH 1448 S	MO1755M
SH 1469 S	MO1810M
SH 1526 S	MO1807M
SH 1789 S	MO1843M
SH 1798 S	MO3204DR
SH 1817 S	MOGMG-1
SH 1977 S	MOFG-53
SH 1980S	MO1244M
SH 1997 S	MO1895M
SH 2002 S	MOCHG-16
SH 290 S	MO1235M
SH 383 S	MO1170M
SH 510 S	MO1204M
SH 567 S	MO1450M
SH 616 S	MO1404M
SH 703 S	MO1439M
SH 710 S	MO1403M
SH 711 S	MO1459M
SH 718 S	MO1557M
SH 735 S	MO1713M
SH 764 S	MO1325M
SH 767 S	MO1592M
SH 777 S	MO1443M
SH 777 S	MO1842M

CLEMEX	MORESA
SH 781 S	MO1445M
SH 874 S	MO1473M
SH 875 S	MO1451M
SH 1094 S	MO1731M
SH 1780 S	MO1828M
	MO1782M
	MO1889M

ARANDELAS DE EMPUJE

CLEMEX	MORESA
TW 105 S	AM105
TW 142 S	AM142
TW 164 S	AM164
TW 231 S	AM231
TW 303 S	AM303
TW 326 S	AM326
TW 327 S	AM327
TW 370 S	AM370
TW 401 S	AM401
TW 451 S	AM451
TW 458 S	AM458
TW 463 S	AM463

INTERCAMBIOS FEDERAL MOGUL A MORESA

MORESA!

COJINETES BIELA

FEDERAL MOGUL	MORESA
4-4165RA	4B7001
10-1985A	10B1442
3-1140RA	4B1401
4 1540	4B1388
4 3570CPB	4B1377
4 4210CP	4B1451
4 4790P	4B1647
4 3665AP	4B1216
4 a 2020CP	4B745
4-1025RA	4B1361
4-1035CPA	4B1383
4-1130RA	4B1250
4-1400CP	4B1380
4-2380CP	4B583
4-2500RAA	4B610
4-2685CP, 4-3310RAA	4B960
4281M	8B684
4-2930CP	4B780
4-2950RA	4B722
4-2950RAA	4B1005
4-3445CP	4B984
4-3485CP	4B1120
4-3800RA	4B1269
4-3890CP	4B1270
4-3910RA	4B1279
4-3960CPA	4B1218
4-3975RA	4B1362
4-3995RA	4B1278
4-4135RA	4B4121
4-4245CP	4B967
4-4460P	4B1589
4-4465P	4B1426
4-4465P	4B1426
4-4565P	4B4565
4-4615P	4B1635
4-4805P	4B1629
4-60475RA	4B1202
4-66675CP	4B1220
4-66675RA	4B1220
4-66780CP	4B1326
4-66780CP	4B1590
4-67230CP	4B966
4-67320CP	4B980

FEDERAL MOGUL	MORESA
4-67340CP	4B1222
4-67345CP	4B1223
4-67350RA, 4-4005	4B1110
4-67370CP	4BX832
4-68095CP	4B1017
5-4465P	5B1426
6 1020A	6B1358
6 1950CP	6B416
6 2555A	6B663
6 3570AP	6B1227
6 3755APA	6B1443
6 3755CP	6B1228
6 a 2020CP	6B745
6-1220RA	6B1385
6-1460CP	6B1387
6-1735AP	6B1411
6-1845	6B1591
6-1920CP	6B1410
6-2375RA	6B606
6-2380CP	6B583
6-2500RA	6B610
6-3055CP	6B723
6-3150CPA	6B699
6-3310CPA 6-2685CP	6B960
6-3695CP	6B1214
6-3830CP	6B1283
6-4020A	6B1238
6-4395A	6B6155
6-4500A	6B1667
6-4525P	6B1824
6-4830A	6B1670
6-4840A	6B1818
6-67230CP	6B966
8 3190AP	8B743
8 - 3230 / 2300	8B760
8 2020CP	8B745
8 2555A	8B663
8-1985A	8B1442
8-2000CPA	8B461
8-2130CP	8B481
8-2320CP	8B527
8-2500RAA	8B610

FEDERAL MOGUL	MORESA
8-2600CP	8B634
8-2685CP	8B960
8-3360CP	8B818
8-3380CP	8B831
8-3400CP	8B927

MORESA

INTERCAMBIOS FEDERAL MOGUL A MORESA

COJINETES BANCADA

FEDERAL MOGUL	MORESA
4020M	5C445
4042M	5C540
4092M	4C517
4094M	5C876
4123M	5C616
4124M	7C617
4125M	5C590
4213M	4C822
4222M	4C518
4261M	5C685
4263M	4C960
4289M	7C704
4290M	7C771
4400M	5C829
4663M	5C909
4907M	5C1039
4914M	5C981
5107M	5C981
4916M	7C979
4923M	5C963
4926M	5C1038
4948M	5C1051
4979M	5C1117
4999M	5C1266
5024M	5C1344
5027M	5C1427
5028M	5C1298
5060M	5C1424
5070M	4C1419
5071M	7C1389
5078M	5C1432
5085M	4C1454
5090M	4C1494
5103M	5C1559
5108M	5C1533
6678M	5C1533
5123M	4C1561
5130M	5C1629
6101M	4C1983
6274M	5C1140
6372M	5C1183
6573M	5C1381
6444M	5C1381
6618M	5C1945

FEDERAL MOGUL	MORESA
6622M	5C1714
6630M	5C1668
6631M	5C1775
6656M	6C1434
6665M	5C1595
6667M	5C1054
6676M	5C1568
6680M	5C1638
6689M	5C1733
5130M	5C1733
6692M	5C1803
6695M	5C1706
6704M	3C1055
6758M	7C1106
6779M	5C1107
6780M	3C1329
6782M	5C1428
6786M	5C1456
6797M	5C1560
6807M	4C943
6809M	4C1053
6819M	5C1157
6825M	4C1416
6826M	4C1417
7011M	4C1702
7047M	5C1749
7050M	4C1701
7054M	5C1703
7090M	4C1720
7103M	5C1431
7139M	5C1570
7141M	5C7141
7143M	5C1102
7144M	4C1822
7148M	5C1590
7162M	4C1812
7193M	5C3001
7199M	5C7003
7211M	7C1947
7217M	5C1948
7218M	5C1545
7234M	5C1950
7242MA	4C2037
7245M	4C2006

FEDERAL MOGUL	MORESA
7262M	4C3000
7278M	4C1946
7285M	5C1949
7288M	4C2022
7291M	5C1743
7292M	5C2007
7296M	5C7296
7296M	5C7296
7297MA	6C7297
7298MA	5C2199
7304M	7C2229
7313M	5C7313
7321M	5C2056
7328M	5C2028
7351M	4C2010
7352M	5C2216
7375M	5C2015
7382MA	4C2209
7386MA	4C2244
	4C1951
	5C7000
	5C7004

INTERCAMBIOS FEDERAL MOGUL A MORESA

MORESA!

BUJES DE ARBOL, FLECHA BALANCEADORA Y AUXILIAR

FEDERAL MOGUL	MORESA
1170M	MO1170M
1203M	MO1403M
1204M	MO1204M
1235M	MO1235M
1244M	MO1244M
1325M	MO1325M
1734M	MO1325M
1404M	MO1404M
1414M	MO1414M
1421M	MO1421M
1439M	MO1439M
1443M	MO1443M
1445M	MO1445M
1449M	MO1494M
1450M	MO1450M
1451M	MO1451M
1459M	MO1459M
1460M	MO1460M
1461M	MO1461M
1462M	MO1462M
1463M	MO1463M
1466M	MO1466M
1473M	MO1473M
1484M	MO1484M
1485M	MO1485M

FEDERAL MOGUL	MORESA
1487M	MO1487M
1492M	MO1492M
1493M	MO1493M
1495M	MO1495M
1557M	MO1557M
1592M	MO1592M
1713M	MO1713M
1726M	MO1726M
1731M	MO1731M
1755M	MO1755M
1757M	MO1757M
1776M	MO1776M
1781M	MO1781M
1782M	MO1782M
1790M	MO1790M
1792M	MO1792M
1793M	MO1793M
1838M	MO1793M
1805M	MO1805M
1807M	MO1807M
1809M	MO1809M
1810M	MO1810M
1824M	MO1824M
1886M	MO1824M
1828M	MO1828M

FEDERAL MOGUL	MORESA
1842M	MO1842M
1843M	MO1843M
1844M	MO1844M
1855M	MO1855M
1881M	MOFG-53
1889M	MO1889M
1895M	MO1895M

ARANDELAS DE EMPUJE

FEDERAL MOGUL	MORESA
1736AF	AM458
2056BF	AM105
3567AF	AM231
3571BF	AM451
3911AF	AM370
3926AF	AM401
60476BF	AM164
67277BF	AM303
67332AF	AM326
67333AF	AM463
67341AF	AM327

INTERCAMBIOS DURABOND A MORESA

BUJES DE ARBOL, FLECHA BALANCEADORA Y AUXILIAR

DURABOND	MORESA
B-11	MO1421M
B-12	MO1462M
B-12B	MO1782M
B-13	MO1755M
B-14	MO1889M
C-4	MO1757M
CH-11	MO1557M
CH-12	MO1404M
CH-16	MO1461M
CH-17	MO1463M
CH-18	MO1492M
CH-19	MO1485M
CH-21	MO1855M
CH-3	MO1170M
CH-8	MO1235M
CHG-16	MOCHG-16
DA-1	MO1592M
DA-2	MO1325M
F-18	MO1204M
F-23A	MO1450M
F-26	MO1403M
F-28	MO1459M
F-30	MO1414M
F-32	MO1439M
F-33	MO1445M
F-34	MO1443M
F-34B	MO1842M

DURABOND	MORESA
F-45	MO1493M
F-46	MO1494M
F-47	MO1495M
F-47B	MO1793M
F-48A	MO1843M
F-49	MO1781M
F-50	MO1844M
F-52	MO1824M
FG-29	MO1731M
FG-34	MO1460M
FG-51	MO1807M
FG-53	MOFG-53
GMG-1	MOGMG-1
MIG-2	MO1805M
MIG-3	MO1810M
N-7	MO1244M
O-7	MO1466M
PD-16	MO1451M
PD-21	MO1473M
PD-25	MO1484M
PD-27	MO1790M
PD-28B	MO1809M
PDG-26	MO1487M
PDG-29S	MO1792M
VW-1	MO1713M
VWG-1	MO1726M

FRECUENCIA DE DAÑOS EN COJINETES

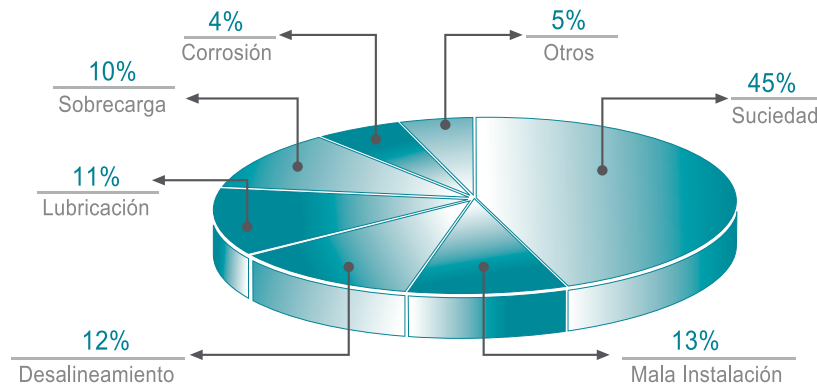

ESTAMPADO E IDENTIFICACIÓN DE PRODUCTO

Línea	Sublínea	Ejemplo	Número en pares de Bielas y Bancadas	Clave Código	Referencias de Mercado	Medida
Cojinetes (Metales)	Biela	4B481 010	4	B	481	010
	Bancada (Cigüeñal)	5C1266 020	5	C	1266	020
	Buje de árbol	MO1451M STD		MO	1451M	STD
	Aradela de ajuste	AM458 STD		AM	458	STD

Apariencia de los Cojinetes	Daño	Causas más frecuentes del daño	Recomendación / Solución
	<ul style="list-style-type: none"> Rayaduras profundas en la superficie de contacto. 	<ul style="list-style-type: none"> Suciedad en el aceite. Suciedad durante el armado del motor. Motor sin filtro de aire. Sistema de admisión deficiente. 	<ul style="list-style-type: none"> Lavar muy bien el motor antes del armado. Limpeza durante el armado del motor. No usar aceite contaminado ó usado. Realizar el cambio de aceite en los periodos recomendados por el fabricante del vehículo. Usar filtro de aceite nuevo. Usar filtro de aire nuevo. Verifique no haya grietas, fisuras, orificios, ó bien mangueras rotas en el sistema de admisión.



•Nota: En todos los casos no reutilice los cojinetes usados.

DAÑOS EN COJINETES

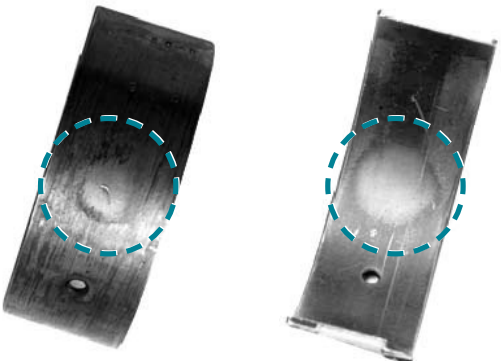

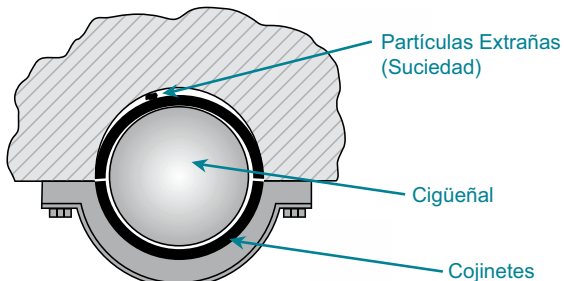
MORESA

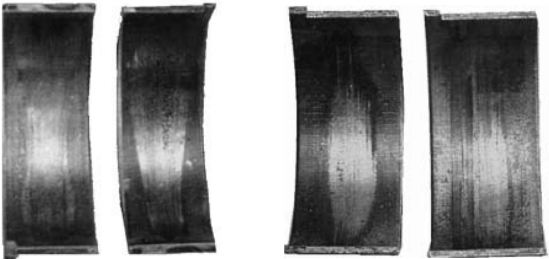
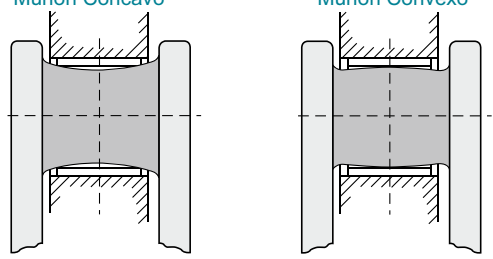
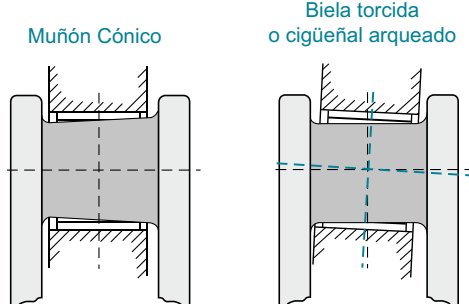
Apariencia de los Cojinetes	Daño	Causas más frecuentes del daño	Recomendación / Solución
	<ul style="list-style-type: none"> • Desgaste prematuro del cojinete. 	<ul style="list-style-type: none"> • Partículas extrañas ó suciedad entre el cojinete y alojamiento. • Suciedad durante el armado. 	<ul style="list-style-type: none"> • Lavar muy bien el motor antes del armado. • Limpieza durante el armado del motor. • Usar apriete ó torque especificado.



Apariencia de los Cojinetes	Daño	Causas más frecuentes del daño	Recomendación / Solución
 <p>Muñón Cóncavo Muñón Convexo</p>   <p>Muñón Cónico Biela torcida o cigüeñal arqueado</p> 	<ul style="list-style-type: none"> • Desgaste irregular en los cojinetes por rectificaco inadecuado. 	<ul style="list-style-type: none"> • Maquinado de cigüeñal inadecuado. • Biela torcida. • Cigüeñal arqueado. • Cigüeñal golpeado. 	<ul style="list-style-type: none"> • Revise claro de lubricación y huella de asentamiento con plastigage. • Verifique que las bielas ó el cigüeñal no esten torcidos. • Revise el alineamiento del cigüeñal con micrómetro de reloj. • Limpieza durante el armado del motor. • Usar apriete ó torque especificado.

DAÑOS EN COJINETES

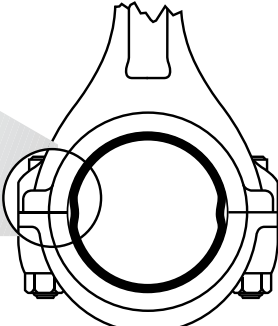
Apariencia de los Cojinetes	Daño	Causas más frecuentes del daño	Recomendación / Solución
  	<ul style="list-style-type: none"> Torque excesivo 	<ul style="list-style-type: none"> Tiraje excesivo. Torque ó apriete excesivo. Altura inadecuada de las tapas de las bielas ó cigüeñal (rebajadas). 	<ul style="list-style-type: none"> Usar apriete ó torque especificado. Nunca rebaje la altura de las tapas de las bielas ó cigüeñal. Revise claro de lubricación y huella de asentamiento con plastigage.

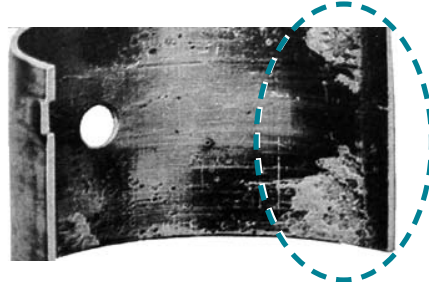

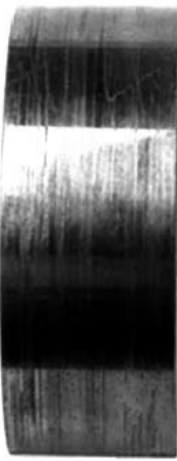

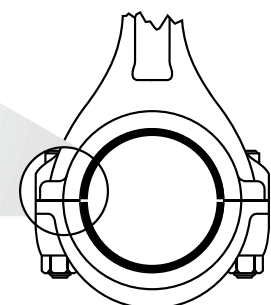
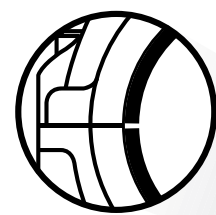
Apariencia de los Cojinetes	Daño	Causas más frecuentes del daño	Recomendación / Solución
  <p>Sin Muesca</p> <p>Respaldo Brillante (Se Giró)</p>	<ul style="list-style-type: none"> Torque insuficiente. 	<ul style="list-style-type: none"> Tiraje insuficiente. Torque ó apriete insuficiente. Suciedad entre las tapas. 	<ul style="list-style-type: none"> Usar apriete ó torque especificado. Nunca lime ó rebaje el tiraje del cojinete. Verifique las condiciones de los tornillos (elongación y condiciones de la cuerda). Limpeza durante el armado del motor (limpie adecuadamente las caras de las tapas). Revise claro de lubricación y huella de asentamiento con plastigage.



DAÑOS EN COJINETES

MORESA

Apariencia de los Cojinetes	Daño	Causas más frecuentes del daño	Recomendación / Solución
	<ul style="list-style-type: none"> Lubricación deficiente. 	<ul style="list-style-type: none"> Baja presión de aceite. Venas y orificios de lubricación semiobstruidos. Lubricación deficiente. 	<ul style="list-style-type: none"> Revise constantemente el nivel de aceite en el motor. Verificar presión de aceite. Usar bomba de aceite nueva. Precargar bomba de aceite durante el armado del motor. Lavar muy bien el motor antes del armado. Verificar que las venas y orificios de lubricación no estén tapados. Limpeza durante el armado del motor. Usar apriete ó torque especificado.

Apariencia de los Cojinetes	Daño	Causas más frecuentes del daño	Recomendación / Solución
	<ul style="list-style-type: none"> Ausencia de lubricación. 	<ul style="list-style-type: none"> Los residuos de aceite contaminado tapan las venas de lubricación. Venas y orificios de lubricación tapados. Ausencia de lubricación en el sistema. Alta temperatura en el cojinete. 	<ul style="list-style-type: none"> Realizar los cambios de aceite, en los periodos recomendados por el fabricante. No usar aceite contaminado ó usado. Verificar presión de aceite. Usar bomba de aceite nueva Precargar bomba de aceite durante el armado del motor. Lavar muy bien el motor antes del armado. Verificar que las venas y orificios de lubricación no estén tapados. Limpeza durante el armado del motor. Usar apriete ó torque especificado.

• **IMPORTANTE:** Se recomienda realizar el mantenimiento preventivo al motor de acuerdo a especificaciones del fabricante. Ya que de esta manera aseguramos larga vida a los componentes internos del motor .